



起重設備專業製造商

 www.hbjieteqizhong.com
 0312-8152843 15633223500
 河北清苑东吕工业园北区
 hbdalonglove2@163.com

HEBEI JET
LIFTING RIGGING
TOOL FACTORY

捷特起重设备制造有限公司

HSZ 型手拉葫芦 HSZ chain block

HSZ型系列手拉葫芦是一种使用广泛，携带方便的手动起重工具，可用于工业、农业、建筑业、矿业等的机器安装、货物起吊、车辆装卸，尤其适用于露天及无电源作业。

HSZ series chain blocks is a king of widely used and portable manual operating hoisting machine, it can be used in machine installation, products lifting and unloading in industry, agriculture, construction and mineral production. It is suitable to be used in the open air and no electric power.

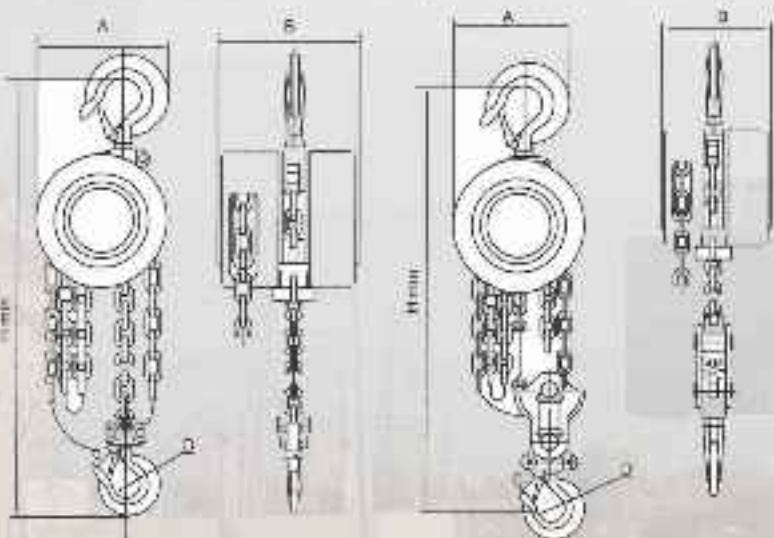

型号 Model	HSZ1/2	HSZ1	HSZ 1/2	HSZ2	HSZ3	HSZ5	HSZ10	HSZ20
起重量 Capacity (吨 t)	0.5	1	1.5	2	3	5	10	20
标准起重高度 Standard lift (米 m)	2.5	2.5	2.5	2.5	3	3	3	3
试验载荷 Running testload (吨 t)	0.75	1.5	2.25	3	4.5	7.5	12.5	25
钩间最小距离 Min distance between hooks (毫米 mm)	290	350	420	430	500	620	820	1060
满载时手拉拉力 Chain pull to lift full load (牛顿 N)	225	309	343	314	343	383	392	392
起重链行数 No. of load chain fall lines	1	1	1	2	2	2	4	8
起重链直径 Diameter of load chain (毫米 mm)	6	6	8	6	8	10	10	10
主要尺寸 Dimensions (毫米 mm)	A	120	142	178	142	178	210	358
	B	108	122	139	122	139	162	189
	C	24	28	34	34	38	48	82
	D	120	142	178	142	178	210	210
净重 Net weight (公斤 kg)	9.5	10	16	14	24	36	68	135

VD 手拉葫芦

VD chain block



- Bearing mechanism increases mechanical efficiency.
- Forged and heat treat top and bottom hooks with safety latch.
- Double pawl mechanism supporting brake system.
- Double cover to keep out rainwater and dust.
- Sure and Reliable mechanical brake.
- Highly accurate and durable gears.
- Alloy steel load chain. Variety surface treating option.

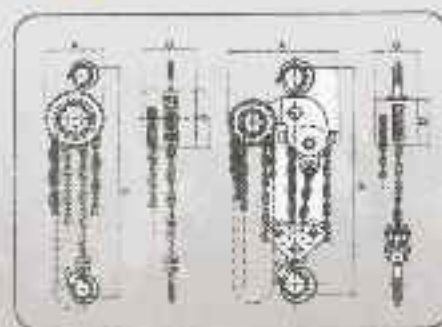

型号 Model	HS-E1	HS-E1.5	HS-E2	HS-E3	HS-E5	HS-E10
起重量 Capacity (吨 t)	1	1.5	2	3	5	10
标准起重高度 Standard lift (米 m)	2.5	2.5	3	3	3	3.5
试验载荷 Running testload (吨 t)	1.5	2.25	3	4.5	7.5	15
钩间最小距离 Min distance between hooks (毫米 mm)	352	385	385	445	615	765
满载时手拉拉力 Chain pull to lift full load (牛顿 N)	33	34	34	35	39	41
起重链行数 No. of load chain fall lines	1	1	1	1	2	4
起重链直径 Diameter of load chain (毫米 mm)	6	7.1	8	10	9	10
净重 Net weight (公斤 kg)	14.5	16.5	19.5	32	41.1	75.7
总重 Gross Weight (公斤 kg)	15	17	20.1	34	43.6	79.1

HSZ-VT 型手拉葫芦 HSZ-VT series chain block



HS-VT 型手拉葫芦具备了高性能、高安全性又充满了灵性，巧夺天工，自成一派，让您更轻松、方便的完成工作，大大减轻您的劳动强度。

特点

滑轮：国际标准滑轮比普通葫芦耐磨度增加一倍，转动更平稳，手拉力更轻。

链条：更高强度的链条；适应突发起重作业；改变普通手拉葫芦只能垂直向下拉，适用范围更大。

吊钩：高强度足料吊钩，安全系数更高；钩头处全新设计，使货物不会松脱。

极限开关：吊上吊下都有极限开关部件，防止链条超出限位安全。

部件：主要部件均采用优质合金钢，实施严格尺寸、重量检查，保证每一部件的性能充分发挥。

机身：纤细设计，新颖大方美观；符合人体工程学，机身经工作活动界面小，适应环境广。

喷漆：先进的喷漆处理工艺，室外都适用，使用再久表面都崭新如初。

锁壳：精钢压制锁壳，坚固中原轻巧。

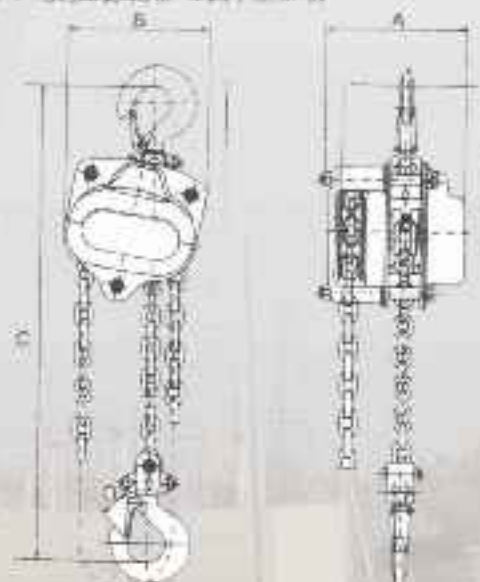

型号 Model	HS-VT	HS-VT1	HS-VT1.5	HS-VT2	HS-VT3	HS-VT5	HS-VT10	HS-VT20	HS-VT30	HS-VT50
起重量 Capacity (吨 t)	0.5	1	1.5	2	3	5	10	20	30	50
标准起重高度 Standard lift (米 m)	2.5	2.5	2.5	3	3	3	3.5	3	3	3
试验载荷 Running testload (吨 t)	0.75	1.5	2.25	3	4.5	7.5	15	25	37	62
两钩间最小距离 Min distance between hooks (毫米 mm)	285	315	340	380	475	600	700	890	980	1300
满载时手拉力 Chain pull to lift full load (牛顿 N)	25	33	34	34	35	39	41	43	45	50
起重链行数 No. of load chain fall lines	1	1	1	1	2	2	4	8	12	22
链条圆钢直径 Diameter of load chain (毫米 mm)	1.6	7.1	7.1	8	7.1	9	9	10	10	10
净重 公斤 Net weight (公斤 KG)	8.4	11	13.5	21	22	40	77	193	228	1085
装箱毛重 Gross Weight (公斤 kg)	9.4	12	14.5	22	23	41.5	85			
装箱尺寸 (长×宽×高) Packing Dimensions (L*W*H) (厘米 cm)	30×17×32	30×17×32	30×17×32	28×19×23	30×17×32	40×20×34	62×50×26	64×38×64	72×50×68	110×100×130

VL 型手扳葫芦 VL series lever block



本公司销售的 VL 系列手扳葫芦采用新设计，具有快速调整下吊钩位置的功能，造型设计新颖，款式别致，机体美观，机动性能良好，工作效率更高，一直是国内外畅销的优质名牌产品，更是您可靠的帮手。

The lever blocks of the brands Sa langan e, adopted modern design, have adjusted the sling dogs position, which have novel sculptures, unique styles, speciously looking, well capabilities, higher work efficiency, are the famous safe products and credible helper.

Model	Capacity (t)	Standard Lift (m)	Running test load (t)	Minimum distance between hooks (mm)	Hand pull force in full working (kg)	No. of columns of load chain	Load chain diameter (mm)	The length of lever handle (mm)	Net Weight (kg)	Packing measurements (L*W*H) (mm)	Gross weight per meter of web (kg)
VL-0.5	0.5	1.5	1125	290	15	1	6.3	255	9.9	37x13x17	9.95
VL-1.5	1.5	1.5	225	335	18	1	7.1	269	9.7	31x13x19	11
VL-3	3	1.5	45	475	28	1	9	308	10.3	34x19x22	19
VL-6	6	1.5	75	550	39	2	9	368	29.7	54x19x22	36

HSH-VA 手扳葫芦 HSH-VA Lever block



VA 型手扳葫芦是一种小型、多用途手动起重、牵引机械，广泛应用于电力、矿山、造船、建筑、运输、邮电等部门的设备安装、物品起吊、物件牵引、散件卸车、线路拉紧及焊接对位等场合，手扳葫芦尤其在狭小的工作场所、野外高空作业和各种不同角度的牵引更显示其优越性。

VA lever hoist is a kind of light is small, multi-purpose manual lifting, traction machine, widely used in electric power, mining, shipbuilding, construction, transportation, post and telecommunications departments such as equipment installation, lifting, part drawing, bulk, bundling, line taut and welding counterpoint, lever hoist especially in narrow workplace, field aerial work and different Angle of pull more show its superiority.

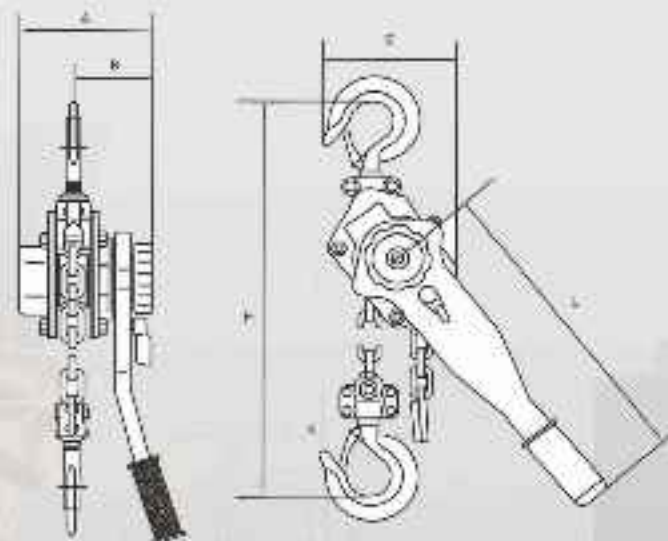

型号 Model	0.75Ton	1.5Ton	3Ton	6Ton	
起重量 Capacity 吨 t	0.75	1.5	3	6	
起重高度 Standard Lift 米 m	1.5	1.5	1.5	1.5	
试验载荷 Running testload 吨 t	9.2	18.4	36.8	73.5	
手扳力 Effort required to lift max load N	148	216	336	345	
起重链直径 Load lift diameter 毫米 mm	6.3	7.1	9	9	
净重 Net weight 公斤 kg	6.6	11.65	21.1	23.7	
主要尺寸 Dimensions 毫米 mm	A	155	170	198	198
	B	128	147	182	230
	C	310	350	470	590
	D	240	365	365	365
	G	28	36	47	49

HSZ-C 型手拉葫芦 HSZ-C series chain block



HSZ-C 型系列手拉葫芦是我公司在 HSZ 型手拉葫芦的基础上融合世界先进技术改良后的产品，除具有 HSZ 型手拉葫芦的传统特点外，更是一种手拉力小，安全系数高，外形美观，实用性更高的手拉葫芦。

HSZ-C series chain block is a newly designed product on the base of HSZ product, it combines the advanced technology in the world. Besides those traditional characteristics, HS-C series chain block is more laborsaving and beautiful, and it has higher practicability.

型号 Model	HSZ C	HSZ C1	HSZ C1	HSZ C2	HSZ C3	HSZ C5	HSZ C10	HSZ C20	
起重量 Capacity	吨 t	0.5	1	1.5	2	3	5	10	20
标准起重高度 Standard lifting height	米 m	2.5	2.5	2.5	2.5	3	3	3	3
试验载荷 Testing load	吨 t	0.75	1.5	2.25	3	4.5	7.5	12.5	25
钩头至最小距离 Min. distance between hooks	毫米 mm	255	306	336	414	486	624	790	1000
满载时手扳拉力 Pulling force to full load	牛顿 N	221	304	345	314	343	563	392	392
起重链行程 NO. of load chain links		1	1	1	2	2	2	4	8
起重链各型自然直径 Diameter of load chain	毫米 mm	6	6	8	8	8	10	10	10
主要尺寸 Dimensions		128	147	183	147	183	218	350.5	585
		111	126	141	126	141	163	163	191
		24	28	34	34	38	48	64	82
净重 Net weight	千克 kg	6	10	16	15	21	36	68	156
装箱毛重 Gross weight	千克 kg	10	13	12	17	28	42	83	194
装箱尺寸 (长×宽×高) Packing measurement(L×W×H)	厘米 cm	28x21x17	30x24x28	34x29x20	33x25x19	39x30x20	45x35x24	62x50x28	70x46x75
起重高度每增加 1 米所增加的重量 Extra weight per motor extra lift	千克 kg	1.7	1.7	2.3	2.5	3.7	5.3	9.7	18.4

G80 起重链条 G80 lifting chain

我公司链条分厂始建于1996年，于1999年正式投入生产，专业生产43级、70级、80级等各种规格链条、链条索具。2002年公司顺利通过ISO9000质量管理体系认证，产品通过国家链条质量监督检验中心检验合格，产品远销中外，深受客户的广泛欢迎。

为了进一步激烈竞争，进一步与国际市场接轨，我公司引进先进的技术设备，现有高温链条专用全自动锻焊机20台套；专用链条中频淬火设备6套；校正机7台；拉力试验机、硬度机等配套检测设备齐全。可以根据客户要求生产定做各种规格链条。

The company chain factory was established in 1996, in 1999 formally put into production, specializing in the production of level 43, level 70, level 80 etc various specifications of the chain, the chain rigging. In 2002 the company passed the ISO9000 quality system certification. The product qualified through the national chain of quality supervision and inspection center. The products are exported to all over the world, widely welcomed by customers.

In order to overcome the fierce market competition, and further with the international market, our company introduced advanced technology and set 20 sets of special chain intermediate frequency quenching machine, correction machine / sets, tensile testing machine, hardness machine and other auxiliary testing equipment. The production can be customized according to customer requirements of various specifications of the chain.



HSH 型微型手扳葫芦 HSH series Mini Lever Block

CD1、MD1型钢丝绳电动葫芦是一种小型起重设备，具有结构紧凑、重量轻、体积小、零部件通用性强、操作简便等优点。减速机采用硬齿面传动设计，寿命长、机械效率高。电机采用锥形转子制动电动机，具有上下双向安全限位装置。MD型电动葫芦具有快速和慢速两种起升速度，起吊平稳准确。

CD1、MD1型钢丝绳电动葫芦可广泛用于提升重物或安装在单梁起重机、直线、曲线的工字梁上，也可用于葫芦双梁、龙门起重机或悬臂吊上，是工矿企业、铁路、码头、仓库中常用的起重设备。

CD1、MD1 type Wire-rope electric hoist is a kind of light-small lifting equipment with advantages of light structure light weight, small volume, wide common use and convenient operation etc. It reducers with hard gear surface are applied, it will have long life and high mechanical efficiency, conic rotor brake motors are equipped which has safety limiter in both up and down directions.

MD type electric hoists have fast and slow lifting speeds which make it lift steady and accurately.

CD1、MD1 type wire-rope electric hoists can be widely used to hoist heavy objects, or installed on the straight or curve I-steel beam of single-girder cranes. They can also be used together with Electric Hoist Double-girder, gantry crane and Slewing cranes. All the above has made the electric hoists common in industrial and mine enterprises, railway, wharfs and warehouses.



规格 Size d×p mm	宽度 Width		单位长度的重 Approx Weight kg/m	极限工作载荷 Working Load t	试验载荷 Test Load kN	最大破断 负荷 Breaking Load max. kN
	最小内宽 Inside min. a	Outside max. b				
5x18	7.5	21	0.79	1.1	27	45.2
7x21	9	24.5	1.07	1.5	37	61.6
8x24	10	28	1.38	2	48	80.4
10x30	12.5	35	2.2	3.2	79	130
11x43	12.6	36.5	2.33	3.3	87	151
12x36	15	42	3.1	4.5	109	181
12.5x38	15.5	42.2	3.3	4.9	117	196
13x39	16.3	46	3.8	5	128	214
14x42	18	49	4.13	6.3	150	250
14x50	17	50	4	6.3	150	250
15x46	20	52	5.17	7	168	280
16x48	20	56	5.63	8	192	320
16x49	24.5	54.5	5.71	8	192	320
16x54	23.9	58.3	5.11	8	192	320
18x54	23	63	6.89	10	246	410
18x64	21	60	6.6	10	246	410
19x57	23.7	63.2	7.7	11.3	270	450
20x60	25	70	8.6	12.5	300	500
22x65	28	74.2	10.7	15.3	366	610
22x66	28	77	10.2	15.3	366	610
22x66	28	74	9.5	15.2	366	610
24x72	32	82	12.75	18	432	720
24x86	28	79	11.8	18	432	720
26x70	35	81	14.07	21.3	520	850
26x82	30	86	13.7	21.3	520	850
30x90	38	105	19.5	28.3	678	1130
30x108	34	98	18	29.3	678	1130
32x96	40	108	22.23	32.7	772	1286
34x126	38	109	22.7	38.3	970	1450
34x102	46.5	121.5	25.5	38.3	970	1450
36x108	40.5	123.5	31	42.7	978	1630
36x137	42	121	29	45.3	1096	1810
38x114	52	138	32	45.3	1096	1810
42x156	55.5	144.5	38.6	55.4	1332	2200

规格 Size d×p mm	宽度 Width		单位长度的重 Approx Weight kg/m	极限工作载荷 Working Load t	试验载荷 Test Load kN	最大破断 负荷 Breaking Load max. kN
	最小内宽 Inside min. a	Outside max. b				
5x18	7.5	21	0.79	1.1	27	45.2
7x21	9	24.5	1.07	1.5	37	61.6
8x24	10	28	1.38	2	48	80.4
10x30	12.5	35	2.2	3.2	79	130
11x43	12.6	36.5	2.33	3.3	87	151
12x36	15	42	3.1	4.5	109	181
12.5x38	15.5	42.2	3.3	4.9	117	196
13x39	16.3	46	3.8	5	128	214
14x42	18	49	4.13	6.3	150	250
14x50	17	50	4	6.3	150	250
15x46	20	52	5.17	7	168	280
16x48	20	56	5.63	8	192	320
16x49	24.5	54.5	5.71	8	192	320
16x54	23.9	58.3	5.11	8	192	320
18x54	23	63	6.89	10	246	410
18x64	21	60	6.6	10	246	410
19x57	23.7	63.2	7.7	11.3	270	450
20x60	25	70	8.6	12.5	300	500
22x65	28	74.2	10.7	15.3	366	610
22x66	28	77	10.2	15.3	366	610
22x66	28	74	9.5	15.2	366	610
24x72	32	82	12.75	18	432	720
24x86	28	79	11.8	18	432	720
26x70	35	81	14.07	21.3	520	850
26x82	30	86	13.7	21.3	520	850
30x90	38	105	19.5	28.3	678	1130
30x108	34	98	18	29.3	678	1130
32x96	40	108	22.23	32.7	772	1286
34x126	38	109	22.7	38.3	970	1450
34x102	46.5	121.5	25.5	38.3	970	1450
36x108	40.5	123.5	31	42.7	978	1630
36x137	42	121	29	45.3	1096	1810
38x114	52	138	32	45.3	1096	1810
42x156	55.5	144.5	38.6	55.4	1332	2200