

Edition: A07

# **IPS-HH1200 PLUS**

## **High Resolution Handheld Printer**



# **User Manual**

## Revision History

<b>Version</b>	<b>Date</b>	<b>Page</b>	<b>Revised Brief Description</b>	<b>Corresponding software version</b>
A02	2017/3/9	30、 47、 49、 50	1、 Added logo source 2、 Added plugin management 3、 Added encoder information 4、 Added photocell information	1.0.0.1745
A03	2017/5/22	18、 33、 46、 48	1、 Updated default source list and added Cut Edge feature 2、 Initial setting: added modify string feature 3、 Updated ink information 4、 Updated battery indicator	1.0.0.2086
A04	2017/7/31		1、 Add Simple Model 2、 Adjust the setting of the jet printing parameters 3、 Parameters->Option: Add Blank Line No Print 4、 Support importing JPG、 PNG、 GIF images.	
A05	2018/1/ 5			
A06	2017/2/8			

# IMPORTANT

To ensure the best printing quality, we recommend to use our specified cartridges and the corresponding accessories. Any malfunction or poor printing quality caused by improper use of inks or accessories which are not from Prima will not be guaranteed.

## Safety Precautions

High voltage inside the machine after electricity connection, Maintenance or disassembly by unqualified or unprofessional person is strictly prohibited, in order to prevent any accidents. Machine must be reliably grounded by connecting the grounding wire with the machine when install equipment, wrong grounding will result in machine failure and the machine don't work normally.

Do not expose ink directly under sunlight or high temperature (35°C above). The heat of direct sunlight or high temperature will affect ink's storage life and printing quality.

If get ink spill on the eyes or skin, please wash your eyes or skin with clean water.

Ink leakage inside printer will cause burnout damage to machine. Switch off the machine and unplug it from power outlet when ink leakage inside printer. Contact qualified service technician for test and repair.

## Warning Signs

Caution: The sign “” indicates possible damage to hardware of inkjet printer or data loss.

Attention: The sign “” indicates important notes helpful for your trouble-free operation Please read manual carefully before you use our inkjet printers.

# Introduction

Thank you for purchasing our high resolution printer. We want you to get helpful information with this machine, please read the manual to learn more about our machine by the following content:

- Important precautions for use of the machine
- Introduction of printer: Parts and components of the machine
- Setup and Installation Instructions: Instructions for Equipment Setup and Cartridge Installation.
- How to use the printer and the check work before/after use of the printer: explanations of general operation and startup/shutdown.
- Operation instructions: explanations on how to new/edit data for printing, and how to adjust printer settings.
- Care and Maintenance: Care and maintenance for printer and cartridge
- Troubleshooting: Common failures and solutions
- Appendix 1 - Terms and Definitions: Definitions for terms used in this document.

Please read this user manual carefully before using the printer to get full understanding and knowledge of importance so that you will get full play of our machine, This will also help you to have a quick reference to related sections when you have some problems during operation.

Note 1: If you cannot solve the problem encountered during operation, please contact us

Note 2: The information contained herein is subject to change without notice. The user manual will be updated and revised timely if necessary by publish new version

Note 3: Any machine failure or damage caused by user's negligence, it is no warranty.

# Contents

<b>Important Precautions for User.....</b>	<b>1</b>
<b>Installation and Setup Instructions.....</b>	<b>2</b>
1.1 PARTS LIST.....	2
1.2 BATTERY CHARGING.....	3
1.3 BATTERY INSTALLATION AND REMOVAL.....	3
1.5 POSITION WHEEL MECHANISM REPLACEMENT.....	4
1.5.1 <i>Dual wheel mechanism removal and installation</i> .....	4
1.5.2 <i>Four-wheel mechanism removal and installation</i> .....	5
<b>Inkjet Printer Introduction.....</b>	<b>6</b>
2.1 PRINTER.....	6
2.2 TECHNICAL SPECIFICATIONS.....	7
2.2.1 <i>Performance Values</i> .....	7
2.2.2 <i>Features</i> .....	8
2.2.3 <i>Ink Solutions</i> .....	8
<b>Printer Operation Instructions.....</b>	<b>9</b>
3.1 POWER ON.....	9
3.2 MAIN INTERFACE.....	9
3.3 HOW TO UPGRADE SOFTWARE(REFER TO VIDEO “HOW TO UPGRADE SOFTWARE”).....	9
3.4 HOW TO IMPORT / EXPORT DATA, IMAGES, AND SET PARAMETERS.....	10
3.4.1 <i>Data recovery/ Image / Print parameters / System parameters (Refer to video “recovery”)</i> .....	10
3.4.2 <i>Backup Data / Images / Print Parameters / System Parameters (Refer to video “Backup”)</i> .....	11
<b>Function Use Introduction.....</b>	<b>13</b>
4.1 MESSAGE MANAGEMENT-STANDARD MODE.....	13
4.1.1 <i>List Function</i> .....	13
4.1.2 <i>Toolbar</i> .....	16
4.1.3 <i>New Text Message(Refer to the video “Add New Text Message”)</i> .....	17

4.1.4 Add Date/Time (Refer to the video “Add Date/Time”)	19
4.1.5 Add Counter (Refer to the video “Add Counter”)	21
4.1.6 Add Shift Object (Refer to the video “Add Shift Object”)	23
4.1.7 Add Local Image Object(Refer to the video “Add Local Image Object”)	24
4.1.8 Add Base Image (Refer to the video “Add Base Image”)	25
4.1.9 Add Device Name Object (Refer to the video “Add Device Name Object”)	26
4.1.10 Add Scan Print Object (Refer to the video “Add Scan Print Object”)	26
4.1.12 Add Barcode (Refer to the video “Add Barcode”)	28
4.1.13 Edit Message	29
4.1.14 Copy/Paste Message	30
4.1.15 Delete Message	30
4.2MESSAGE MANAGEMENT-SIMPLE MODE	30
List Function	30
4.2.3 Toolbar	33
4.2.4 New Message (Refer to the video “Add new message in simple mode”)	34
4.2.5 Edit Message	47
4.2.6 Copy/Paste Message	47
4.2.7 Delete Message	47
4.3PRINTING MANAGEMENT	47
4.3.1 Start/Stop Printing	47
4.3.2 Printing Report Display	48
4.3.3 Printing Delay	48
4.3.4 Initial Setting	48
4.3.5 Printing Monitor	49
4.3.6 Re-print	50
4.4PRINT PARAMETER	50
4.4.1 Print Setting	50

4.4.2 Printhead Setting.....	51
4.4.3 Printing Option.....	51
4.4.4 Special Printing (Refer to the video “Continuous printing”).....	51
4.5 SYSTEM SETTING.....	52
4.5.1 System management.....	52
4.5.2 User management (Refer to the video “User management”).....	52
4.5.3 System Reset (Refer to the video “System Reset”).....	55
4.5.4 About.....	57
4.6 TOOLS.....	57
4.6.1 How to manage local images.....	57
4.6.2 How to upgrade language/ font/ typewriting.....	58
4.6.3 Permission.....	59
4.6.4 Plugin Management (Refer to the video “Plugin Management”).....	60
4.7 STATUS BAR.....	60
4.7.1 Cartridge status.....	60
4.7.2 System status.....	61
4.7.3 Encoder information (Refer to the video “Encoder Test”).....	62
4.7.4 Photocell information (Refer to the video “Photocell Test”).....	62
4.7.5 USB Status.....	62
4.7.6 Battery Indicator.....	63
4.7.7 WI-FI Status.....	63
4.7.8 Log out.....	63
4.8 INPUT METHOD INTRODUCTION.....	63
<b>Appendix 1: Terms and Definition.....</b>	<b>66</b>

---

# Important Precautions for User

Welcome to use this inkjet printer. In order to protect your personal safety and user rights, ensure correct installation and operation, and full play of the machine, it is important that you read the precautions carefully.



## Important Installation Precautions

The recommended spacing distance should be 0.5-2.5mm between internal deflector of printer and printing object.

Make sure to insert or remove ink cartridge by an angle of 15 degree so as not to damage the cartridge.

- Do not place the printer in a dusty environment and longtime use, if customer can't change, please clean the printer dust periodically .

Printer only can use original battery and charger provided by manufacturer. Do not open or place in a fire, and not allow metal contact or electrode short circuit, avoid placing in excessive heat (over 60 degrees Celsius), humid or corrosive environments.



## Important Operation Precautions

Do not poke or impact the touch screen sharply.

- The built-in photocell can't be covered, or the printer doesn't print.

Use Non-woven to wipe the nozzle plate when the print is not clear or dots are missing.

When printing position is changed, please set the printing delay to achieve best printing result.

Do not insert or remove ink cartridge while the machine is in printing process so as not to cause damage to the cartridge.

Do not use compressed air for cleaning the touch screen. High pressure of the compressed air will damage the touch screen.

Do not use compressed air for direct or indirect cleaning of the ink cartridge. High pressure of the compressed air will damage the nozzle plate.

Note: It is necessary for some cartridges to be removed from machine after operation stop. Turn off the machine and remove the cartridge from printer. Wipe the print head clean with Non- woven cloth; lock the print head with the special cap to avoid the nozzles blocking (Contact our after-sale service for more about cartridges)





# Installation and Setup Instructions

This chapter illustrates product parts list and installation of equipment and ink cartridge.

Packing Pictures	
Outer box	

## 1.1 Parts List

Please check everything with packing list to make sure all required parts in the package when you receive the products.

SN	Part Name	QTY	Photo	Note
1	Handheld printer	1		
2	USB disk	1		
3	Battery	2		
4	Charger	1		
5	Wrist Strap	1		

## 1.2 Battery Charging



Battery charging:  
Insert battery into  
charger.

Green indicator light:  
Battery not inserted or  
battery fully charged.



Battery charging finished:  
Remove battery from charger.

Red indicator light:  
Battery is on charge.

## 1.3 Battery Installation and Removal



Battery installation:  
insert the battery into  
handle and hear "click"  
indicates the battery is  
well fixed.



Battery removal: Press  
the two lock catches on  
battery, remove battery  
from printer.

## 1.4 Ink cartridge Installation (42ml)



Insert cartridge to  
printer by an angle of 15  
degree. Press vertical  
when insert right  
position, then hear  
"click", that means the  
cartridge already is  
fixed well.



Cartridge removal:  
Remove cartridge  
from printer by an  
angle of 15 degree.

## 1.5 Position Wheel Mechanism Replacement

### 1.5.1 Dual wheel mechanism removal and installation:

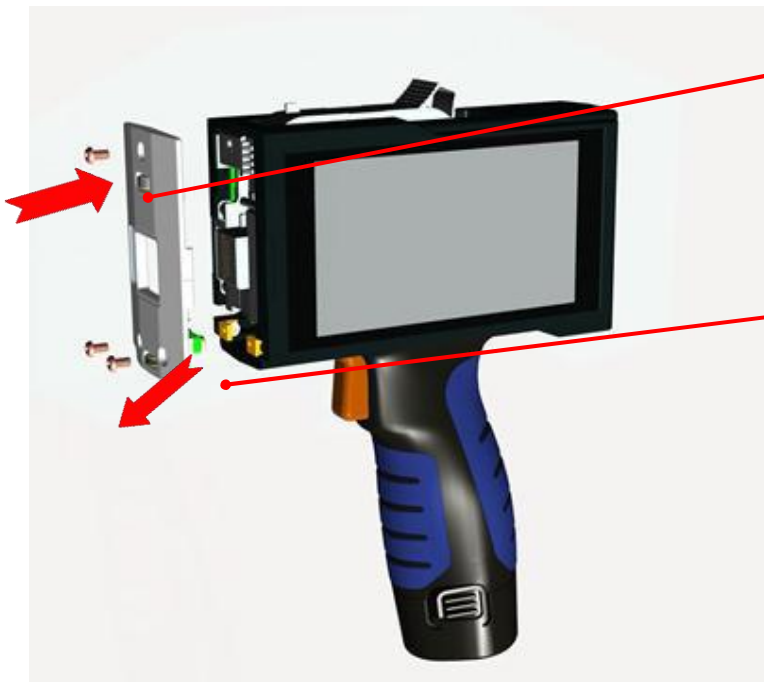

**Installation:**

As shown vertically inward install the dual wheel mechanism, and lock the screws.

**Removal:** Take off fixed screws, vertically outward pull the dual wheel mechanism.

### Well-installed dual wheel mechanism:



## 1.5.2 Four-wheel mechanism removal and installation

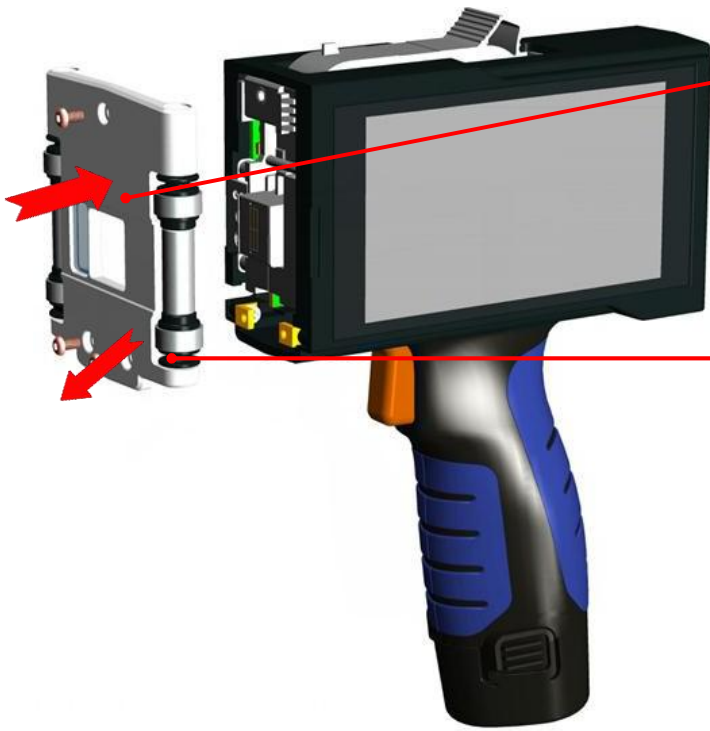

### **Installation:**

As shown vertically inward install the four-wheel mechanism, and lock the screws.

**Removal:** Take off fixed screws, vertically outward pull the four-wheel mechanism.

### **Well -installed four-wheel mechanism:**



# Inkjet Printer Introduction

## 2.1 Printer

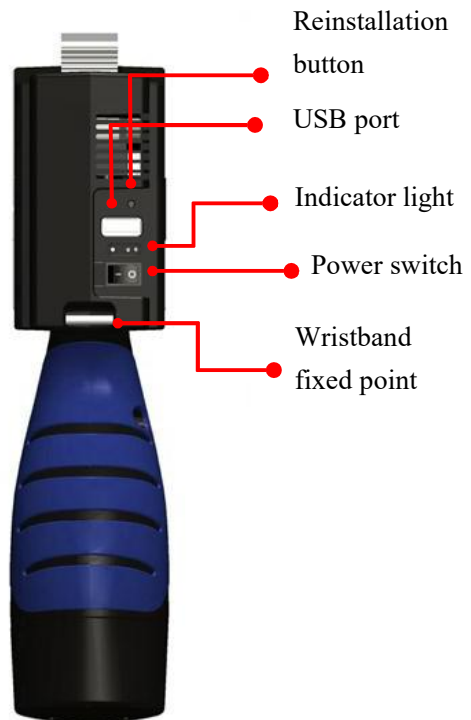
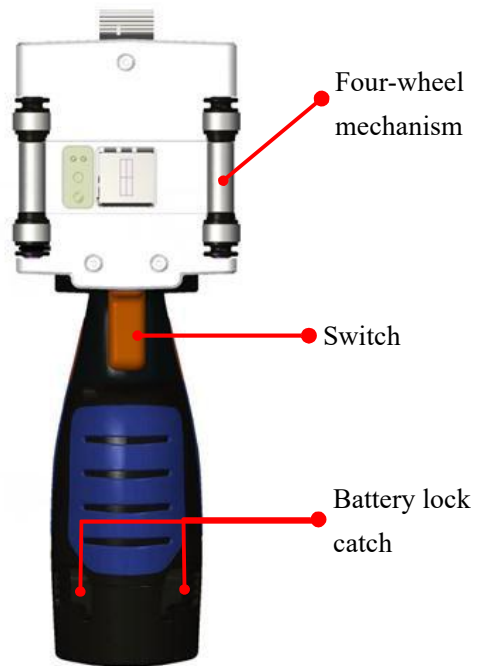

## 2.2 Technical Specifications

### 2.2.1 Performance Values

Items	Specifications		Note
Technical source	HP TIJ2.5 Thermal Ink Jet technology;		
Dimension	(H*W*D): 218*52*152mm; (H*W*D): 218*79*152mm (four-wheel mechanism included )		
Weight	0.74kg		
Power input	AC90V-240V, 50-60HZ		Specified Battery charger
Battery	Quantity	Two standard large capacity rechargeable batteries.	Charging time approximately 1.5H for full. The light is red when in charging the indicator light is yellow once power is full
	Capacity	3 section 2200mAh battery module	
	Voltage	11.1-12.6V	
	Lifetime	Approximately 300 cycles.	
	Standby time	Approximately 7H.	
	Working time	Approximately 4H.	
Print height	1-12.7mm		
Print speed and resolution	Standard 300DPI		
Print content	Barcode, alphabetic, numeric, Chinese, image, date, shift group, counter, scanner		
Ports	USB2.0 port		
Interface	5inch Capacitive touch screen with 1280*720 resolution		

Ink management	Automatically identify ink types and optimum printing parameters Guarantee genuine original HP ink; Automatically measure the status of ink usage	
Product Certification	CE, FCC	
Environment requirement	Working environment: -10°C--55°C; 10%-85%RH Storage environment: -25°C--80°C; 10%-90%RH	

## 2.2.2 Features

Items	Specification	Note
Languages	Chinese, English, French, German, Spanish, Portuguese, Russian, Korean and Japanese	
Font	Default font is Arial bold ; allow users to load whatever fonts they need	
Barcode	Code128, Code39, EAN8, EAN13, EAN128, UPCA, UPCE, INT25, Code93, ITF14, PDF417, DATAMATRIX, QRITF14, Code93  GrtidMatrix, GS1RSS1, GS1RSS14EX, GS1RSS14Limited, GS1RSS14Truncated, GS1EAN128, GS1RSS14Stacked, GS1RSS14StackedEX, GS1RSS14StackedOmni, GS1DM	
Date format	Variety of date formats available	
Multi-management	Customized different users and rights	

## 2.2.3 Ink Solutions

- Support 42ml cartridge of HP TIJ2.5 technology;
- Support ink of various colors: black, red, green, yellow and blue;
- Support porous, semi-porous and non-porous substrates.

---

# Printer Operation Instructions

## 3.1 Power on

Make sure the power is on before use printer, press the power switch, then enter the main interface.

If the printer screen is not light after turn on, it may be low battery, please charge it with specified charger.

## 3.2 Main Interface

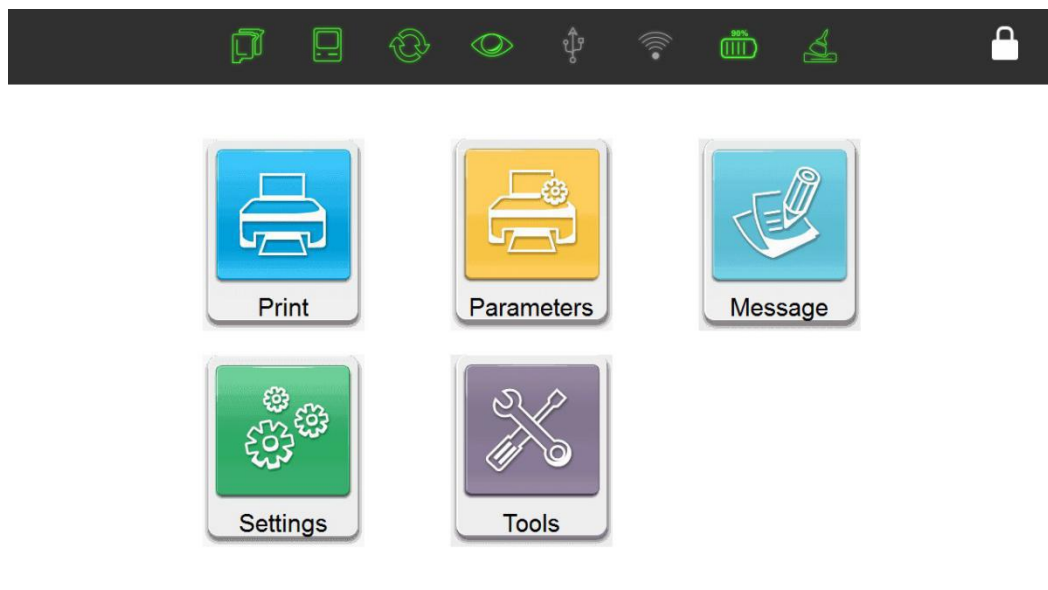

- **Printing:** List, start/stop print, print delay, print initial value, printing monitor, re-print.
- **Parameters:** Print setting, printhead setting, print options, special print.
- **Message:** List, new message, edit message, delete message, copy/paste message.
- **Setting:** Setting management, user management, system reset ,about.
- **Tools:** Image management, upgrade management, backup recovery, authority registration and plugin management.
- **Status bar:** Status of ink, equipment, encoder, photocell, USB, WI-FI, power and log off.

## 3.3 How to Upgrade Software(Refer to video “How to Upgrade Software”)

If you want to upgrade software, please do as below steps:

- First copy the installation package to the U disk path **【Inkjet/Upgrade/Application/ 】** .
- Insert the U disk into USB port of device, when the USB icon display green in the status bar,

dedicates that U disk has been identified by the device.

- Click **【Tools】** > **【Upgrade】** > **【Software】** , click the button **【Choose】** to enter the list of upgrade package.

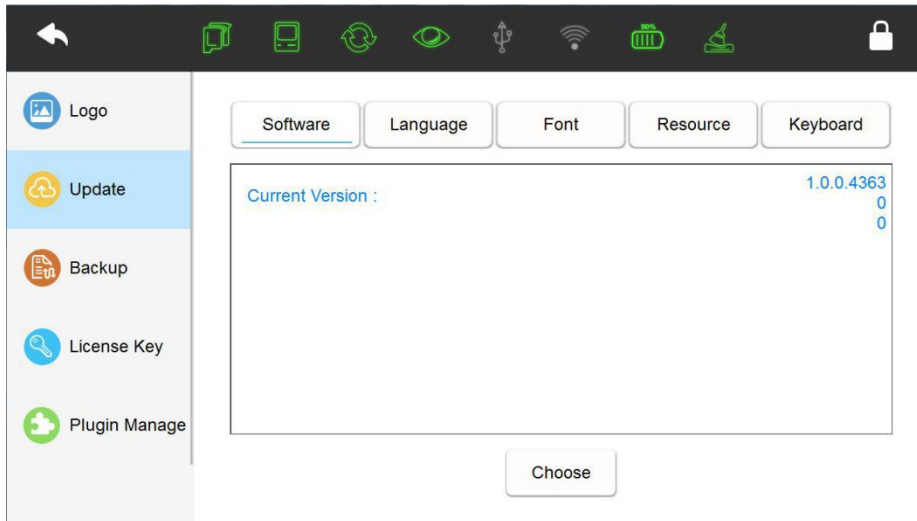

- Find your required upgrade installation package in the list, click button in the upper right corner, then you can upgrade.

- After upgrade successfully, the device will restart automatically, you can check whether the software version is what you need by **【Setting】** > **【About】**



Tips:

- Different printer only can be upgraded with corresponding install package, please take care in case of wrong upgrade.

- If installation package is not in the right specified path, click the button to enter the other folders, select the right upgrade package to upgrade. Please refer to [how to upgrade language, fonts and input method.](#)

## 3.4 How to Import / Export Data, Images, and Set Parameters

### 3.4.1 Data recovery/ Image / Print parameters / System parameters (Refer to video “recovery” )

- Save the backup file under the U disk path (Inkjet/backup/), insert U disk, and click **【Tools】** > **【Backup】**

- Select required recovery backup file from drop down list.

- Check recovery method, you can only choose one corresponding method, If you don't choose, it

won't recover corresponding type.

	Clear	Replace	Addition
Message	Clear all original data, only keep restoration data.	If restored data is with the same file name as original data, then restored data replace the original data and the file name unchanged	If restored data is with the same file name as original data, only add non-duplicate files, the data with same file name excluded
Image	Delete all original images, only keep restored images	If restored image is with the same file name as original then restored image replace the original and the file name unchanged	If restored image is with the same file name as original, only add non-duplicate files, the image with same file name excluded
Parameter		Restored parameters replace original parameters	
Setting		Restored parameters replace original parameters	

- Click **【Recovery】** to perform recovery operation. After recovery successfully, the device will reboot automatically, then the content of device will correspond with original file.



Tips:

- Save recovery file under the path: Inkjet/Backup/
- It is impossible to recover for File name exceeds 30 characters or contain symbols “\:\*?<>|”
- Data import via function of **【Message】** , please refer [Data Management](#) for details.
- Images import via **【Tools】 > 【Image】** , please refer [How to manage local images](#) for details.

### 3.4.2 Backup Data / Images / Print Parameters / System Parameters (Refer to video “Backup”)

- Insert U disk, click **【Tools】 > 【Backup】**
- Click required backup option, multi-optional available (backup will be failure if not select any options,)
- Backup name is available for 30 characters limit, English, numbers, symbols ( Except “\:\*?<>|” ) and Chinese, the backup name cannot be empty.

- 
- Click **【Backup】** and backup finish, save path under : Inkjet/Backup/



Tips:

- Backup files through export function of data list, please refer to [Data Management](#) for details
- Backup images through image management, please refer to [How to manage local images](#) for details

# Function Use Introduction

## 4.1 Message Management-Standard Mode

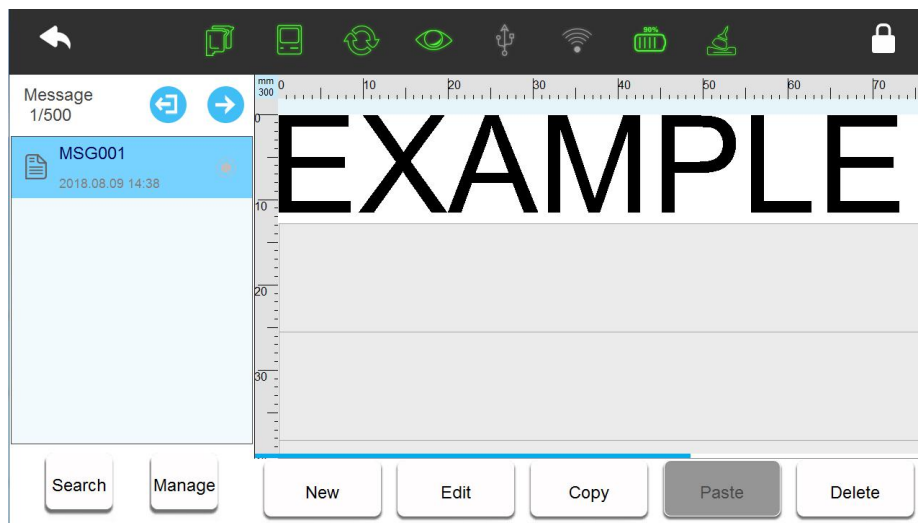

### 4.1.1 List Function

#### 4.1.1.1 Message List

Click **【Message】** > **【List】**

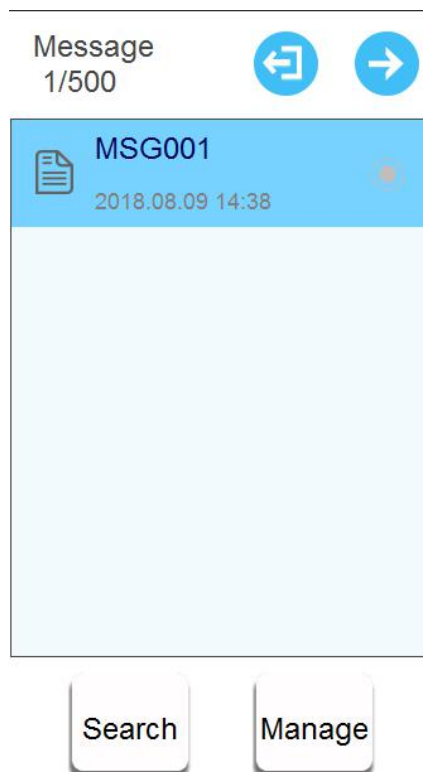





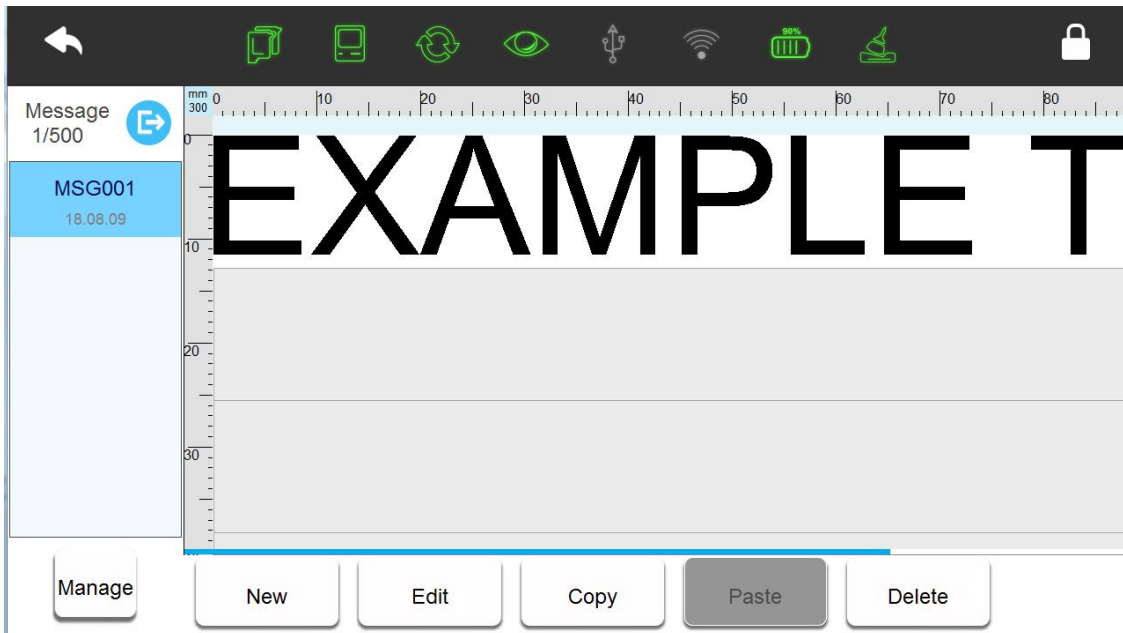

List mode switch: Display

message in the default way of list, click display mode;

【List】, and switch to icon



Click  【Icon】, can switch back to normal display mode; click  【Extended list】; click  【Restore normal list】;

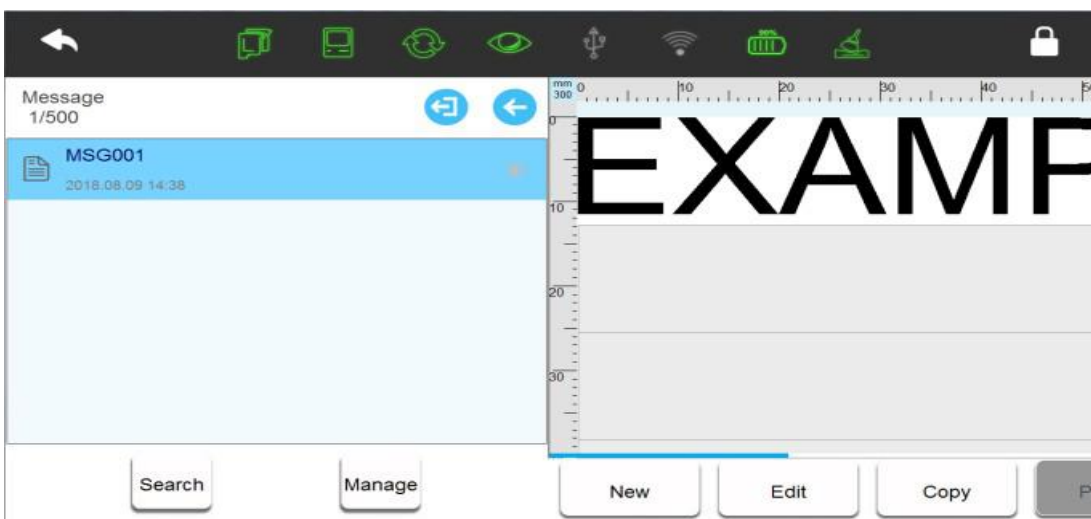

**Search message:** Click 【Search】, then popup search input box, enter keywords to match searching, then list will show exact message; After clear input box, list will display all messages.

**Message management:** Click 【Manage】, popup message management options; Click 【Manage】 again, and hide message management options.

**Import message:** Insert U disk, after device identify U disk, click 【Import】, and then message of U disk: Inkjet/msg will be imported into list automatically; When the import message name same with device, it will popup reminder, and choose whether to continue import according to reminder. (Refer to video “import and export message”)

**Export message:** Insert U disk, check needed imported message, click **【Export】**, then the selected message will be exported to U disk patch: Inkjet/msg. (Refer to video “import and export message”)

**Rename:** Select file, then click **【Rename】** , popup keyboard to edit message name, and take effect after save.

**Select all:** Click **【All】**, select all messages in the list automatically, switch button to **【None】**; Click **【None】** , selected messages will be canceled, then button switch back to **【All】** .



 **Tips:** Device maximum can save 500 messages, it can't continue add or import data after the message reach maximum.

#### 4.1.1.2 Object List

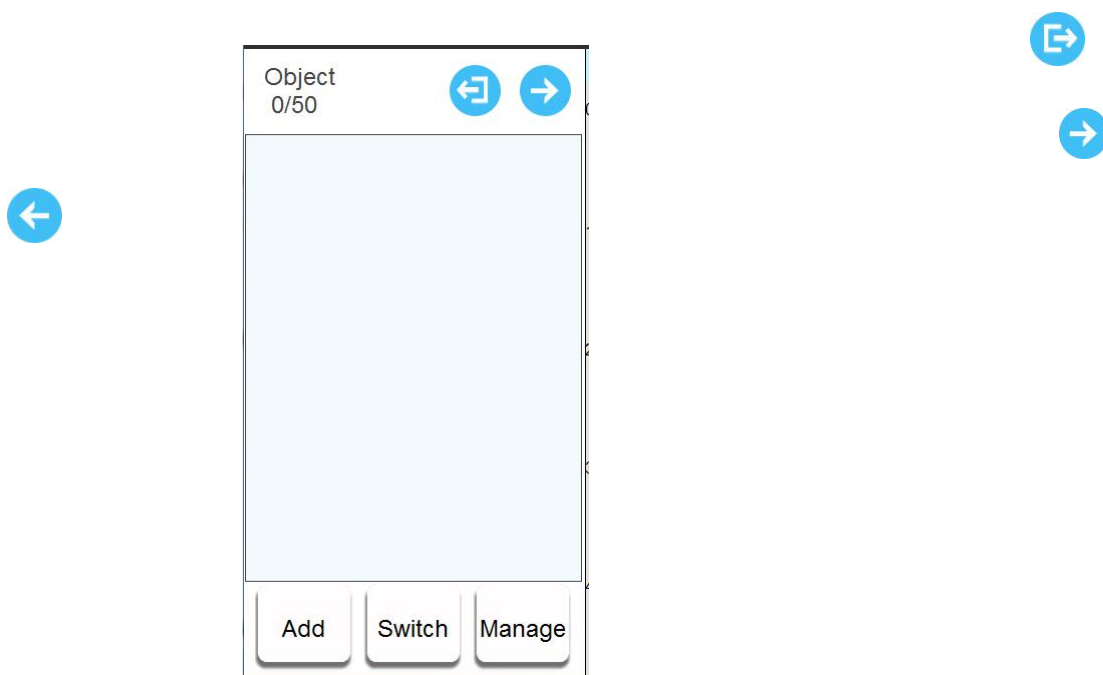
**【Message】 > 【List】** ,select message, click **【Edit】** or **【New】** , then messages list change to object list, display all objects of this message.



**Switch List Mode:** The data is displayed by default

in an simple way, Click the button  to switch to the standard list; Click the button  to switch back to the simple display mode; click on

extended list; click to  restore the normal list;

**Switch Source List:** Click **【Switch】** ,switch to source list, click **【Switch】** again, then can switch to object list.

**Object Arrangement:** Click **【Arrange】** , popup object alignment way, move up and down options.

**Edit Object:** Select the object in the list, and the interface will enter the object editing option.

Copy	Copy objects to the clipboard	Renam e	Rename object
Paste	Copy /paste or cut objects	Delete	Delete object

Select all	Select all objects	Unselect all	Unselect all object
Align	Object alignment		

## Source List

Enter [Switch source list](#) of object list according to above steps. Details refer to [Object list](#)

### 4.1.2 Toolbar

There are only three kinds buttons **【Zoom Out】** **【Zoom in】** **【Self-adaptive】** in the toolbar of message management preview and object edit; Except these three kinds button in the toolbar of new and edit message interface, there are **【Copy】** **【Paste】** **【Delete】** buttons.

Click  **【Tools】** , expand various shortcuts.

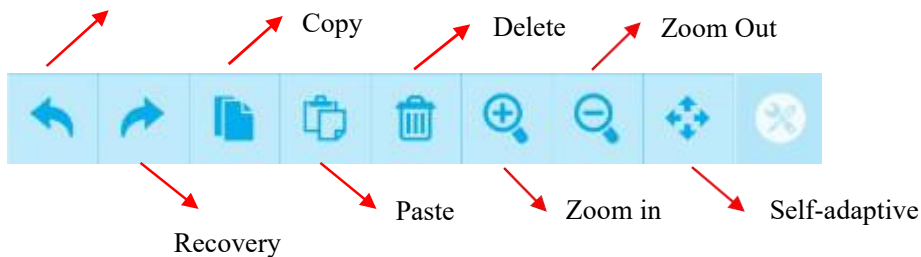

**【Copy】** : Click object/source in the preview interface, click **【Copy】** to clipboard.

**【Paste】** : Paste copy or cut object/source to the preview interface.

**【Delete】** : Click object/source in the preview interface, Click **【Delete】** , then will delete from the interface.

**【Zoom in】** : Enlarge 20% canvas size for every time clip.

**【Zoom out】** : Zoom out 20% canvas size for every time clip.

**【Adaptive screen】** : Display canvas size in 1:1 ratio.

Click  **【Tools】** again, the toolbar will be hidden

Click  every time, the preview interface will add one line canvas, multi-line data can be built to maximum 16 lines.

- Click  every time, the preview interface will reduce one line canvas. Edit multi-line data, please refer to the video “Edit multi-line data”.

### 4.1.3 New Text Message(Refer to the video “Add New Text Message”)

#### New Text Source

【Message】 > 【New】 > 【Source List】 > 【Add】 > 【Text】

**Enter text content:** Maximum can input 100 characters, you can input Chinese, English, numbers, symbols and third-party language.

**Source name:** Maximum 30 characters, you can input Chinese, English, numbers, symbols, and third-party language; Empty name and rename with added source are not allowed.

#### New Text Objects

【Add】 > 【Text】

The default display text content (EXAMPLE TEXT)

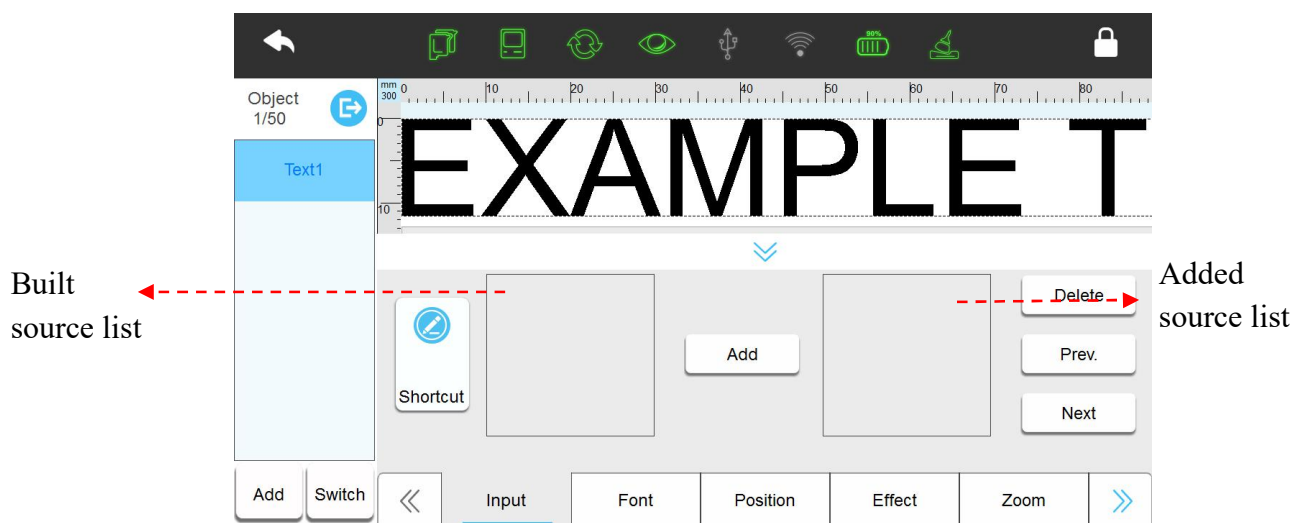

**Built Source List:** Show established source. Can be added directly to the object.

**Add the “Source” to the object:** Select the “source” which want to add in the built source list, click side **Add** 【Add】, then will add automatically to the preview interface and added list.

Note: Maximum can add 50 “sources”.

**Added Source List:** Display current source of object which has been added in order.

**Adjust the sources order of object:** Select “source” of list, click 【Prev.】 【Next】 to adjust order.

**Delete “source” of object:** Select source which need to be deleted in the added source list first, then click side button 【Delete】, a key to delete.





Click 【 Shortcut 】, switch to quick input interface. You can input Chinese, English, numbers, symbols, and third-party language, 100 characters limited. (Note: If you have already added the source in 【Routine】 interface, then the input is invalid.)

---

## Font



**Font:** Select the font, default is Default



**Size:** Set the font size or height, you can set the range 16-205, the default 190, the sub-high can set the range 1-12.7mm; you can select in the drop-down box or enter it yourself, or click the spin button.

**Effect:**  Bold,  Italic,  Add under horizontal line,  Add font with horizontal line

**Cut Edge:** Set whether the object with white lace.

### Effect



**Spacing:** Distance between words, you can enter 0-100, one decimal place. You can also click the   to fine-tune the precision by 0.1.



**Leading:** The distance between two lines. You can also click the   to fine-tune the precision by 0.1. Input range is limited depending on the canvas

### Text Alignment Way:

Left Align	Align multiple lines to the left
Middle Align	Align Multiple lines centering
Right Align	Align multiple lines to the right
Full Align	Align multiple lines left and right justification

## Position

**X axis coordinates:** Input range -10-3000mm, you can   buttons to adjust slightly.

**Y axis coordinates:** Input range according to canvas amount limited, also can click   buttons to adjust slightly.

## Zoom

**Width:** You can enter 10% to 300%, the greater value, the larger width font.



**Height:** You can enter 10% to 300%, the greater value, the higher font.

**Lock scale:** The proportion of font height and width. After select this function, when modify the font width or height, the font will be proportionally adjusted.



Tips: If the data location beyond the canvas, it will turn yellow, after saving only the content within the canvas can be printed.

### Others

**Rotation:** Input range 0-359, also can   buttons to adjust.

**Mirror:** There are None, Horizontal mirror, Vertical mirror three options, click the drop-down button to expand

**Gradation:** Printing darkness can be set within 10-100%.

### Name

It can be set to Chinese, English, numbers and symbols; cannot exceed 30 characters, empty and rename with added object are not allowed.

### Save Data

After create text object, return to new interface,  again, then enter to data name setting interface, you can input Chinese, English, numbers, symbols, third-party language, data name no more than 30 characters; Empty and rename with added data are not allowed.

After entering data name, click **【 Yes 】** in the upper right corner, the system will prompt data save successfully, then return to main interface! Click **【No】** , won't save, and then return to data interface. Click **【Cancel】** to return to the editing interface.



**Error data content (data red), the system will prompt an error, you can save after normal modify.**

## 4.1.4 Add Date/Time (Refer to the video “Add Date/Time”)

### Create Date/Time source (production date, expiry date)

**【Message】 > 【New】 > 【Source List】 > 【Add】 > 【Date Time】**

Select format: select format from the menu, system has 5 default formats, user can define totally 45 types. The default ones cannot be deleted or modified, default formats include: YYYYMMDD, YYYY/MM/DD, MM/DD/YYYY, HH:mm, Julian day.

**Add new format:** if user wants to add a new format or modify an exist one, click **【Edit】** , popup date format management list.

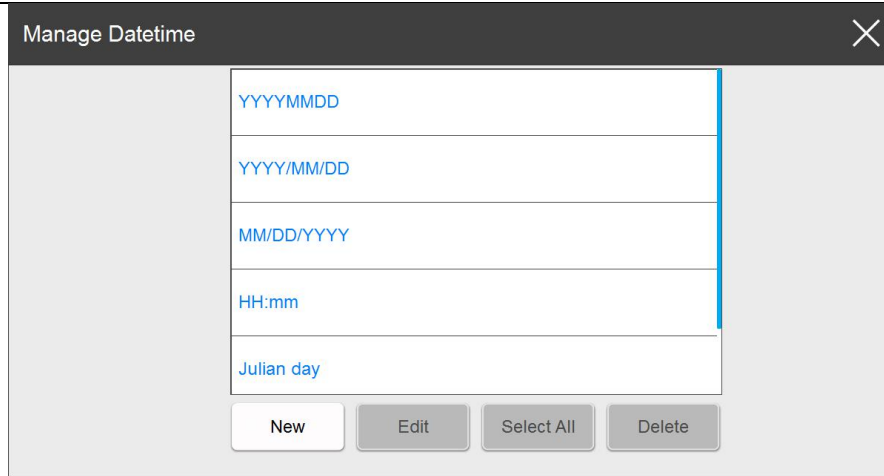

**Format List:** Display the default formats and newly added formats.

**New:** Click the new pop-up the date format setting keyboard, can choose a custom date format.

Format name enter no more than 30 characters, and cannot be input (" \ / : \*? "< > |"), and can't be empty, otherwise cannot be saved.

**Icons description:**

SN	Icon	Description	SN	Icon	Description
1		4-digit Year	10		Hour in 12 hour system
2		Last 3-digital Year	11		Minute
3		Last 2-digital Year	12		Second
4		Last 1-digital Year	13		the day of the week
5		Month 01-12	14		Abbreviation of the weekday
6		abbreviated month	15		AM/PM
7		Month name	16		Week of Year
8		Day	17		Name of weekday
9		Hour in 24-hour time system	18		Day of the year
			19		Keyboard

**Edit:** Choose date from the format list, and click "edit" popup the Settings interface, can modify and then save. The default format cannot be modified!

**Select all:** All formats in the list was chosen; Click the switch again change to all don't choose, all

---

not to choose.

**Delete:** Select the data format can be deleted. The default format cannot be deleted

**Closing date format management:** Click on close, out of date format management interface and save existing format.

**Expiry date:** If only want to add a production date, user may need to set the expiry day to 0; expiry time can switch from day, hour, month, year, value within 0-999.

**Calendar type:** Gregorian/ Hirji

**Pre-zero:** 4 choices: 2015/01/01, 2015/\_1/\_1, 2015/1\_/1\_, 2015/1/1

**Source name:** maximum 30 characters, Chinese and English characters, numbers, symbols, name cannot be blank or overlapped, or cannot be saved.

**Zero Setting:**

First enable the Zero Setting.

Input the time (hour: 0-23; minute: 0-59)

Then click the switch button again to get off this setting.

**Day Light Saving:**

User can select from OFF, Europe or America.

**Create Text object and add date time source.**

How to create a Text object and add date time source into it, please refer to [Create Text Object](#)

**Save Message**

Please refer to [Save Message](#)

#### 4.1.5 Add Counter (Refer to the video “Add Counter”)

**Add counter source**

【Message】 > 【New】 > 【Source List】 > 【Add】 > 【Counter】

**Initial Value:** begin value of the counter, range from -99999999999~+99999999999

**Maximum Value:** Maximum value, range from -99999999999~+99999999999

**Repeat Value:** range 0~9999

**Step Value:** for example: step value set to 3, counter will be 1, 4, 7, 11...

**Carry System:** User can select different carry systems, if need to add a new one, click 【Edit】

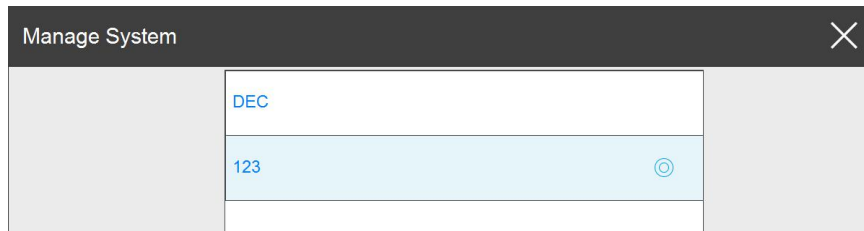

**System List:** Show the default and new built system. It can display a maximum of 5 (including the default base)

- **New:** Click “new” popup the system editing interface. Enter into the system name and content, click save to save the system to the list.

- **Edit:** Selected the system, click “edit” popup the editing interface, click “save” to save the changes. The default system cannot be edited.

**Select All:** All system in the list was chosen; Click the switch again change to all don't choose, all not to choose.

**Delete:** Select the newly systems can be deleted. The default system cannot be deleted

**Closing system management:** Click on close, out of management interface and save existing system.

**Counter Source name:** maximum 30 characters, Chinese and English characters, numbers, symbols, name cannot be blank or overlapped.

**Carry Source:** Click the pull-down menu to check the added counter.

Set the counter which the carry is based on (e.g there are counter 1 and counter 2, set the carry source of counter 2 to be counter 1, then only after counter 1 reached to the maximum value, counter 2 will carry over.)

**Current Value:** Set the current value of the counter, value should be within the begin value and maximum value.

**Repeat Index Value:** Set the current repeat index value, only settable while repeat value is not 0, repeat index value range is 0-repeat value.

**Pre-zero:** Pre-zero setting of counter, four options: 0001, \_\_\_1, 1\_\_\_, 1.

**Alarm:** Whether to give an alarm while counter reach the maximum value. User can switch this option on or off.

**Add Counter Source into Text**

Please refer to [Create Text Object](#)

## Save Message

Please refer to [Save Message](#)

### 4.1.6 Add Shift Object (Refer to the video “Add Shift Object”)

#### Add Shift Source

【Message】 > 【New】 > 【Source List】 > 【Add】 > 【Shift】

From the pull-down menu, user can check the already existed shifts, if need to create a new one or modify any of them, click 【Edit】



**Shift List:** Show the default and new built shift.

**New:** Building new shift

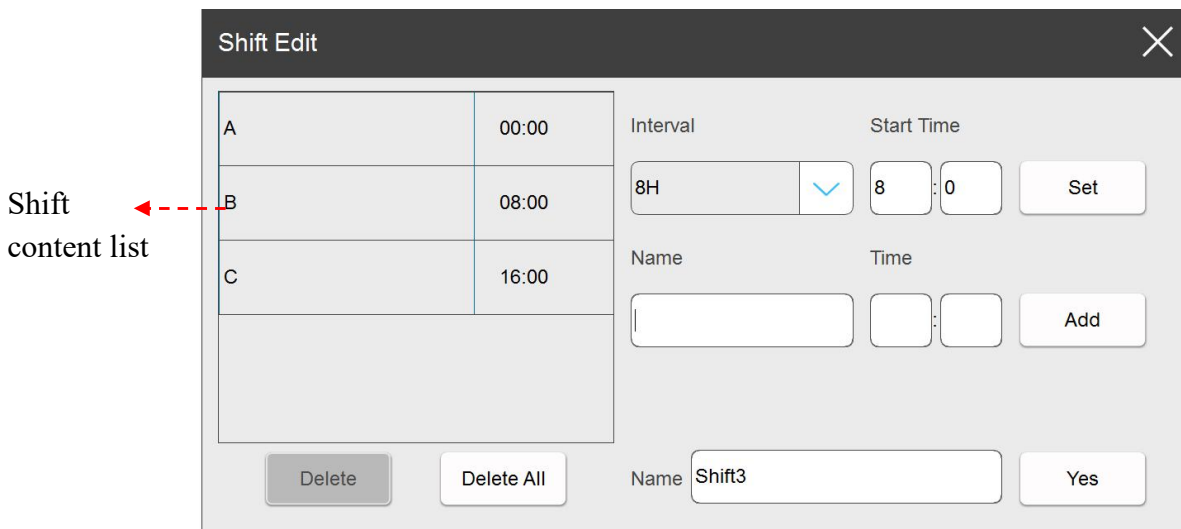

【Interval】 : According to the selected time interval, 24 hours a day is divided into the corresponding number of shifts. For example, the time interval is set to 4H, the system automatically generates 6 shifts (default A-F), and shows in the left list.

【Start Time】 : Time of first shift. For example, set the interval to 4H, the starting time is set to 8:00, then the first shift A start time is 8:00, shift B start time is 12:00, shift C start time is 16:00, and so

---

on.

**【Set】**: Select the time interval and the start time, click the button **【Set】**, will generate the default shifts automatically, and shows in the left list.

**【Add】** : If need to add another shift, you can input the **【Shift name】** and the **【Time】**, click **【Add】** , the new shift will be added to the list on the left side.

**【Shift content list】** : Show the current team all content; Maximum user can add 48 shifts.

**【Delete】** : If need to delete any shift, select that one in the list, click **【Delete】**

**【Delete all】** : If need to delete all exist shifts, click **【Delete All】**

**【 Modify Shift Content 】** : select the shift from the list on the left, then edit its content on the right side, **【Add】** will change to **【Modify】** ,click **【Modify】** to save

**【Shift name】**: Maximum 30 characters, can be Chinese, English letters, numbers or symbols (no special symbols).

**【Save shift】** : Click **【Save】** to save.

**Edit**: Selected the shift from the **【shift list】** , click “edit” popup the editing interface, click “save” to save the changes. The default shift cannot be edited.

**Select All**: All shifts in the list was chosen; Click the switch again change to all don't choose, all not to choose.

**Delete**: Select the newly shifts can be deleted. The default shift cannot be deleted

**Closing Shift Management**: Click on close, out of management interface and save existing shifts.

### **Shift Source Name**

Maximum 30 characters, Chinese or English characters, numbers, symbols, name cannot be blank or overlapped, or will not be saved.

### **Add Shift Source into Text**

Please refer to [Create Text Object](#)

### **Save Message**

Please refer to [Save Message](#)

## **4.1.7 Add Local Image Object(Refer to the video “Add Local Image Object”)**

### **Add Local Image**

**【Message】** > **【New】** > **【Source List】** > **【Add】** > **【Local Image】**

---

Select the image from the list.

Set the name of the local image source: Maximum 30 characters, Chinese or English characters, numbers, symbols, name cannot be blank or overlapped.

### Add Local Image in New Logo Object

【New】 > 【Object List】 > 【Add】 > 【Logo】

**Picture Setting:** The newly created image source will be displayed in the list, preview shows the selected image in the current position.



#### Position:



**Width ratio:** range from 10-300, the width of the picture will be adjusted automatically.

**Height ratio:** range from 10-300, the height of the picture will be adjusted automatically.

#### Zoom:

**Lock Percentage:** After selected, the height and width of the picture will be adjusted with the same proportion.

**X axis:** Range -10-3000mm, also can be adjusted the position by clicking the button   to adjust slightly.

**Y axis:** Range depends on the canvas size, also can be adjusted the position by clicking the button   to adjust slightly.

#### Other:

**Rotate:** rotation angel from 0-359, user also can be adjusted the position by clicking the button.

**Gradation:** Printing darkness can be set within 10-100%.

- **Name:** Maximum 30 characters, Chinese or English characters, numbers, symbols, name cannot be blank or overlapped.

### Save Message

Please refer to [Save Message](#)

Add shortcut image, please refer to the video “Add shortcut image”

## 4.1.8 Add Base Image (Refer to the video “Add Base Image”)

【Message】 > 【New】 > 【Source List】 > 【Add】 > 【Base Image】

【 Type 】: Four base images: Straight line, Rectangle, Circle and Ellipse. Select one of the base images, will be displayed in real-time in the left preview box.

【Edit】 : According to the selected base image, display the corresponding settings.

---

**Straight line:** Length: 1-3000mm. Line Width: 0.1-2mm.

**Rectangle:** Width: 1-3000mm. Height: 1-12.7mm **Circle:**

Diameter: 1-12.7mm

**Ellipse:** Long axis: the lateral diameter of the ellipse, 1-3000mm. Short axis: the vertical diameter of the ellipse, 1-12.7mm

**【Other】** : Settings of Rectangle or Circle or Ellipse

Chamfering: The range is 0-999, enter 0 is right angle, enter 999 is semicircle (Settings of Rectangle)

Fill/Stroke: Click the button to switch the Stroke and Fill. Set to Stroke, only show graphic borders.

Set to Fill, shows black graphic, line width setting is not available.

Line Width: the range is 0.1-2mm

**【Name】** Maximum 30 characters, Chinese or English characters, numbers, symbols, name cannot be blank or overlapped.

Add base image into logo object and save message please refer to [Create Local image object.](#)

#### **4.1.9 Add Device Name Object (Refer to the video “Add Device Name Object”)**

##### **Create Device Name Source**

**【Message】 > 【New】 > 【Source List】 > 【Add】 > 【Device Name】**

Generated the device name source directly, the default device information is INKJET. In the

**【System Management】 >【Set up Management】**modify equipment information, after save the source content updates automatically.

In each message can build only one device source. **Add Device Name Source into Text**

**Object** Please refer to [Create Text Object](#)

**Save Message**

Please refer to [Save Message](#)

#### **4.1.10 Add Scan Print Object (Refer to the video “Add Scan Print Object”)**

##### **Create Scan Print Source**

**【Message】 > 【New】 > 【Source List】 > 【Add】 > 【Scan print】**

---

**【Edit】 :**

**Preview:** The contents of the MSG preview, cannot be print out. Can enter any characters except the newline.

**【Other】 :**

**【Auto Sleep】 :** Make the device into the low power state. Default value is 1s, the range is 1-60s.

**【Read Time】 :** Default value is 3s, the range is 0-3600s.

**【Error Info】 :** Need to turn on the right switch before use. Only support for input in English.

**【Scan Delay】 :** Can be set 1-30s, scanning light is turned on, can not scan within the set time.

**Name:** Maximum 30 characters.

### **Add Scan Print Source into New Text Object**

Please refer to [Create Text Object](#)

### **Save Message**

Please refer to [Save Message](#)

### **Print Scan Message (Refer to the video “Print Scan Message”)**

Click start to print, shake the printer the scan light will on, after scan the barcode, light will be off, push the red button, the message will be printed. If not recognize the barcode, printer will scan for several times, if no sense for 10s, scan light will be off as well.



Note: One message can only contain one piece scan print source, user can set the scan cache numbers, the scan message can only print once.

## **4.1.11 Add Dynamic Text Source**

### **Create Barcode Object**

• **【Message】 > 【New】 > 【Object List】 > 【Add】 > 【Dyn. Text】**

• **【Edit】 :**

**Preview:** The default text content is DYNAMIC TEXT, click to enter a modified preview.

• **【Name】** Maximum 30 characters, Chinese or English characters, numbers, symbols, name cannot be blank or overlapped.

• **【Other】 :**

**Interface:** The default is Ethernet/Standard Protocol

### **Create a Text Object to Add Dynamic Text**

Please refer to [New Text Object](#).

## Save Message

Please refer to [Save Message](#)

### 4.1.12 Add Barcode (Refer to the video “Add Barcode”)

#### Create Barcode Object

【Message】 > 【New】 > 【Object List】 > 【Add】 > 【Barcode】

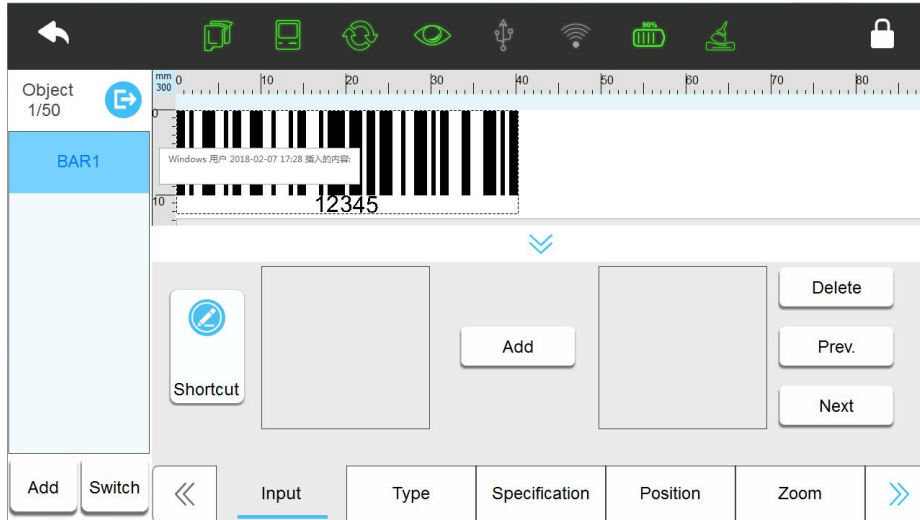

【 Shortcut 】 : Can add Text/Counter/Shift/Data Time/Dynamic Text/ Scan Print /Device Info/line break into barcode object. (Tip: Add scan source and scan the illegal value, the scan source will change to 00000 in the bar code)

Note: Refer to above create text object about add “source”.

#### 【Type】

Click 【type】 to select the required barcode type.

- Click 【Genre】 , user can select 1Dbarcode, 2D barcode. GS1 barcode. GS1 2D barcode.
- User will see the barcode types required.

#### Barcode Settings



Note: 1D and 2D barcodes have different settings, user need to select barcode genre firstly.

Bar code category	Settings
-------------------	----------

Ordinary/ GS1 1D Barcode	<p><b>Width:</b> Totally 1-16 levels to choose from.</p> <p><b>Height:</b> Within the canvas size,1-12.7mm</p> <p><b>Font:</b> Select barcode text font</p> <p><b>Font Size:</b> Select barcode text font size.</p> <p><b>Text Display:</b> User can switch from on or off.</p> <p><b>Cut Edge:</b> Select barcode whether with white lace</p> <p><b>Blank Level:</b> 0-4 grades to switch.</p>
Ordinary/ GS1 2D Barcode	<p><b>Width:</b> Totally 1-16 levels to choose from.</p> <p><b>Error Correction Level:</b> QR code, 1-4 grades; PDF417, 1-7 grades.</p> <p><b>Blank Level:</b> 0-4 grades to switch.</p> <p><b>Size:</b> QR, DATAMATRIX bar code size specifications.</p>

- **Layout, Other, Name please refer to [Create Text Object](#)**

### Save Message

Please refer to [Save Message](#)

Add line break, please refer to the video “Add line break”

### 4.1.13 Edit Message

Click **【Message】** from the main interface, then click **【List】** to see all the messages added.

Select the message, and click **【Edit】**

**【New Object】** : Please refer to [Add New Message](#)

**【Edit Object】** : select the object need to edit in the list

**【New Source】** : Please refer to [Add New Message](#)

**【Edit Source】** : Select source in **【Source list】**

After editing, click return, choose save or not.

 **Tips:** When the MSG with dynamic source (Counter, Device Info, Date Time, Scan, Shift) has print records, edit this MSG and save it, will prompt to **【Save】** **【Not Save】** **【Save As】** **【Cancel】** options. Select **【Save As】** to retain the original MSG, and create a new MSG. Select **【Save】**, the original MSG will

---

be covered, the print records is cleared and cannot be reprinted.

#### 4.1.14 Copy/Paste Message

Select the message in list, click **【Copy】** , and then click any position in the list, click **【Paste】** , the message will be copied and named as the original one with “C1” at the end. For example, if original message is MSG001, the copied one will be named as “MSG001C1”.

Can do multiple choice, copy and paste them at the same time.

If copied several times, only the last copied message(s) will be pasted.

#### 4.1.15 Delete Message

Select the message(s) in the list, click **【Delete】** , yes to delete or no to cancel.

### 4.2 Message Management-Simple Mode

Set Simple Mode, please refer to the video “Set Simple Mode”

#### List Function

##### 4.2.1 Message List

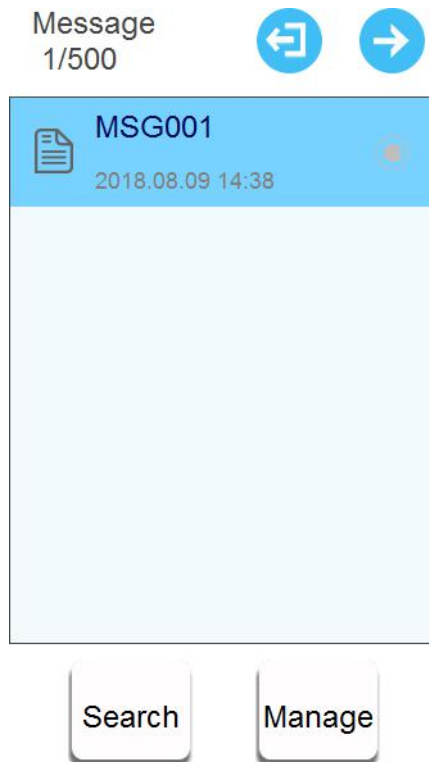

Click **【Message】** > **【List】**

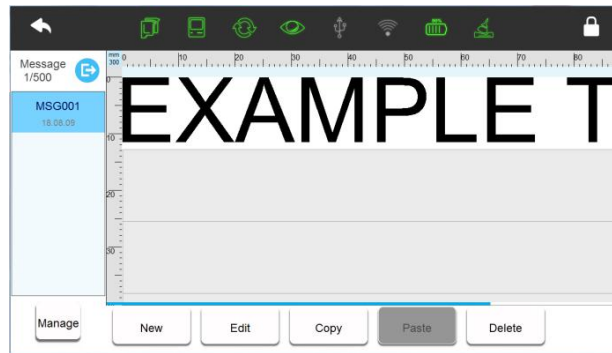

- List mode switching: Display message in the default way of list, click  **【List】**, and switch to icon

display mode;



Click  **【Icon】**, can switch back to list display mode; Click  **【Unfold】** button, the list width will be expanded, then can display completely message name; Click  **【Recovery】** again, then return back to normal width.

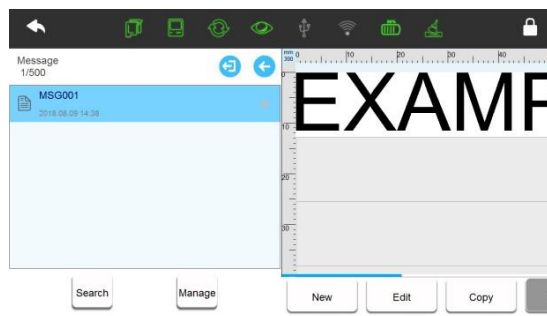

- **Search message:** Click **【Search】**, then popup search input box, enter keywords to match searching, then list will show exactly message; After clear input box, list will display all messages.

- **Message management:** Click **【Manage】**, popup message management options; Click **【Manage】** again, and hide message management options.

**Import message:** Insert U disk, after device identify U disk, click **【Import】**, and then message of U disk: Inkjet/msg will be imported into list automatically; When the import message name same with device, it will popup reminder, and choose whether to continue import according to reminder.

**Export message:** Insert U disk, check needed imported message, click **【Export】**, then the selected message will be exported to U disk patch: Inkjet/msg

**Rename:** Select file, then click **【Rename】**, popup keyboard to edit message name, and take effect after save.

**Select all:** Click **【All】**, select all messages in the list automatically, switch button to **【None】**; Click **【None】**, selected messages will be canceled, then button switch back to **【All】**.



Tips: Device maximum can save 500 messages, it can't continue add or import data after the





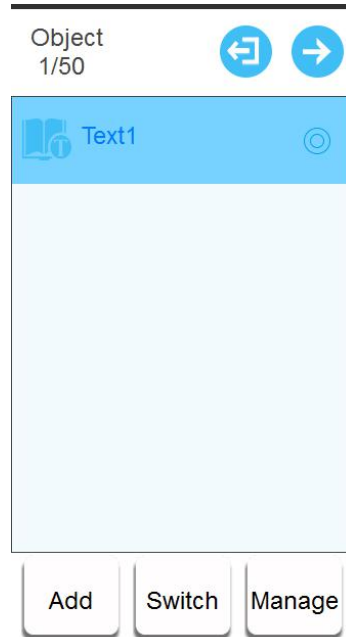

message reach maximum.

### 4.2.2 Object List









【Message】 > 【List】 ,select message, click 【Edit Message】 or 【New Message】 , then messages list change to object list, display all objects of this message.







• **Object Management:** Click 【Manage】 , selectable object editing shortcuts.

	Copy objects to the clipboard		Rename objects
	Copy-paste or cut objects		Delete Objects
	Select all Objects		Select none
	Object alignment		

### Sort Keypad Description:

SN.	Icon	Description	SN.	Icon	Description
1		Align selected objects to the left	5		Arrange selected objects align to top
2		Arrange selected objects centered around aligned	6		Arrange selected objects align center up and down
3		Align selected objects to the right	7		Arrange selected objects align bottom
4		Arrange selected objects vertical distribution	8		Arrange selected objects transverse distribution

• **List Mode Switching:** Display message in the default way of list, click  **【List】**, and switch to standard list;  **【Icon】**, can switch back to simple display mode, if only  **【Unfold】**, the list will be expanded, and display completely; Click  **【Recover】** again, then can recover to normal;

• **Add:** Click **【 Add 】**, entering the corresponding editing interface, can choose to build objects(Text, Barcode, Shift, Counter, Logo, Date/Time, Scan Print)

• **Object Edit:** The object is selected in the list, and the interface corresponds to the object editing option.

### 4.2.3 Toolbar

In the date management preview, object editing toolbar, it only have three buttons, that is **【 Enlarge 】** **【Narrow】** **【Adaption】**; In addition to the three functions of new built edit data interface, the toolbar is also have **【copied】**, **【sticker】**, and **【deleted】**.

• Click  **【Tools】**, expand various shortcuts.

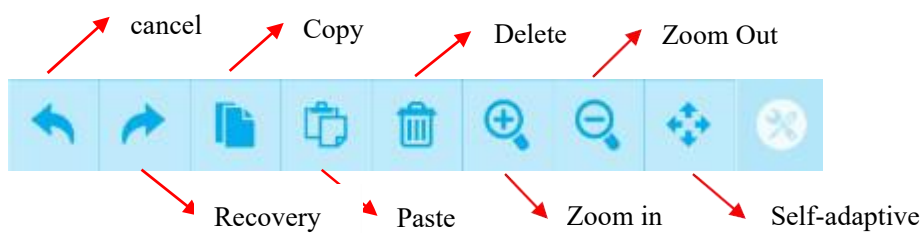

**【Copy】** : Click object/source in the preview interface, click **【Copy】** to clipboard.

**【Paste】** : Paste copy or cut object/source to the preview interface.

**【Delete】** : Click object/source in the preview interface, Click **【Delete】**, then will delete from the interface.

**【Zoom in】** : Enlarge doubled canvas size in the standard state.

**【Zoom out】** : Click Zoom out in the enlarge canvas, then will restore to standard state canvas.

**【Adaptive screen】** : Display canvas size in 1:1 ratio.

• Click  **【Tools】** again, the toolbar will be hided.

• Click  every time, the preview interface will add one line canvas, multi-line data can be built to maximum 16 lines.

• Click  every time, the preview interface will reduce one line canvas.

Edit multi-line data, please refer to the video “Edit multi-line data”.

---

## 4.2.4 New Message (Refer to the video “Add new message in simple mode”)

- **【Message】** > **【New】** > **【Object List】** > **【Add】**
- Select object jump out of the setting interface (text, counter, date time, shift, scan, barcode, local picture)
- Multiple clicks can be added to multiple objects.
- Selected object in the object list , jump out of corresponding settings interface.
- Click  to save message and return to the message management interface.

### 4.2.4.1 Text object

- **【Message】** > **【New】** > **【Object List】** > **【Add】** > **【Text】**
- **【Input】** : Default text content : EXAMPLE TEXT, can enter Chinese, English, numbers, symbols, other language, 100 characters.

- **【Front】** :

**Font:** Select the font.



**Size:** Set the font size.



**Front Size:** Set the front size or front height, can set the front size 16-300, the default is 190; front height 1-12.7mm, can choose from the drop down list or enter it yourself.

**Font effect:** Bold, Italic, Add under horizontal line, Add font with horizontal line

**Cut Edge:** Set whether the objet with white lace.

- **【Position】**

**X axis coordinates:** Input range -10-3000mm, you can click   buttons to adjust slightly.

**Y axis coordinates:** Input range according to canvas amount limited, also can click   buttons to adjust slightly.

- **【Zoom】**

**Width:** You can enter 10% to 300%, the greater value, the larger width font.



**Height:** You can enter 10% to 300%, the greater value, the higher font.

**Lock scale:** The proportion of font height and width. After select this function, when modify the font width or height, the font will be proportionally adjusted.



Tips: If the data location beyond the canvas, it will turn yellow, after saving only the content within the canvas can be printed.

- **【Other】**

**Rotation:** Input range 0-359, also can click   buttons to adjust.

**Mirror:** There are None, Horizontal mirror, Vertical mirror three options, click the drop-down button to expand

**Gradation:** Printing darkness can be set within 10-100%.

- **【Paragraph】**

**Spacing:** Distance between words, you can enter 0-100, one decimal place

**Leading:** The distance between two lines. Input range is limited depending on the canvas

**Text Alignment Way:**

Left Align	Align multiple lines to the left
Middle Align	Align Multiple lines centering
Right Align	Align multiple lines to the right
Full Align	Align multiple lines left and right justification

- **【Name】**

It can be set to Chinese, English, numbers and symbols; cannot exceed 30 characters, empty and rename with added object are not allowed.

#### 4.2.4.2 Counter object (Refer to the video “Add Counter in simple mode”)

- **【Message】 > 【New】 > 【Object List】 > 【Add】 > 【Counter】**

- **【Input】** : Input contents represents the counter.

- **【Routine】** :

**Initial Value:** begin value of the counter, range from -999999999999~+999999999999



**Maximum Value:** Maximum value, range from -999999999999~+999999999999

**Repeat Value:** range 0~9999

**Step Value:** for example: step value set to 3, counter will be 1, 4, 7,11...

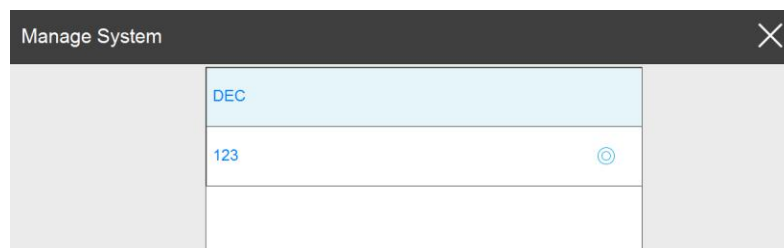
**Carry System:** User can select different carry systems, if need to add a new one, click **【Edit】**



- 
- **System List:** Show the default and new built system. It can display a maximum of 5 (including the default base)
  - **New:** Click “new” popup the system editing interface. Enter into the system name and content, click save to save the system to the list.
  - **Edit:** Selected the system, click “edit” popup the editing interface, click “save” to save the changes. The default system cannot be edited.
  - **Select All:** All system in the list was chosen; Click the switch again change to all don't choose, all not to choose.
  - **Delete:** Select the newly systems can be deleted. The default system cannot be deleted
  - **Closing system management:** Click on close, out of management interface and save existing system.
  - **【Advance】 :**
    - Carry Source:** Click the pull-down menu to check the added counter.  
Set the counter which the carry is based on (e.g there are counter 1 and counter 2, set the carry source of counter 2 to be counter 1, then only after counter 1 reached to the maximum value, counter 2 will carry over.)
    - Current Value:** Set the current value of the counter, value should be within the begin value and maximum value.
    - Repeat Index Value:** Set the current repeat index value, only settable while repeat value is not 0, repeat index value range is 0-repeat value.
    - Pre-zero:** Pre-zero setting of counter, four options: 0001,\_\_\_1, 1\_\_\_, 1.
    - Alarm:** Whether to give an alarm while counter reach the maximum value. User can switch this option on or off.
  - **【Front】 :**
    - Font:** Select the font.
    - Size:** Set the font size.
    - Font effect:** Bold, Italic, Add under horizontal line, Add font with horizontal line
    - Cut Edge:** Set the objet with/without white edge
  - **【Position】**
    - X axis coordinates:** Input range -10-3000mm, you can click   buttons to adjust slightly.



**Y axis coordinates:** Input range according to canvas amount limited, also can click buttons to adjust slightly.

- **【Zoom】**

**Width:** You can enter 10% to 300%, the greater value, the larger width font.



**Height:** You can enter 10% to 300%, the greater value, the higher font.

**Lock scale:** The proportion of font height and width. After select this function, when modify the font width or height, the font will be proportionally adjusted.



Tips: If the data location beyond the canvas, it will turn yellow, after saving only the content within the canvas can be printed.

- **【Other】**

**Rotation:** Input range 0-359, also can click   buttons to adjust.

**Mirror:** There are None, Horizontal mirror, Vertical mirror three options, click the drop-down button to expand

**Gradation:** Printing darkness can be set within 10-100%.

- **【Paragraph】**

**Spacing:** Distance between words, you can enter 0-100, one decimal place

**Leading:** The distance between two lines. Input range is limited depending on the canvas

**Text Alignment Way:**

Left Align	Align multiple lines to the left
Middle Align	Align multiple lines centering
Right Align	Align multiple lines to the right
Full Align	Align multiple lines around

- **【Name】**

You can set Chinese, English, numbers and symbols; not exceed 30 characters, empty and rename with added object not allowed.

#### 4.2.4.3 Date/Time object (Add Date & Time in simple mode)

- **【Message】 > 【New】 > 【Object List】 > 【Add】 > 【Date/Time】**

- **【Input】** : Input contents represents the date object.

- **【Routine】** :

**Format:** select format from the menu, system has 5 default formats, user can define totally 45 types. The default ones cannot be deleted or modified, default formats include: YYYYMMDD, YYYY/MM/DD, MM/DD/YYYY, HH:mm, Julian day.

**Add new format:** if user want to add a new format or modify an exist one, click, **【 Edit 】** out of date format management list.

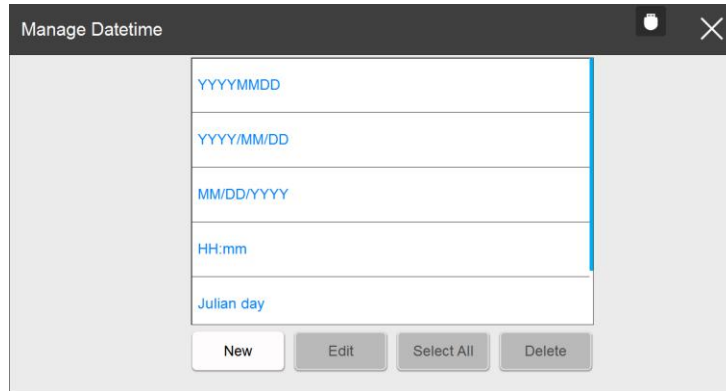



**Format List:** Display the default formats and newly added formats.(up to 50, including default format)

**New:** Click the new pop-up the date format setting keyboard, can choose a custom date format. Format name enter no more than 30 characters, and cannot be input (" \ / : \*? "< > |"), and can't be empty, otherwise cannot be saved.

**Icons description:**

SN	Icon	Description	SN	Icon	Description
1	YYYY	4-digit Year	10	hh	Hour in 12 hour system
2	_YYY	Last 3-digital Year	11	mm	Minute
3	__YY	Last 2-digital Year	12	ss	Second
4	___Y	Last 1-digital Year	13	W <sup>NO</sup>	the day of the week
5	MM	Month 01-12	14	W <sup>EN</sup>	Abbreviation of the weekday
6	M <sup>EN</sup>	abbreviated month	15	AM/PM	AM/PM
7	M <sup>ALL</sup>	Month name	16	W'st	Week of Year
8	DD	Day	17	W <sup>ALL</sup>	Name of weekday

9		Hour in 24-hour time system	18		Day of the year
			19		Keyboard

**Edit:** Choose date from the format list, and click "edit" popup the Settings interface, can modify and then save. The default format cannot be modified!

**Select all:** All formats in the list was chosen; Click the switch again change to all don't choose, all not to choose.

**Delete:** Select the data format can be deleted. The default format cannot be deleted

**Closing date format management:** Click on close, out of date format management interface and save existing format.

**Expiry date:** If only want to add a production date, user may need to set the expiry day to 0; expiry time can switch from day, week, month, year, value within 0-999.

**Calendar type:** Gregorian/ Hirji

**Pre-zero:** 4 choices: 2015/01/01, 2015/\_1/\_1, 2015/1\_/1\_, 2015/1/1\

- **【Date/Time】 :**

**Zero Setting:** Enable the Zero Setting, Input the time (hour: 0-23; minute: 0-59)

**Day Time Saving:** User can select from OFF, Europe or America.

- **【Front】 :**



**Font:** Select the font.



**Size:** Set the font size.

**Font effect:**  Bold,  Italic,  Add under horizontal line,  Add font with horizontal line

**Cut Edge:** Set whether the objet with white lace.

- **【Position】**

**X axis coordinates:** Input range -10-3000mm, you can click   buttons to adjust slightly.

**Y axis coordinates:** Input range according to canvas amount limited, also can click   buttons to adjust slightly.

- **【Zoom】**

**Width:** You can enter 10% to 300%, the greater value, the larger width font.

**Height:** You can enter 10% to 300%, the greater value, the higher font.



---

**Lock scale:** The proportion of font height and width. After select this function, when modify the font width or height, the font will be proportionally adjusted.



Tips: If the data location beyond the canvas, it will turn yellow, after saving only the content within the canvas can be printed.

- **【Other】**

**Rotation:** Input range 0-359, also can click   buttons to adjust.

**Mirror:** There are None, Horizontal mirror, Vertical mirror three options, click the drop-down button to expand

**Gradation:** Printing darkness can be set within 10-100%.

- **【Paragraph】**

**Spacing:** Distance between words, you can enter 0-100, one decimal place

**Leading:** The distance between two lines. Input range is limited depending on the canvas

**Text Alignment Way:**

Left Align	Align multiple lines to the left
Middle Align	Multiple lines align centered
Right Align	Align multiple lines to the right
Full Align	Align multiple lines around

- **【Name】**

It can be set to Chinese, English, numbers and symbols; cannot exceed 30 characters, empty and rename with added object are not allowed.

#### 4.2.4.4 Shift object (Add Shift object in simple mode )

- **【Message】 > 【New】 > 【Object List】 > 【Add】 > 【Shift】**

- **【Input】** : Input contents represents the shift object.

- **【Routine】** :

**Shift:** From the pull-down menu, user can check the already existed shifts, if need to create a new one or modify any of them, click **【Edit】**

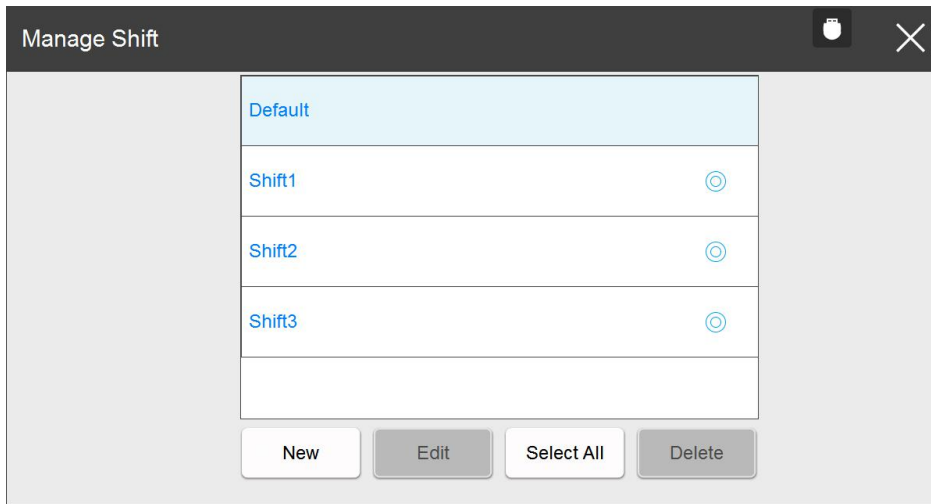

**Shift List:** Show the default and new built shift.

**New:** Building new shift

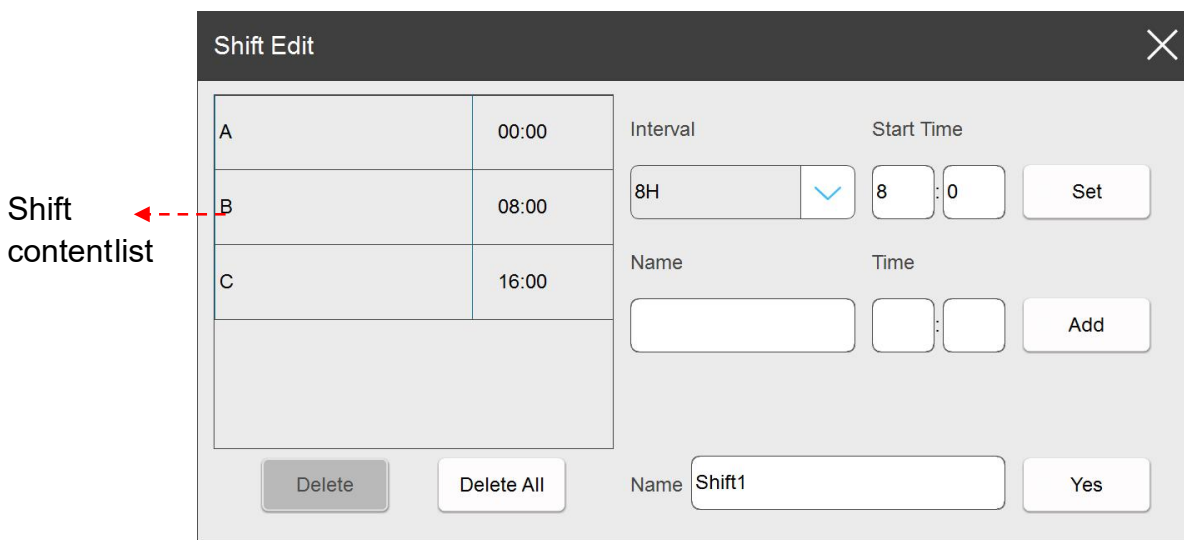

- **【Interval】** : According to the selected time interval, 24 hours a day is divided into the corresponding number of shifts. For example, the time interval is set to 4H, the system automatically generates 6 shifts (default A-F), and shows in the left list.
- **【Start Time】** : Time of first shift. For example, set the interval to 4H, the starting time is set to 8:00, then the first shift A start time is 8:00, shift B start time is 12:00, shift C start time is 16:00, and so on.
- **【Set】**: Select the time interval and the start time, click the button **【Set】**, will generate the default shifts automatically, and shows in the left list.
- **【add】** : If need to add another shift, you can input the **【shift name】** and the **【time】** , click **【Add】** , the new shift will be added to the list on the left side.

- **【shift content list】** : Show the current team all content; Maximum user can add 48 shifts.
- **【delete】** : If need to delete any shift, select that one in the list, click **【Delete】**
- **【delete all】** : If need to delete all exist shifts, click **【Delete All】**
- **【 Modify Shift Content 】** : select the shift from the list on the left, then edit its content on the right side, **【Add】** will change to **【Modify】** ,click **【Modify】** to save
- **【shift name】** : Maximum 30 characters, can be Chinese, English letters, numbers or symbols (no special symbols).

- **【Save shift】** : Click **【Yes】** to save.

**Edit:** Selected the shift from the **【shift list】** , click “edit” popup the editing interface, click “save” to save the changes. The default shift cannot be edited.

**Select All:** All shifts in the list was chosen; Click the switch again change to all don't choose, all not to choose.

**Delete:** Select the newly shifts can be deleted. The default shift cannot be deleted

**Closing Shift Management:** Click on close, out of management interface and save existing shifts.

- **【Front】** :



**Font:** Select the font.



**Size:** Set the font size.

**Font effect:** Bold, Italic, Add under horizontal line, Add font with horizontal line

**Cut Edge:** Set whether the objet with white lace.

- **【Position】**

**X axis coordinates:** Input range -10-3000mm, you can click   buttons to adjust slightly.

**Y axis coordinates:** Input range according to canvas amount limited, also can click   buttons to adjust slightly.

- **【Zoom】**

**Width:** You can enter 10% to 300%, the greater value, the larger width font.

**Height:** You can enter 10% to 300%, the greater value, the higher font.

**Lock scale:** The proportion of font height and width. After select this function, when modify the font width or height, the font will be proportionally adjusted.



**Tips:** If the data location beyond the canvas, it will turn yellow, after saving only the

---

content within the canvas can be printed.

- **【Other】**

**Rotation:** Input range 0-359, also can click buttons to adjust.

**Mirror:** There are None, Horizontal mirror, Vertical mirror three options, click the drop-down button to expand

**Gradation:** Printing darkness can be set within 10-100%.

- **【Paragraph】**

**Spacing:** Distance between words, you can enter 0-100, one decimal place

**Leading:** The distance between two lines. Input range is limited depending on the canvas

**Text Alignment Way:**

Left Align	Align multiple lines to the left
Middle Align	Multiple lines align centered
Right Align	Align multiple lines to the right
Full Align	Align multiple lines around

- **【Name】**

It can be set to Chinese, English, numbers and symbols; cannot exceed 30 characters, empty and rename with added object are not allowed.

#### 4.2.4.5 Scan print object (Refer to the video “Add Scan Print Object in simple mode”)

- **【Message】 > 【New】 > 【Object List】 > 【Add】 > 【scan print】**

- **【Input】 :** Input contents represents the scan object.

- **【Routine】 :**

**Auto Sleep:** Make the device into the low power state. Default value is 1s, the range is 1-60s.

**Read Time:** Default value is 3s, the range is 0-3600s.

**Error Info:** Need to turn on the right switch before use. Only support for input in English.

- **【Front】 :**

**Font:** Select the font.



**Size:** Set the font size.



**Font effect:** Bold, Italic, Add under horizontal line, Add font with horizontal line

**Cut Edge:** Set whether the objet with white lace.

- **【Position】**

---

**X axis coordinates:** Input range -10-3000mm, you can click   buttons to adjust slightly.

**Y axis coordinates:** Input range according to canvas amount limited, also can click   buttons to adjust slightly.

- **【Zoom】**

**Width:** You can enter 10% to 300%, the greater value, the larger width font.

**Height:** You can enter 10% to 300%, the greater value, the higher font.

**Lock scale:** The proportion of font height and width. After select this function, when modify the font width or height, the font will be proportionally adjusted.



Tips: If the data location beyond the canvas, it will turn yellow, after saving only the content within the canvas can be printed.

- **【Other】**

**Rotation:** Input range 0-359, also can click buttons to adjust.

**Mirror:** There are None, Horizontal mirror, Vertical mirror three options, click the drop-down button to expand

**Gradation:** Printing darkness can be set within 10-100%.

- **【Paragraph】**

**Spacing:** Distance between words, you can enter 0-100, one decimal place

**Leading:** The distance between two lines. Input range is limited depending on the canvas

**Text Alignment Way:**

Left Align	Align multiple lines to the left
Middle Align	Multiple lines align centered
Right Align	Align multiple lines to the right
Full Align	Align multiple lines around

- **【Name】**

It can be set to Chinese, English, numbers and symbols; cannot exceed 30 characters, empty and rename with added object are not allowed.

#### 4.2.4.6 Barcode object (Add Barcode object in simple mode)

- **【Message】 > 【New】 > 【Object List】 > 【Add】 > 【Barcode】**

---

- **【Input】** : Enter barcode text content.

- **【Type】** :



**Genre:** Select 1Dbarcode, 2D barcode.

**Type:** Select barcode type.

- **【 Specification 】**:  Note: 1D and 2D barcodes have different settings, user need to select barcode genre firstly.

Barcode type	Settings
Genre/GSI 1D Barcode	<b>Width:</b> Totally 1-16 levels to choose from. <b>Height:</b> Within the canvas size,1-12.7mm <b>Font:</b> Select barcode text font <b>Font Size:</b> Select barcode text font size. <b>Text Display:</b> User can switch from on or off. <b>Cut Edge:</b> Select barcode whether with white lace <b>Blank Level:</b> 0-4 grades to switch.
Genre/GSI 2D Barcode	<b>Width:</b> Totally 1-16 levels to choose from. <b>Error Correction Level:</b> QR code, 1-4 grades; PDF417, 1-7 grades. <b>Blank Level:</b> 0-4 grades to switch. <b>Size:</b> QR/DATAMATRIX bar code size specifications.

- **【Position】**

**X axis coordinates:** Input range -10-3000mm, you can click buttons   to adjust slightly.

**Y axis coordinates:** Input range according to canvas amount limited, also can click buttons 

 to adjust slightly.

- **【Zoom】**

**Width:** You can enter 10% to 300%, the greater value, the larger width font.

**Height:** You can enter 10% to 300%, the greater value, the higher font.

---

**Lock scale:** The proportion of barcode height and width. After select this function, when modify the font width or height, the font will be proportionally adjusted.



Tips: If the data location beyond the canvas, it will turn yellow, after saving only the content within the canvas can be printed.

- **【Other】**

**Rotation:** Input range 0-359, also can click buttons to adjust.

**Mirror:** There are None, Horizontal mirror, Vertical mirror three options, click the drop-down button to expand

- **【Name】**

It can be set to Chinese, English, numbers and symbols; cannot exceed 30 characters, empty and rename with added object are not allowed.

#### 4.2.4.7 Logo object (Refer to the video “Add logo object in simple mode”)

- **【Message】 > 【New】 > 【Object List】 > 【Add】 > 【Logo】**

- **【Picture Setting】** : Select from the picture list

- **【Position】**

**X axis coordinates:** Input range -10-3000mm, you can click buttons to adjust slightly.

**Y axis coordinates:** Input range according to canvas amount limited, also can click buttons to adjust slightly.



- **【Zoom】**

**Width:** You can enter 10% to 300%, the greater value, the larger width pic

**Height:** You can enter 10% to 300%, the greater value, the higher pic.

**Lock scale:** The proportion of pic height and width. After select this function, when modify the font width or height, the font will be proportionally adjusted.

- **【Other】**

**Rotation:** Input range 0-359, also can click buttons   to adjust.

**Mirror:** There are None, Horizontal mirror, Vertical mirror three options, click the drop-down button to expand

- **【Name】**

It can be set to Chinese, English, numbers and symbols; cannot exceed 30 characters, empty and rename with added object are not allowed.

---

## 4.2.5 Edit Message

- Click **【Message】** from the main interface, then click **【List】** to see all the messages added.
- Select the message, and click **【Edit】**
- After editing, click return, choose save or not.

 **Tips:** When the MSG with dynamic source (Counter, Device Info, Date Time, Scan, Shift) has print records, edit this MSG and save it, will prompt to **【Save】** **【Not Save】** **【Save As】** **【Cancel】** options. Select **【Save As】** to retain the original MSG, and create a new MSG. Select **【Save】**, the original MSG will be covered, the print records is cleared and cannot be reprinted.

## 4.2.6 Copy/Paste Message

Select the message in list, click **【Copy】**, and then click any position in the list, click **【Paste】**, the message will be copied and named as the original one with “C1” at the end. For example, if original message is MSG001, the copied one will be named as “MSG001C1”.

- Can do multiple choice, copy and paste them at the same time.
- If copied several times, only the last copied message(s) will be pasted.

## 4.2.7 Delete Message

Select the message(s) in the list, click **【Delete】**, yes to delete or no to cancel.

# 4.3 Printing Management

## 4.3.1 Start/Stop Printing

- **【Print】** > **【List】**, refer to [List Function](#)
- Select the message, and click **【Start】**
- After start printing, printing report will pop up, **【Start】** button change to **【Stop】**, then after get the sensor signal, message will be printed.
- Click **【Stop】**, printing report will disappear, button will go back to **【Start】**.
- After opening the jet printing, you can switch other data, click again to start the jet printing, prompt “stop current message printing and star print XXX?”; Select OK, automatically stop printing current data; Select NO, continue printing current data.

---

### 4.3.2 Printing Report Display

- While printing is on, user will see the below information from the printing report:

**Left:** Message name, counter, system time.

**Middle:** Dynamic source content in printing (only when counter, shift, dynamic text included in the message).

**Right:** Scan content, next printing content (only display while printing scanning information.)

- Report content changes according to real time printing status.
- Click the top arrow will hide the report, click again will display.

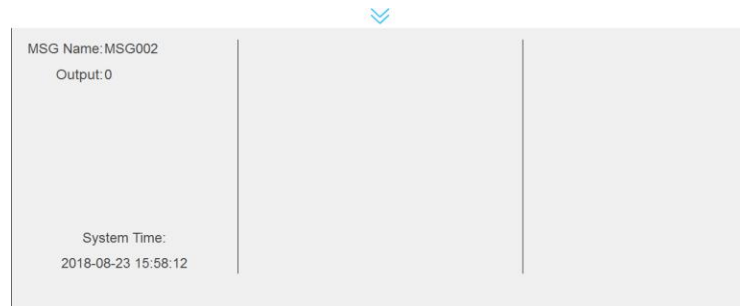

### 4.3.3 Printing Delay

Printing Delay: It is the distance from the point when photocell senses the printing object to the point when printing starts. User can adjust the value to alter the print position on printing object.

- **【Print】 > 【Delay】**
- Value within 0-1000mm, down to the first decimal point. Click **【Yes】**, save the setting and go back to previous menu, or click **【Cancel】** to quit without saving.
- Setting modification will be valid from next printing message.
- Delay value also can be set after printing started.

### 4.3.4 Initial Setting

 Note: This function only valid while message contains counter /text source. After printing started, this setting is not settable. After start to print, the key of **【Start】** is hidden.

- **【Print】 > 【Initial】**

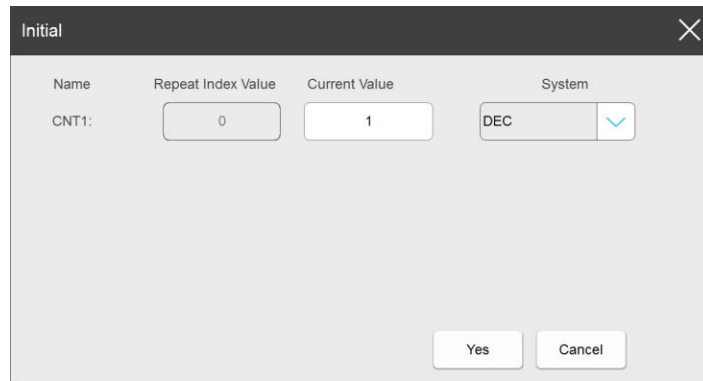

- Set the current value, index value of counter.

**Current Value:** the value will be printed after start printing, value need to be within the begin value and end value.

**System:** User can choose the system in the pull-down menu.

**Repeat Index Value:** The next printing is the Nth time of the repeat value. The repeat value of counter source need to be nonzero.

- Set the text source, can modify the text content, the next printing content will be changed after saving the settings.

- After setting the current value, click【Yes】to save, valid from next printing, or click 【Cancel】to exit.

### 4.3.5 Printing Monitor

After start printing of a message which contains dynamic source (counter , scan, shift, date time, device info, shift), click 【Monitor】 to check printing data and coming data.

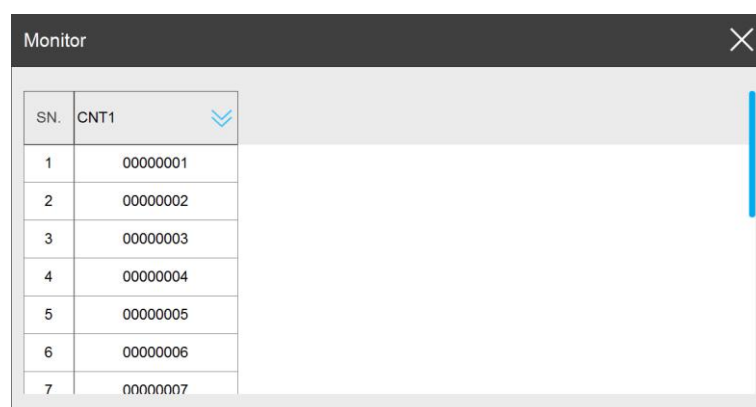

- Dynamic source information will be displayed by sequence, user may pull down the menu to check if data quantity more than 5pcs.

- The display sequence can be manually selected: click 【Pull down】 , select the data.

- Click 【Off】 , will close the monitor.

- Monitor information has a real time updating.
- The print monitor list display is determined by the print cache. For example, if print cache is set to 10, the list of monitor shows 10 records.

### 4.3.6 Re-print

 **Tips:** Reprint is invalid if the message without dynamic source (counter, scan, shift, date time, device info).

Reprint function is available only when the message with the dynamic source is printed at least once.

- **【Message】 > 【Reprint】**
- Start/Stop printing, click **【Reprint】** to reprint the last message.
- Long press the button **【Reprint】** , go to the reprint interface.

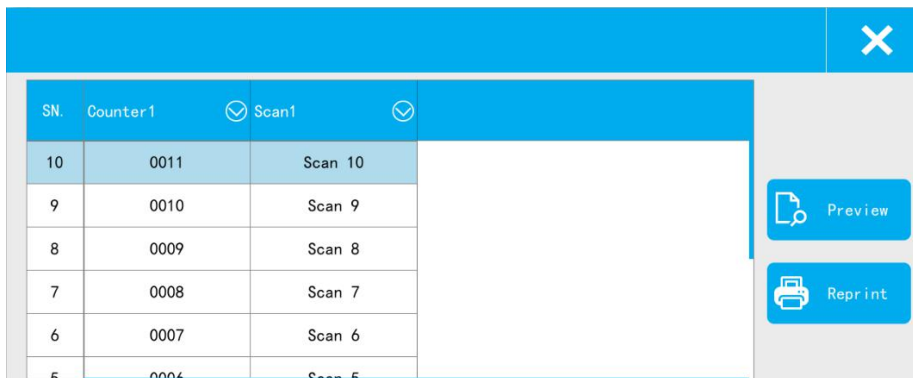

- Select the records you want to reprint in the list, click **【Reprint】** , can print the selected records.
- Select the record in the list, click **【Preview】** button, can preview the selected record.

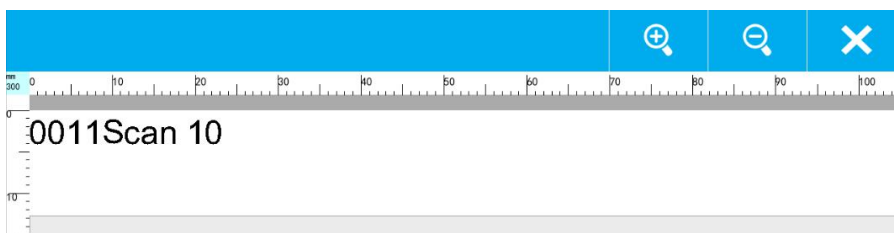

## 4.4 Print Parameter

### 4.4.1 Print Setting

**Print Direction:** set the printing direction of the printhead: L To R (from left to right), and R To L (from right to left).

**DPI:** Printing resolution, range from 50-600.

---

## 4.4.2 Printhead Setting

**Nozzle switch:** Two lines of nozzles of each printhead (left, right); user can select to use left/right/double nozzle(s). (Note: use single channel will save half ink drops, so the darkness will be lighter).

**Pre-purge:** When Pre-purge function is ON, printer will spray a little ink at optioned level during idle period in printing process to keep nozzle plate warm and moist so as to eliminate dried ink phenomenon. Five levels to choose from: Close, Low, Middle, High, and Custom.

- Default setting is Close.
- While setting is low, middle or high, pre-purge parameters will be set automatically according to the ink type.
- While setting is Custom, user can set the interval from 1 to 3600. For example, input 10 seconds, after start the printing and before sensor signal, every 10 seconds printer will spit some ink drops to make nozzles wet.

**Mode:** idle inkjet mode can select working nozzle, double nozzle

## 4.4.3 Printing Option

**Output Counter:** numbers already printed. After being modified, counter will run based on the new value.

**Counter Reset:** Every time user print a message which contains a counter, system will ask if to reset the counter after this printing, if select “Yes”, then from next printing counter will run from the minimum value, if select “No”, counter will continue from current value.

**Print Cache:** Message quantity saved in system memory, value can be 1-20, if set to 1, will print by real time.

**Blank Line No Print:** Message contains empty lines, open the blank line no print function, No printing blank line.

**Clear Cache:** Clear the cache and click on the button to clear the cache data in the device.

**Refresh Frequency:** Spray printing management preview interface automatically refresh display content according to the setting time.

## 4.4.4 Special Printing (Refer to the video “Continuous printing”)

**Continuous printing:** Continuous printing numbers, range from 0-9999, 0 means OFF, 9999 means unlimited; If set value to N(within 1-9998), then after get one sensor signal, N pieces messages will be

---

printed.

**Printing Interval:** The distance from the beginning of the first message to the beginning of the second message. Default value is 0mm, range from 0-9999.99mm.

**Long Term Induction of Electric Eye:** Start, it is necessary to continuously induce the electric eye to continuously print; Stop, induction one time can be continuous printing.

**Continuous Inkjet Switch:** Continuous printing parameters can only be set after opening.

## 4.5 System setting

### 4.5.1 System management

**System time:**

Year	Month	Day	Hour	Min	Second
2001-2999	1-12	1-31	0-23	0-59	0-59

**Unit:** 【mm or inch】 click the icon to select unit.

**Language:** 【English and others】 . Click the icon to select language.

- Default language: English How to upgrade other language, please refer to [How to upgrade language, fonts and input method](#)

- After switching language, printer will restart automatically.

**Device name:** Allow 30 characters. When message contains device name source, the message will change after the device name is changed.

**Screensavers:** System default 3 min, 5 options for changeover: 1 min, 3 min, 5 min, 30 min, OFF. If screen saver is optioned OFF, screen enters standby status if inactive for the set time. Screen becomes active when there's alarm or error.

**Screen brightness:** User can set the brightness from 10-100%, default is 30%.

**Message Mode:** Select message management mode, standard mode or simple mode.

### 4.5.2 User management (Refer to the video “User management”)

It allows administrator to assign rights of operation.

**Open user management feature**

- **【System】 > 【User management】**
- Default status is closed, click the icon and it will jump out a page to input the password. The default password is 888888. Click “√” to open and click “×” to close.
- After successful opening, the interface jumps out of the user list, can carry out this operations **【 New User】 【Edit User】 【Change Password】 【Delete】** .

### Create new user

- After opening user management feature, click **【New】** to create new user.

The screenshot shows a 'User Edit' dialog box with a dark header and a close button (X) in the top right. On the left, there are two tabs: 'User' (selected) and 'Permission'. The main area contains three input fields: 'Username', 'Password', and 'Confirm'. A 'Yes' button is located at the bottom right of the dialog.

### Create user info

- User name: No more than 30 characters, cannot be empty.
- Password: No more than 16 digits.
- Confirm password: Should be the same as previous one.

The screenshot shows the 'User Edit' dialog box with the 'Permission' tab selected. The 'User' tab is also visible. The main area displays a grid of permissions: 'Print', 'Parameters', 'Message', 'Settings', and 'Tools' in a top row; 'Start/Stop', 'Delay', 'Initial', and 'Monitor' in the second row; and 'Reprint' in the third row. Each permission has a radio button next to it. At the bottom, there are five buttons for role selection: 'Operator', 'Technician', 'All', 'None', and 'Yes'.

### Create new user Rights

- Click **【Permission】** to get into new user rights setting page.
- It has 6 rights for new users.

Items	Features available
Print	Start/stop printing, Printing delay, Initial, Printing Monitor, and Reprint
Parameter	Direction, Nozzle, DPI, Output, Pre-purge, Counter reset, Cache, Special、 Blank line no print, CleanCache, Refreshrate,
Message	New message, Edit message, Copy, Paste, Delete
Setting	Setting, User control, About
Tools	Image, Upgrade, Backup /Restore, Permission, and Plugin Management
Operator	<b>【Print】</b> : All <b>【Setting】</b> : User control and About
Technician	<b>【Print】</b> : All; <b>【Parameter】</b> : All, <b>【Message】</b> : All; <b>【Setting】</b> : User control and About.



Tips:

- Select multiple options is available, repeat select will delete selected option.
- **【System reset】** feature in **【System】** is only allowed to be modified by administrator.
- **【User control】** by new user can only do its own password change, cannot do anything else.
- Click **【Operator】** , can select its rights(See operator power list above)
- Click **【Technician】** , can select its rights(See technician power list above)
- Click **【All】** , can select all rights.
- Click **【None】** , cancel all rights.

- 
- After setting new user info and rights, please click “ **【Yes】** ”to save.
  - After saving, new user info will be displayed in the list.

### **Edit user info and rights**

Open user management, select the user info you want to edit (Administrator not included), click **【Edit】** and do the edit and save.

### **Change user password**

Open user management, select the user info you want to edit and click **【Password】** to change password.



Tip: After logging user management, it can only change current user password.

### **Delete user info**

Open the user management, select user info and click **【Delete】** to delete user info.



Tip: Cannot delete Administrator.

### **Close user management**

Open user management, it will jump out a page requiring to input password, after inputting correct administrator password, and click **【OK】** ,the icon will turn grey to close user management.

### **Log in /Log out**

- Open user management, , it will jump out a page. Inputting the correct user name and password to log in.
- Open the user management, every time opening the printer, it requires to log in first.
- Close the user management, click cancel key device to enter screen saver status, can click on the screen to activate the device.

**Note:** Only in the main interface, click the logout button, you can click switch between different users, otherwise you can only login to the original user.

## **4.5.3 System Reset (Refer to the video “System Reset”)**

If required to restore back to factory setting, you can do system reset.

- **【System】** > **【System Reset】**

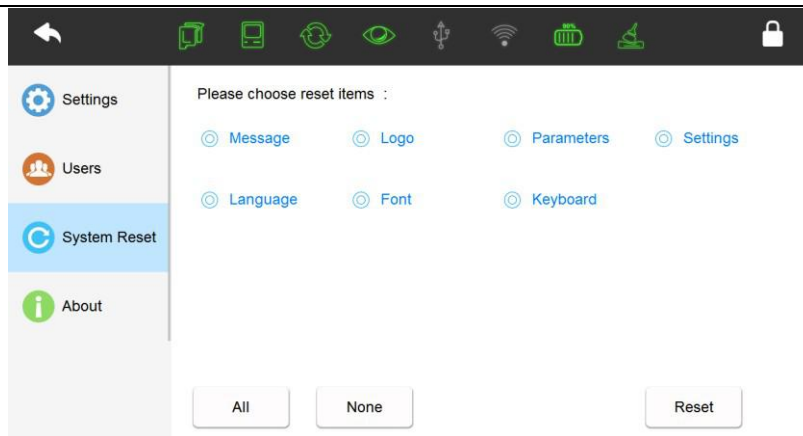

- Click **【All】** , all options are selected automatically.
- Click **【None】** , all selected options are deleted.
- After selected, click **【Reset】** , it will jump out a page requiring to input administrator password. Then the printer will restart automatically.

Items can be reset:

Module	Items	Parameters
Message	Message list	Clear
Image	Image list	Clear
Printing parameters	Printing direction	R To L
	Nozzle switch	Left nozzle
	DPI	300
	Mirror	None
	Production counter	0
	Spit function	Closed
	Counter reset	Closed
	Printing buffer	20
	Blank Line No Print	Closed
	Clear Cache	Closed
	Continuous printing	0
	Refresh Rate	0
Printing gap	1	
System parameter	System time	Default time
	Unit	mm
	Device name	INKJET
	Screensavers	3mins
	Screen brightness	30
	Message Mode	Standard Mode
	User control	Closed
Language	Language management	English

Font	Font management	default
Input	Input management	English

## 4.5.4 About

【System】 > 【About】

Display company name, website, company logo, software version, hardware version, device SN, and customer code.

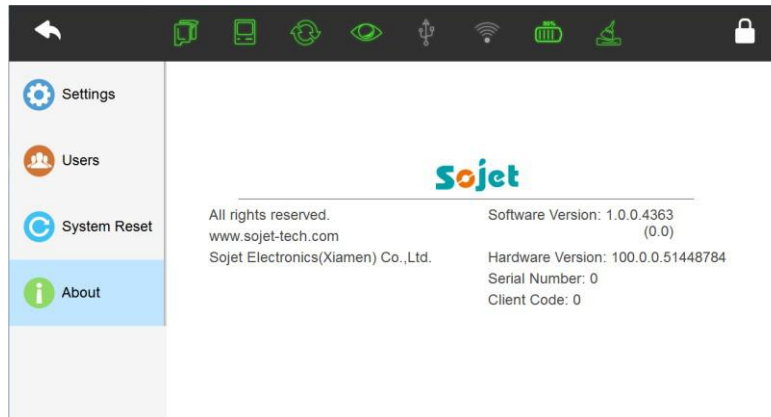

## 4.6 Tools

### 4.6.1 How to manage local images

【Tools】 > 【Logo】

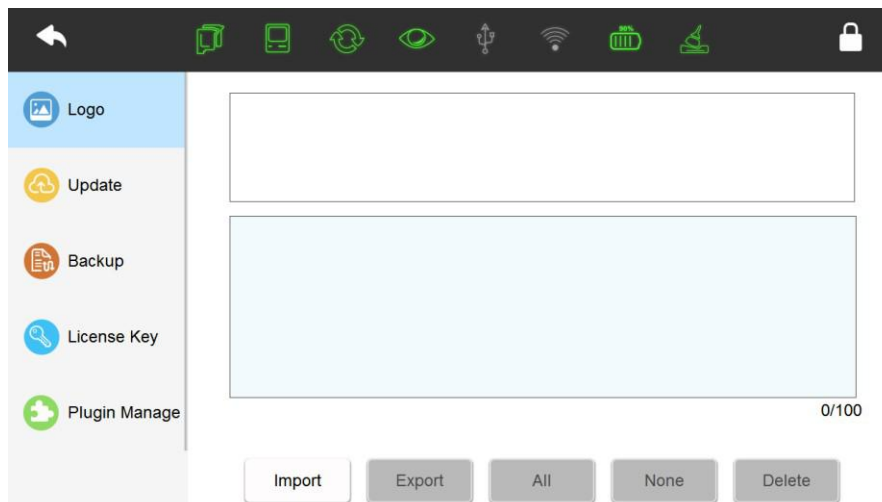

#### Preview image

Select images and it will show images for preview.

#### Import images (Refer to the video “import and export images”)

- Insert USB with images, click 【Import】 to import images.
- If pixels are more than 150\*10000, it will import failure.

- 100 images maximum.
- Import picture format: bmp/jpg/png/gif

### **Export images (Refer to the video “import and export images”)**

Insert USB and click **【Export】** to export images, the default path is ( Inkjet/Logo/ )

### **Delete images**

Select images and click **【Delete】** to delete images.

### **All selected**

Click **【All】** to select all.

### **Cancel selection**

Click **【None】** to cancel selection.

## **4.6.2 How to upgrade language/font/typewriting**

**【Tools】 > 【Upgrade】**

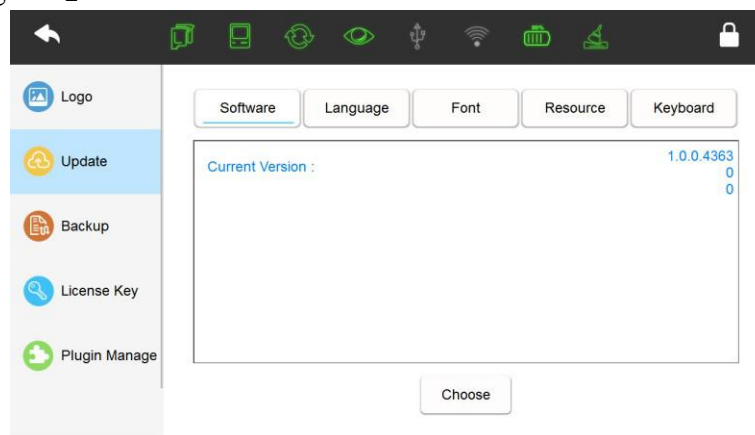

### **Upgrade language (Refer to the video “Upgrade language”)**

- Insert USB with language file (File stores in USB under: Inkjet\Upgrade\Language)
- Click **【 Language 】** to select language, the list shows the upgraded language, the default is only English.
- Click **【Choose】** , After upgrading from the U disk path, you can choose the upgrade language in the **【system management】 【language】**

- Can upgrade 3 different languages. Click **【Delete】** to delete language.

### **Upgrade font (Refer to the video “Upgrade font”)**

- Insert USB with font file (File stores in USB under: Inkjet\Upgrade\Font)
- Click **【Font】** to select font, the list shows the upgraded font, default is the base.
- Click **【Choose】** , After upgrading from the U disk path, you can choose the upgrade language in the

## 【System Management】 【Language】

- Can upgrade 3 fonts, click 【Delete】 to delete font

### Upgrade Input method (Refer to the video “Upgrade Input method”)

- Insert USB with font file (File stores in USB under: Inkjet\Upgrade\Keyboard\)
- Click 【 Input 】 to select input method, the list shows the upgraded input method, the default is English.
- Click 【 Upgrade 】 to select input method from USB to upgrade and after upgrade, the printer will restart.
- Can upgrade 3 input methods, click 【Delete】 to delete.

### Upgrade Resource Pack

- Insert USB with font file (File stores in USB under: Inkjet\Upgrade\Keyboard\)
- Click 【Resource】 ,jump the resource pack list to display the upgraded resource package.
- Click 【Choose】 , jump out of U disk path, select upgrade package to upgrade.

## 4.6.3 Permission



Some features need to be registered before use.

【Tools】 > 【License Key】

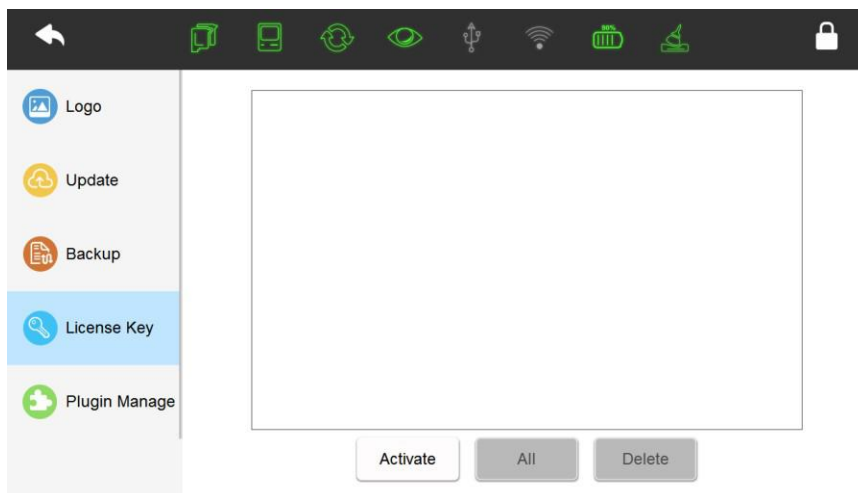

### Register

Insert USB with registration file, click 【Activate】 to select file to do registration.



Precaution:

- Can register more features in one printer.
- If registration code is expired, the registration icon will disappear and you need to do registration

again.

### Select All

- Click **【Select All】** , all features in the list are checked, can be deleted.

### Delete registration

- Click **【Delete】** to delete registration.

## 4.6.4 Plugin Management (Refer to the video “Plugin Management”)

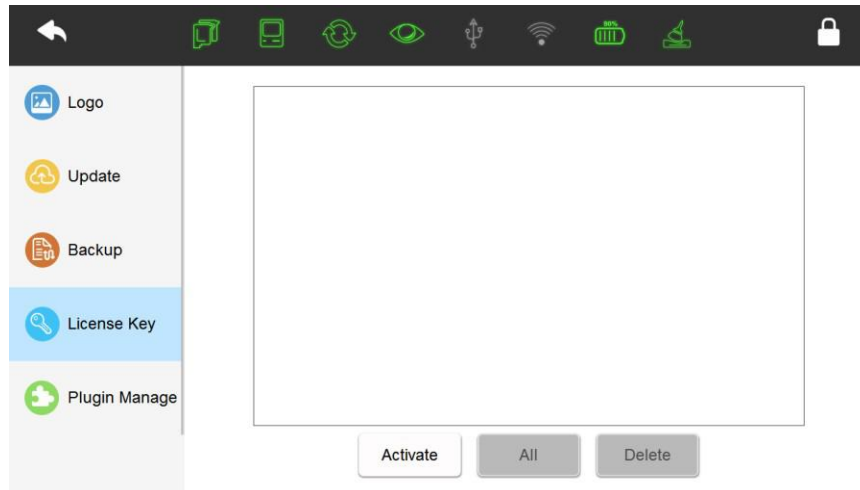

• Insert USB with plug-in file, click **【Add】** to select file to add plugin, after add plugin successfully, shows in the list.

- Click **【Select All】** , all plugins in the list are checked.
- Click **【Delete】** to delete the selectable plugin in the list.

## 4.7 Status bar

### 4.7.1 Cartridge status



Click  to display cartridge status.

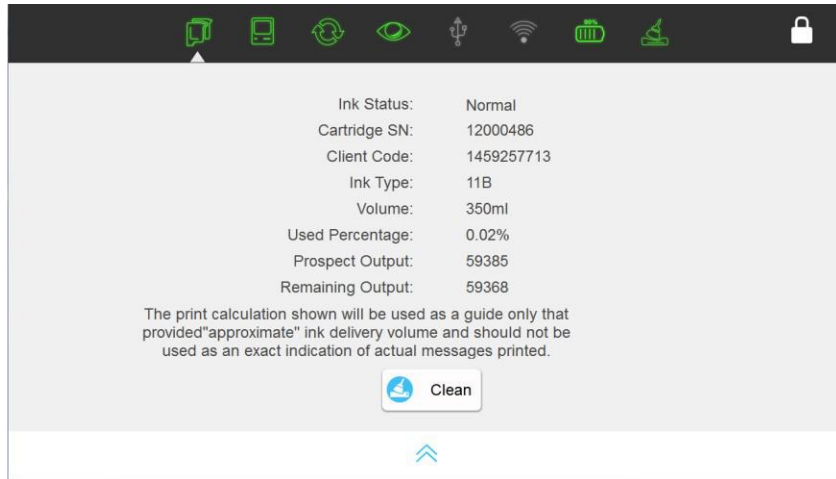

### Cartridge icon color

Grey: No cartridge

Green: Normal

Orange: Ink ran up to 95%--warning

Red: Empty cartridge or error cartridge

### Display cartridge info

Ink status, Cartridge SN, Client Code, Ink type, Volume, Used percentage, Data points

### Clean printhead

Click **【Clean】** to clean printhead when it is not printing.

## 4.7.2 System status

Click  to display system status

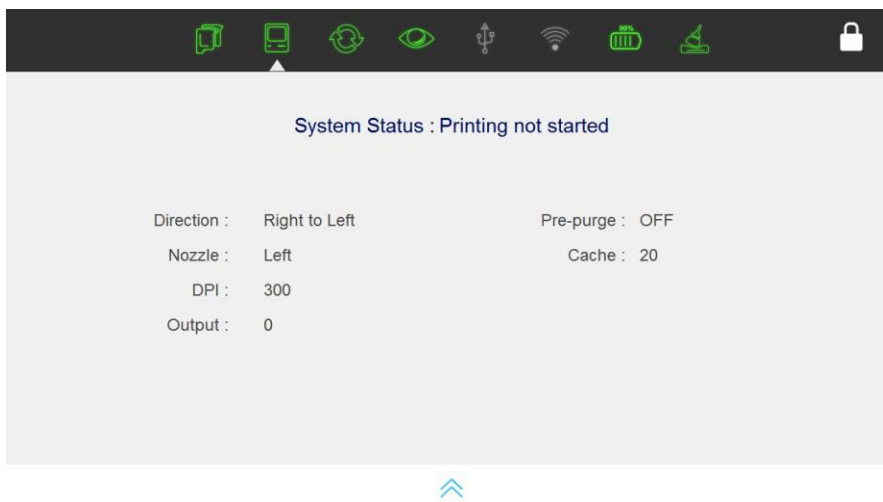

---

## System status color

Green: Normal

Red: System time reset, FPGA error, etc.

## Display system info

System status, Printing State, MSG name, Direction, Print nozzle switch, DPI, Output, Pre-purge, Print cache, Times (Continuous printing), Interval, and Mirror.

System Error: Display system error information, error code.

### 4.7.3 Encoder information (Refer to the video “Encoder Test”)

Displays encoder connection status, when encoder is connected, click  icon, encoder signal test interface appears.

### 4.7.4 Photocell information (Refer to the video “Photocell Test”)

Displays photocell connection status, when photocell is connected, click  icon, encoder signal test interface appears.

Currents Status: Press the print switch, the current status shows OPEN, release the print switch, the current status shows OFF.

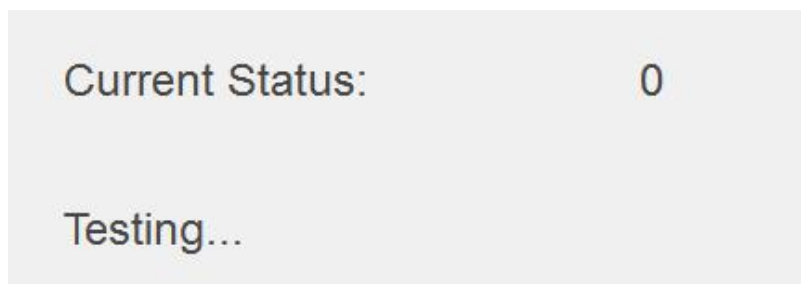

### 4.7.5 USB Status

- After USB inserted, click  to display USB status.

USB info: USB volume, USB space occupied, USB space remained.

---

## 4.7.6 Battery Indicator



Green: The remaining power is 20%-100%



Yellow: The remaining power is 10%-20%



Red: Low battery, it means the battery is less than 10%



Precaution: when battery is low, please recharge ASAP.

## 4.7.7 WI-FI Status

Display WI-FI connection status as  (gray) and normally  (green).

- Click  Wi-Fi interface appears (Default is turn off, and the list is empty).

- Turn on WLAN, scan Wi-Fi device automatically and display the scan results in the list.

- Clip the switch and turn on, the system will search the network automatically, and display in the list;

You also can manually click **【Search】** button to find the network.

- Click a Wi-Fi device, pop-up password input box, enter the correct password to connect to the wireless network. (Note: Click a no password WI-FI can be connected automatically.)

## 4.7.8 Log out

Please refer to [Log in /Log out](#).

## 4.8 Input Method Introduction

On the keyboard, user can input capital letter, lowercase letter, numbers, common symbols, Chinese, Spanish.

Lowercase letter: default keyboard is lowercase letters, displayed as below:

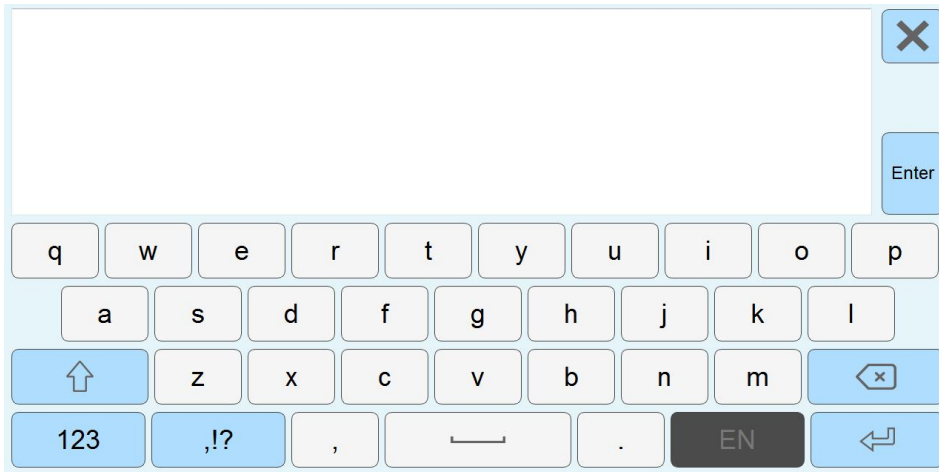

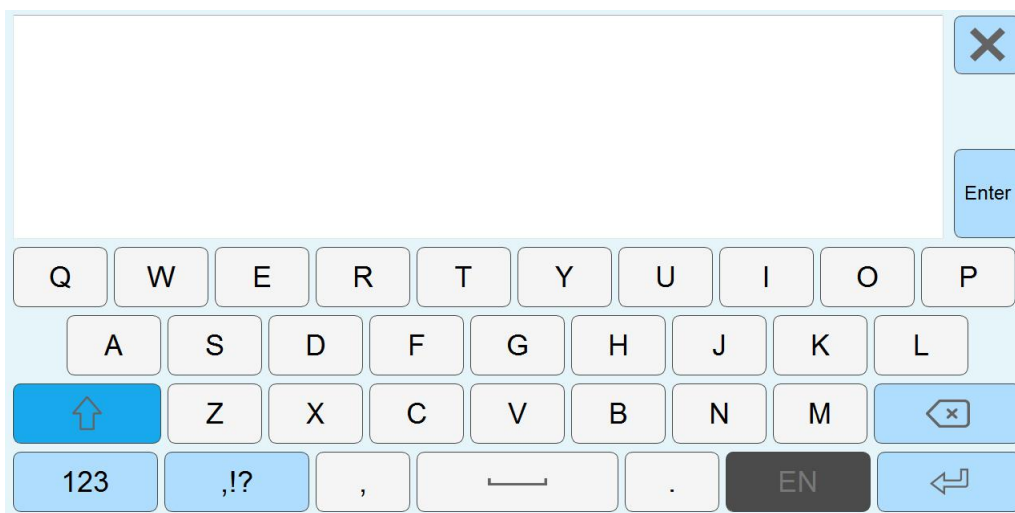

Capital letter: shift by 



Numbers: shift by 

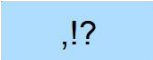

Symbols: click  to shift to symbols; click  shift to Chinese symbols.

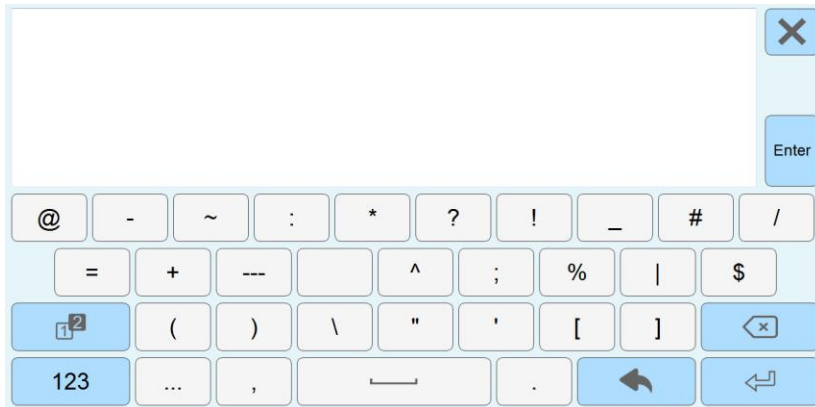



Chinese: Click   to shift from Chinese and English; Chinese typing only workable while system language is Chinese.



Spanish: Change the system language to Spanish, long-press a,e, i, o, u, n, system will pop-up the corresponding symbols.

 **【Cancel】** close keyboard, quit without save

 **【Enter】** close keyboard and save

 **【Delete】** delete the type, long-press will delete all the content in the input box.

 **【Newline】** input in next line.

## Appendix 1: Terms and Definition

SN	Term	Description	Remark
1	Print delay	To adjust the distance from the time when photocell detected the object till printing.	If set delay distance as 30mm, then it will start to print after 30mm later when photocell detect the object
2	Initial value	Initial value from printing	For example, if set initial value as 9, the first print value is 9
3	Time change	Users can set day switch time	When set day switch as "08:00" July 10, then the time is 07:59 July 09 for all printing before /on"07:59"
4	Pre-purge	To avoid printhead clogged	To avoid printhead clogged
5	Printhead cleaning	To clean printhead	To clean printhead
6	Nozzle switch	Switch nozzle to get better print result.	Switch nozzle to get better print result.
7	Continuous printing	Multi-printing during the time from photocell begins and ends	
8	Screen saver time	To shut down screen to save electricity power.	For example, if set screen saver time as 0.5H, if no more operation within 0.5H, the screen will be shut down.