

Huaxun testing (Shenzhen) Group Co., Ltd

Report No: E08230018-KY

EMC TEST REPORT

Applicant: Shenzhen KY Intelligent Digital Co., Ltd
Address: B1 Building 5th floor XuJingChang Industry zoom,
Fuhai road, Baoan, SZ. 518126
Manufacturer: Shenzhen KY Intelligent Digital Co., Ltd
Address: B1 Building 5th floor XuJingChang Industry zoom,
Fuhai road, Baoan, SZ. 518126
Product name: SMART WATCH
Model: X22
Serial model: X22 MAX
Brand Name : N/A
Sample Received Date: Aug. 16, 2024
Testing Period: Aug. 16, 2024~Aug. 23, 2024
Test Standard: ETSI EN301489-1V2.2.3(2019-11)
ETSI EN301489-17 V3.2.6(2023-06)
TEST FACTORY: Huaxun testing (Shenzhen) Group Co., Ltd
Goldman Sachs building, No. 18, Shaqi Community Center Road,
Xinqiao street, Bao'an District, Shenzhen, Guangdong, China

Test Requirement:

This device described above has been tested by Huaxun testing (Shenzhen) Group Co., Ltd., and the test results show that the equipment under test (EUT) is in compliance with the 2014/53/EU RED Directive Art.3.2 requirements. And it is applicable only to the tested sample identified in the report.

Prepared by:

Rite

Reviewer:

He di

Approved & Authorized Signer:

Spike



Huaxun testing (Shenzhen) Group Co., Ltd

Report No: E08230018-KY

Table of Contents	Page
1 TEST SUMMARY	3
2 GENERAL INFORMATION	6
2.1 GENERAL DESCRIPTION OF EUT	6
2.2 DESCRIPTION OF THE TEST MODES	7
2.3 DESCRIPTION OF TEST SETUP	7
2.4 DESCRIPTION TEST PERIPHERAL ANDEUT PERIPHERAL	8
2.5 MEASUREMENT INSTRUMENTS LIST	9
3 RADIATED EMISSIONS MEASUREMENT	12
3.1 RADIATION EMISSION LIMIT	12
3.2 TEST SETUP	12
3.3 TEST PROCEDURE	13
3.4 TEST RESULT	13
4 EMC IMMUNITY TEST	17
5 ELECTROSTATIC DISCHARGE IMMUNITY TEST (ESD)	19
5.1 TEST SPECIFICATION	19
5.2 TEST SETUP	19
5.3 TEST PROCEDURE	20
5.4 TEST RESULT	21
6 RADIATED, RADIO-FREQUENCY, ELECTROMAGNETIC FIELD IMMUNITY TEST (RS)	22
6.1 TEST SPECIFICATION	22
6.2 TEST SETUP	22
6.3 TEST PROCEDURE	23
6.4 TEST RESULT	24
7 PHOTO OF EUT	25

Huaxun testing (Shenzhen) Group Co., Ltd

Report No: E08230018-KY

1 TEST SUMMARY

TEST RESULTS

Test procedures according to the technical standards:

ETSI EN 301 489-1 V2.2.3 (2019-11)

ETSI EN 301 489-17 V3.2.6(2023-06)

EMC Emission				
Standard	Test Item	Limit	Judgment	Remark
EN 55032:2015/A11:2020	Conducted Emission On AC And Telecom Port 150kHz to 30MHz	Class B	N/A	
	Radiated Emission 30MHz to 1000MHz	Class B	PASS	
	Radiated Emission 1GHz to 6GHz	Class B	PASS	NOTE (1)
EN IEC 61000-3-2:2019	Harmonic Current Emission	—	N/A	NOTE (2)
EN 61000-3-3:2013/A1:20 19	Voltage Fluctuations & Flicker	—	N/A	
EMC Immunity				
Section EN 55035:2017/A11:2020	Test Item	Performan ce Criteria	Judgment	Remark
EN 61000-4-2:2009	Electrostatic Discharge	B	PASS	
EN 61000-4-3:2006 +A1:2008+A2:2010	RF Electromagnetic Field	A	PASS	
EN 61000-4-4:2012	Fast Transients	B	N/A	
EN 61000-4-5:2014 /A1:2017	Surges	B	N/A	
EN 61000-4-6:2014 /AC:2015	Injected Current	A	N/A	
EN 61000-4-8:2010	Power Frequency Magnetic Field	A	N/A	
EN IEC 61000-4-11:2020	Volt. Interruptions Volt. Dips	B / C / C	N/A	NOTE (3)

Huaxun testing (Shenzhen) Group Co., Ltd

Report No: E08230018-KY

Note:

- (1) If the highest frequency of the internal sources of the EUT is less than 108 MHz, the measurement shall only be made up to 1 GHz.
If the highest frequency of the internal sources of the EUT is between 108 MHz and 500 MHz, the measurement shall only be made up to 2 GHz.
If the highest frequency of the internal sources of the EUT is between 500 MHz and 1GHz, the measurement shall only be made up to 5 GHz.
If the highest frequency of the internal sources of the EUT is above 1 GHz, the measurement shall be made up to 5 times of the highest frequency or 6 GHz, whichever is less.
- (2) The power consumption of EUT is less than 75W and no Limits apply.
- (3) Voltage Dip: 100% reduction – Performance Criteria B
Voltage Dip: 30% reduction – Performance Criteria C
Voltage Interruption: 100% Interruption – Performance Criteria C
- (4) For client's request and manual description, the test will not be executed.
- (5) "N/A" denotes test is not applicable in this Test Report.



Huaxun testing (Shenzhen) Group Co., Ltd

Report No: E08230018-KY

MEASUREMENT UNCERTAINTY

The reported uncertainty of measurement $y \pm U$, where expanded uncertainty U is based on a standard uncertainty multiplied by a coverage factor of $k = 2$, providing a level of confidence of approximately 95%.

A. Conducted Measurement:

Test Site	Method	Measurement Frequency Range	U, (dB)	NOTE
HX	ANSI	9kHz ~ 150kHz	2.96	
		150kHz ~ 30MHz	2.44	

B. Radiated Measurement:

Test Site	Method	Measurement Frequency Range	U, (dB)	NOTE
HX	ANSI	9kHz ~ 30MHz	2.50	
		30MHz ~ 1000MHz	4.80	
		1000MHz ~ 6000MHz	4.13	

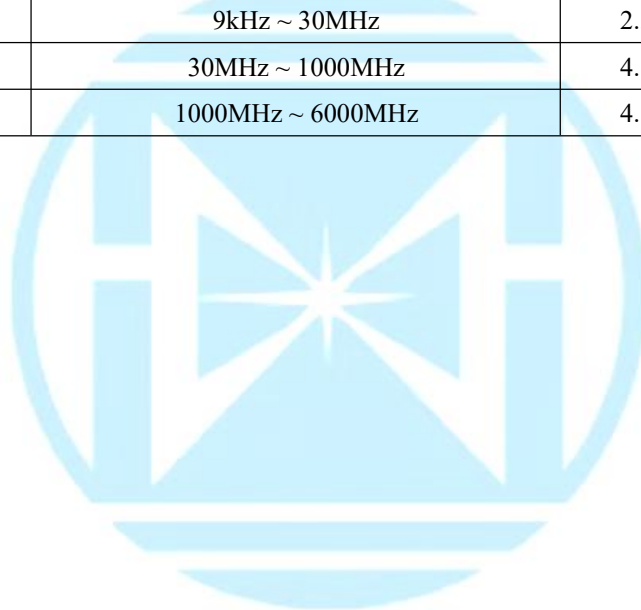

Huaxun testing (Shenzhen) Group Co., Ltd

Report No: E08230018-KY

2 GENERAL INFORMATION

2.1 GENERAL DESCRIPTION OF EUT

Product Name:	SMART WATCH
Brand Name :	N/A
Main Model:	X22
Additional Model:	X22 MAX
Model Difference:	All model's the function, software and electric circuit are the same, only with a product color and model named different.
Power Source:	Input: DC 5V, 160mA Battery: 3.8V, 330mAh, 1.25Wh Operating frequency: 2402-2480MHz
Product Description:	The EUT is a SMART WATCH. Based on the application, features, or specification exhibited in User's Manual, more details of EUT technical specification, please refer to the User's Manual.

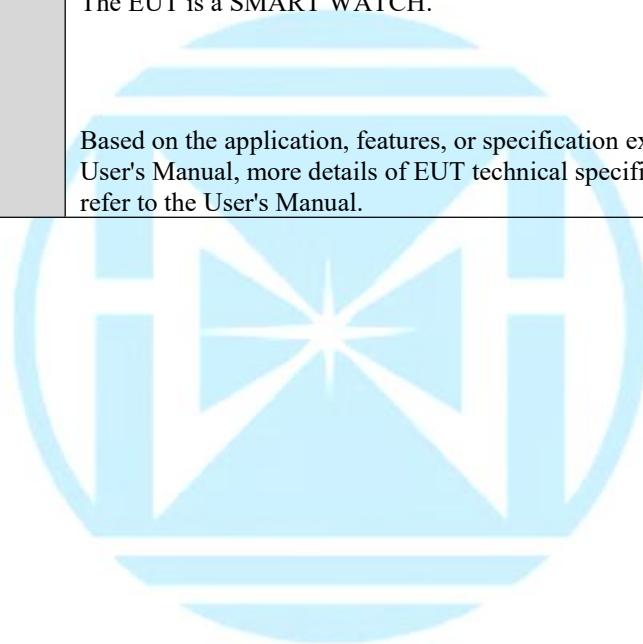

Huaxun testing (Shenzhen) Group Co., Ltd

Report No: E08230018-KY

2.2 DESCRIPTION OF THE TEST MODES

To investigate the maximum EMI emission characteristics generates from EUT, the test system was pre-scanning tested base on the consideration of following EUT operation mode or test configuration mode which possible have effect on EMI emission level. Each of these EUT operation mode(s) or test configuration mode(s) mentioned above was evaluated respectively.

Pretest Mode	Description
Mode 1	Running

For Radiated Test	
Pretest Mode	Description
Mode 1	Running

For EMS Test	
Pretest Mode	Description
Mode 1	Running

Note: The test modes were carried out for all operation modes (include link and idle).

2.3 DESCRIPTION OF TEST SETUP

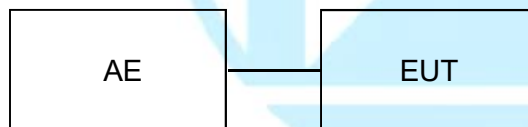

Note: The EUT tested system was configured as upper figure, unless otherwise a special operating condition is specified in the following during the testing.

Huaxun testing (Shenzhen) Group Co., Ltd

Report No: E08230018-KY

2.4 DESCRIPTION TEST PERIPHERAL AND EUT PERIPHERAL

The EUT has been tested as an independent unit together with other necessary accessories or support units. The following support units or accessories were used to form a representative test configuration during the tests.

Item	Equipment	Mfr/Brand	Model/Type No.	Note
E-1	SMART WATCH	N/A	X22	EUT

Item	Shielded Type	Ferrite Core	Length	Note

Note:

1. The support equipment was authorized by Declaration of Confirmation.
2. For detachable type I/O cable should be specified the length in cm in 『Length』 column.
3. “YES” is means “shielded” “with core”; “NO” is means “unshielded” “without core”

Huaxun testing (Shenzhen) Group Co., Ltd

Report No: E08230018-KY

2.5 MEASUREMENT INSTRUMENTS LIST

Item	Equipment	Manufacturer	Model No.	Serial No.	Calibrated until
Conduction Emissions Measurement					
1	Conducted Emission Test Software	EZ-EMC	Ver.CCS-3A1-CE	N/A	N/A
2	AMN	Schwarzbeck	NNLK8121	8121370	2024.10.15
3	AMN	ETS	3810/2	00020199	2024.10.15
4	AAN	TESEQ	T8-Cat6	38888	2024.10.15
5	Pulse Limiter	CYBRTEK	EM5010	E115010056	2025.05.20
6	EMI Test Receiver	Rohde&Schwarz	ESCI	101210	2024.10.15
Radiated Emissions Measurement					
1	Radiated Emission Test Software	EZ-EMC	Ver.CCS-03A1	N/A	N/A
2	Horn Antenna	Sunol	DMIETUBL-118	A101415	2024.10.18
3	Broadband Hybrid Antenna	Sunol	JB1	A090215	2025.03.01
4	PREAMP	HP	8449B	3008A00160	2024.10.21
5	PREAMP	HP	8447D	2944A07999	2025.05.20
6	EMI Test Receiver	Rohde&Schwarz	ESR3	101891	2024.10.15
7	MXA Signal Analyzer	Keysight	N9020A	MY51110104	2024.10.15
8	Active Loop Antenna	Com-Power	AL-310R	10160009	2025.05.20
9	Horn Antenna	Schwarzbeck	BBHA9120D	9120D-1680	2025.05.20
10	Horn Antenna	A-INFOMW	LB-180400-KF	J211060660	2024.10.23
11	Loop Antenna	Beijing daze Technology	ZN30401	13015	2024.10.15
12	EM Clamp	Schwarzbeck	MDS21	03350	2024.10.20
Harmonic / Flicker Measurement					
1	Power Analyzer	California Instrumnets	PACS-1	X71719	2024.10.15
2	AC Power Source	California Instrumnets	5001ix	HK53570	2024.10.15
Electrostatic Discharge Test					
1	ESD Generator	EVERFINE	EMS61000-2A	P185811371121	2024.10.17
RS Test					
1	Power Meter	Agilent	E4419B	QB4331226	2024.10.10
2	Power Sensor	Agilent	8481A	MY41092622	2024.10.10
3	Power Sensor	Agilent	8481A	US37296783	2024.10.10
4	Signal Generator	Agilent	N5182A	MY46240556	2024.10.10
5	Power Amplifier	MICOTOP	MPA-80-1000-250	1711489	2024.10.10

Huaxun testing (Shenzhen) Group Co., Ltd

Report No: E08230018-KY

6	Power Amplifier	MICOTOP	MPA-1000-3000-75	1711488	2024.10.10
7	Power Amplifier	MICOTOP	MPA-3000-6000-50	MPA1706275	2024.10.10
8	Bilog Antenna	TESEQ	CBL6111D	34678	2024.10.10
9	Horn Antenna	Schwarzbeck	BBHA9120D	9120D-1680	2024.10.10



Huaxun testing (Shenzhen) Group Co., Ltd

Report No: E08230018-KY

Item	Equipment	Manufacturer	Model No.	Serial No.	Calibrated until
Electrical Fast Transient / Burst Immunity Test					
1	EMS Test Control System	Shanghai Lioncel	SCU-614AS	SCU614S0160601	N/A
2	EFT/B Generator	Shanghai Lioncel	EFT-404S	EFT404S0160601	2024.10.10
Surge Test					
1	EMS Test Control System	Shanghai Lioncel	SCU-614AS	SCU614S0160601	N/A
2	Surge Generator	Shanghai Lioncel	LSG-506S	LSG506S0160601	2024.10.15
3	CDN	Shanghai Lioncel	CDN-532S	CDN532S0160601	2024.10.15
CS Test					
1	CS	SCHLODER	CDG-6000-25	126A1280/2014	2024.10.10
2	CDN	SCHLODER	CDN-M2+3	A2210275/2014	2024.10.10
3	EM Clamp	SCHLODER	EMCL-20	132A1283	2024.10.10
4	Attenuator	Nemtest	ATT-6DB-100	A100W224	2024.10.10
5	Audio Analyzer	R&S	UPL	100419	2024.10.10
6	Universal Radio Communication Tester	R&S	CMW500	117239	2024.10.10
7	Universal Radio Communication Tester	R&S	CMU200	111764	2024.10.10
8	Audio Analyzer	R&S	UPL	100689	2024.10.10
9	Audio Breakthrough Shielding Box	SKET	SB_ABT/C35	N/A	2024.10.10
10	Ear Simulator	SKET	AE_ABT/C35	N/A	2024.10.10
11	Mouth Simulator	SKET	AM_ABT/C35	N/A	2024.10.10
12	1KHz Standard Source	SKET	MSC_ABT/C35	N/A	2024.10.10
Power-frequency magnetic fields Test					
1	Magnetic Field Test System	Shanghai Lioncel	PMF801C-T	PMF801C-T0160701	2025.05.20
Voltage dips and interruptions Test					
1	Voltage SAG Simulator	Shanghai Lioncel	VDS-1101	VDS11010160601	2024.10.15
2	Adjustable Power Supply	Shanghai Lioncel	RGL-210	RGL2100151001	N/A

3 RADIATED EMISSIONS MEASUREMENT

3.1 RADIATION EMISSION LIMIT

Below 1000MHz:

Frequency (MHz)	Class A		Class B	
	10m	3m	10m	3m
	dBuV/m	dBuV/m	dBuV/m	dBuV/m
30~230	40	50	30	40
230~1000	47	57	37	47

Above 1000MHz:

Frequency (MHz)	Class A		Class B	
	PK	AV	PK	AV
	dBuV/m	dBuV/m	dBuV/m	dBuV/m
1000~3000	76	56	70	50
3000~6000	80	60	74	54

Note:

1. The tighter limit applies at the band edges.
2. Emission level (dBuV/m)=20log Emission level (uV/m).

3.2 TEST SETUP

1. Radiated Emission Test-Up Frequency Below 1000MHz

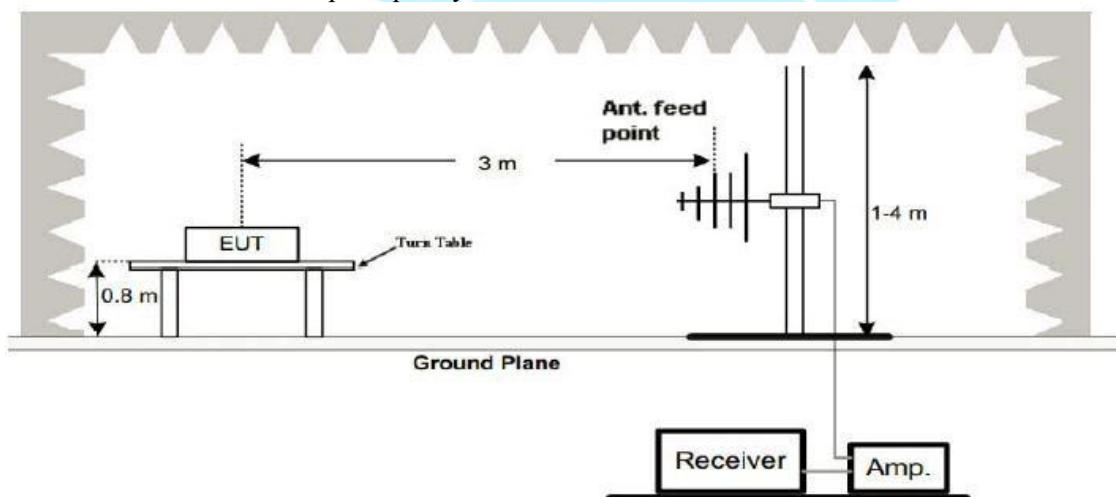

2. Radiated Emission Test-Up Frequency Above 1000MHz

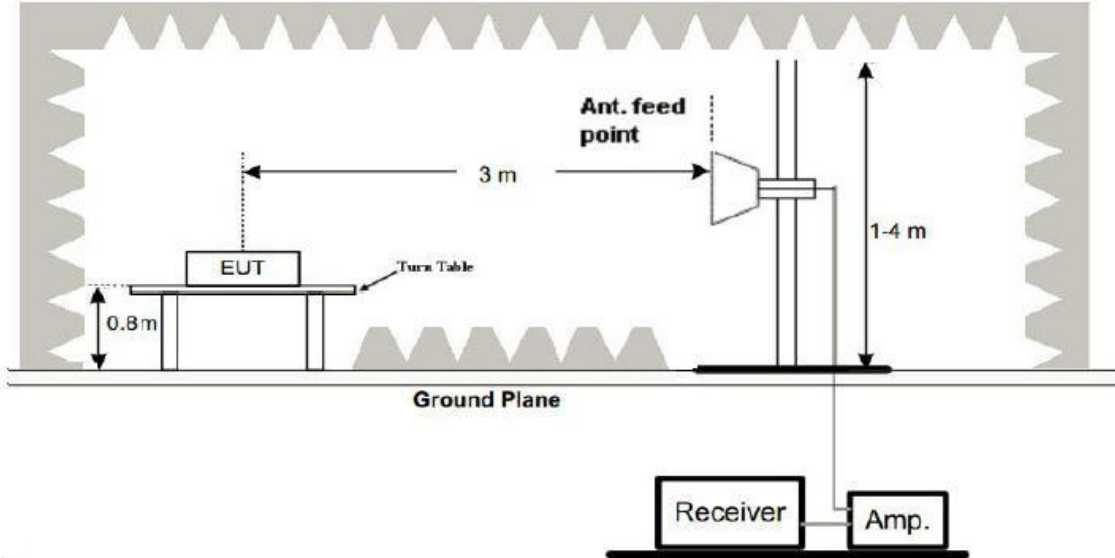

3.3 TEST PROCEDURE

1. The EUT was placed on the top of a rotating table 0.8 meters above the ground at a 3 meter semi-anechoic chamber room. The table was rotated 360 degrees to determine the position of the highest radiation.
2. The EUT was set 3 meters away from the interference-receiving antenna, which was mounted on the top of a variable-height antenna tower.
3. The height of antenna is varied from 1 meter to 4 meters above the ground to determine the maximum value of the field strength. Both horizontal and vertical polarizations of the antenna are set to make the measurement.
4. For each suspected emission, the EUT was arranged to its worst case and then the antenna was tuned to heights from 1 meter to 4 meters and the rotatable table was turned from 0 degrees to 360 degrees to find the maximum reading.
5. The test-receiver system was set to quasi-peak detect function and specified bandwidth with maximum hold mode when the test frequency is below 1GHz.
6. For the actual test configuration, please refer to the related Item EUT Test Photos.

3.4 TEST RESULT

PASS

Huaxun testing (Shenzhen) Group Co., Ltd

Report No: E08230018-KY

Below 1000MHz Test Results:

Temperature:	24°C	Relative Humidity:	48%
Test Voltage:	DC 5V	Pressure:	1010hPa
Test Mode:	Running	Polarization:	Horizontal



Suspected List									
NO.	Freq. [MHz]	Factor [dB]	Reading [dBµV/m]	Level [dBµV/m]	Limit [dBµV/m]	Margin [dB]	Height [cm]	Angle [°]	Polarity
1	41.651652	-17.03	27.12	10.09	40.00	29.91	100	9	Horizontal
2	59.129129	-18.18	29.73	11.55	40.00	28.45	100	297	Horizontal
3	155.25525	-16.86	33.92	17.06	40.00	22.94	100	345	Horizontal
4	308.66866	-17.25	31.52	14.27	47.00	32.73	100	43	Horizontal
5	604.81481	-11.16	29.90	18.74	47.00	28.26	100	295	Horizontal
6	769.87988	-8.10	33.30	25.20	47.00	21.80	100	64	Horizontal

Remark: Factor = Cable loss + Antenna factor – Preamplifier; Level = Reading + Factor; Margin = Limit – Level;

Huaxun testing (Shenzhen) Group Co., Ltd

Report No: E08230018-KY

Temperature:	24°C	Relative Humidity:	48%
Test Voltage:	DC 5V	Pressure:	1010hPa
Test Mode:	Running	Polarization:	Vertical

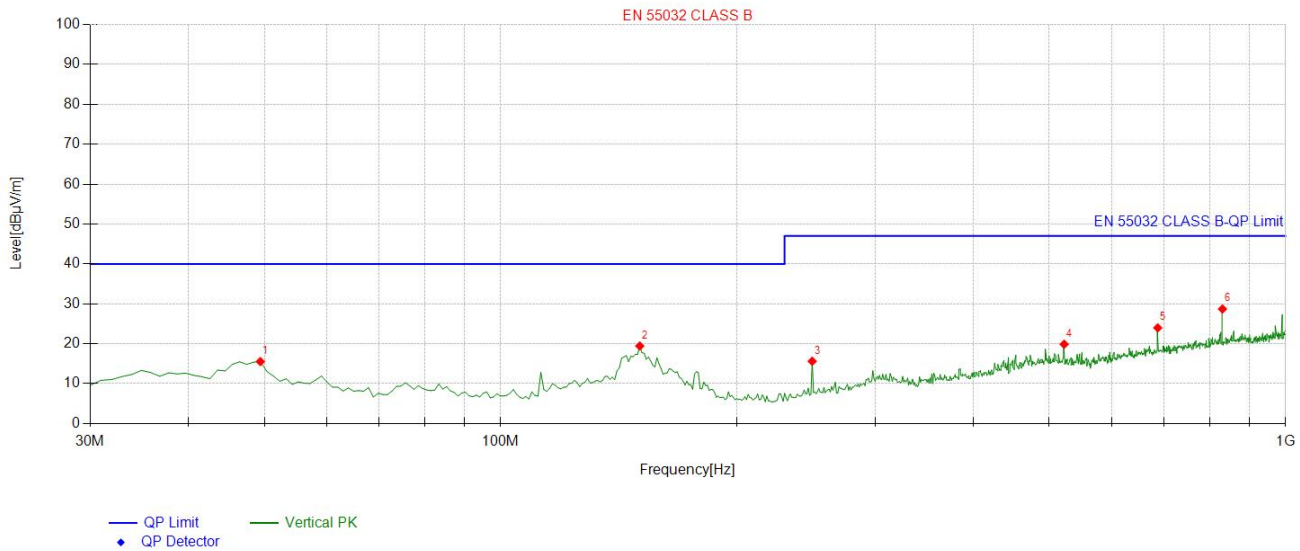

Suspected List

NO.	Freq. [MHz]	Factor [dB]	Reading [dBµV/m]	Level [dBµV/m]	Limit [dBµV/m]	Margin [dB]	Height [cm]	Angle [°]	Polarity
1	49.419419	-17.25	32.77	15.52	40.00	24.48	100	11	Vertical
2	150.4004	-17.26	36.69	19.43	40.00	20.57	100	76	Vertical
3	249.43943	-19.32	34.92	15.60	47.00	31.40	100	95	Vertical
4	522.28228	-12.83	32.70	19.87	47.00	27.13	100	172	Vertical
5	687.34734	-9.49	33.46	23.97	47.00	23.03	100	120	Vertical
6	831.05105	-7.34	36.04	28.70	47.00	18.30	100	111	Vertical

Remark: Factor = Cable loss + Antenna factor – Pre-amplifier; Level = Reading + Factor; Margin = Limit – Level;

Huaxun testing (Shenzhen) Group Co., Ltd

Report No: E08230018-KY

Above 1000MHz Test Results:

Note: The peak value is too low against the limit, so the test data is not record.



Huaxun testing (Shenzhen) Group Co., Ltd

Report No: E08230018-KY

4 EMC IMMUNITY TEST

GENERAL PERFORMANCE CRITERIA

According to ETSI EN 301 489 standard, the general performance criteria as following:

Criteria	During the test	After the test
A	Shall operate as intended. (see note 1). Shall be no loss of function. Shall be no unintentional transmissions.	Shall operate as intended Shall be no degradation of performance (see note 2) Shall be no loss of function Shall be no loss of stored data or user programmable functions
B	May show loss of function (one or more) May show degradation of performance (see note 1) No unintentional transmissions	Functions shall be self-recoverable Shall operate as intended after recovering Shall be no degradation of performance (see note 2) Shall be no loss of stored data or user programmable functions
C	May be loss of function (one or more)	Functions shall be recoverable by the operator Shall operate as intended after recovering Shall be no degradation of performance (see note 2)

NOTE 1: Operate as intended during the test allows a level of degradation not below a minimum performance level specified by the manufacturer for the use of the apparatus as intended. In some cases the specified minimum performance level may be replaced by a permissible degradation of performance. If the minimum performance level or the permissible performance degradation is not specified by the manufacturer then either of these may be derived from the product description and documentation (including leaflets and advertising) and what the user may reasonably expect from the apparatus if used as intended.

NOTE 2: Degradation of performance during the test is understood as a degradation to a level not below a minimum performance level specified by the manufacturer for the use of the apparatus as intended. In some cases the specified minimum performance level may be replaced by a permissible degradation of performance. If the minimum performance level or the permissible performance degradation is not specified by the manufacturer then either of these may be derived from the product description and documentation (including leaflets and advertising) and what the user may reasonably expect from the apparatus if used as intended.

NOTE 3: No degradation of performance after the test is understood as no degradation below a minimum performance level specified by the manufacturer for the use of the apparatus as intended. In some cases the specified minimum performance level may be replaced by a permissible degradation of performance. After the test no change of actual operating data or user retrievable data is allowed. If the minimum performance level or the permissible performance degradation is not specified by the manufacturer then either of these may be derived from the product description and documentation (including leaflets and advertising) and what the user may reasonably expect from the apparatus if used as intended.

Huaxun testing (Shenzhen) Group Co., Ltd

Report No: E08230018-KY

PERFORMANCE FOR TT

The performance criteria B shall apply, except for voltage dips of 100 ms and voltage interruptions of 5 000 ms duration, for which performance criteria C shall apply. Tests shall be repeated with the EUT in standby mode (if applicable) to ensure that unintentional transmission does not occur. In systems using acknowledgement signals, it is recognized that an acknowledgement (ACK) or not-acknowledgement (NACK) transmission may occur, and steps should be taken to ensure that any transmission resulting from the application of the test is correctly interpreted.

PERFORMANCE FOR TR

The performance criteria B shall apply, except for voltage dips of 100 ms and voltage interruptions of 5 000 ms duration for which performance criteria C shall apply. Where the EUT is a transceiver, under no circumstances, shall the transmitter operate unintentionally during the test. In systems using acknowledgement signals, it is recognized that an ACK or NACK transmission may occur, and steps should be taken to ensure that any transmission resulting from the application of the test is correctly interpreted.

PERFORMANCE FOR CT

The performance criteria A shall apply. Tests shall be repeated with the EUT in standby mode (if applicable) to ensure that unintentional transmission does not occur. In systems using acknowledgement signals, it is recognized that an Acknowledgement (ACK) or Not Acknowledgement (NACK) transmission may occur, and steps should be taken to ensure that any transmission resulting from the application of the test is correctly interpreted.

PERFORMANCE FOR CR

The performance criteria A shall apply. Where the EUT is a transceiver, under no circumstances, shall the transmitter operate unintentionally during the test. In systems using acknowledgement signals, it is recognized that an ACK or NACK transmission may occur, and steps should be taken to ensure that any transmission resulting from the application of the test is correctly interpreted.

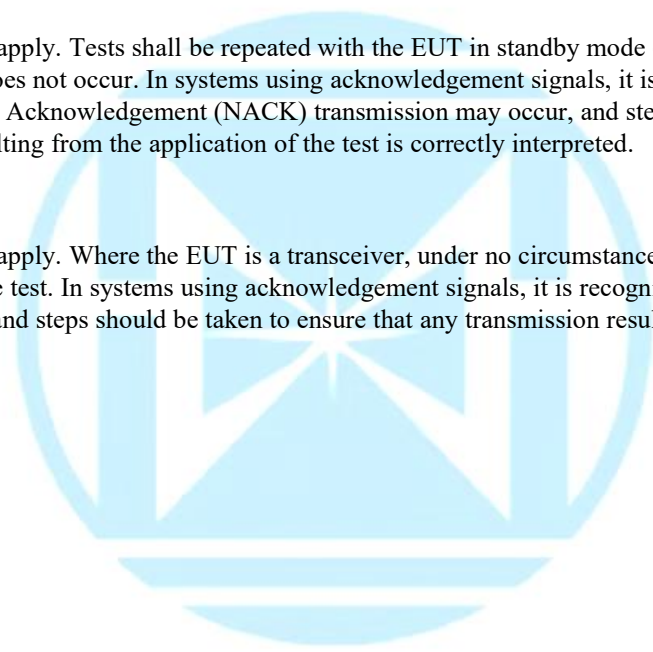

Huaxun testing (Shenzhen) Group Co., Ltd

Report No: E08230018-KY

5 ELECTROSTATIC DISCHARGE IMMUNITY TEST (ESD)

5.1 TEST SPECIFICATION

Basic Standard:	IEC/EN 61000-4-2
Discharge Impedance:	330 ohm / 150 pF
Required Performance:	B
Discharge Voltage:	Air Discharge: 2kV/4kV/8kV (Direct) Contact Discharge: 2kV/4kV (Direct/Indirect)
Polarity:	Positive & Negative
Number of Discharge:	Air Discharge: min. 20 times at each test point Contact Discharge: min. 200 times in total
Discharge Mode:	Single Discharge
Discharge Period:	1 second minimum

5.2 TEST SETUP

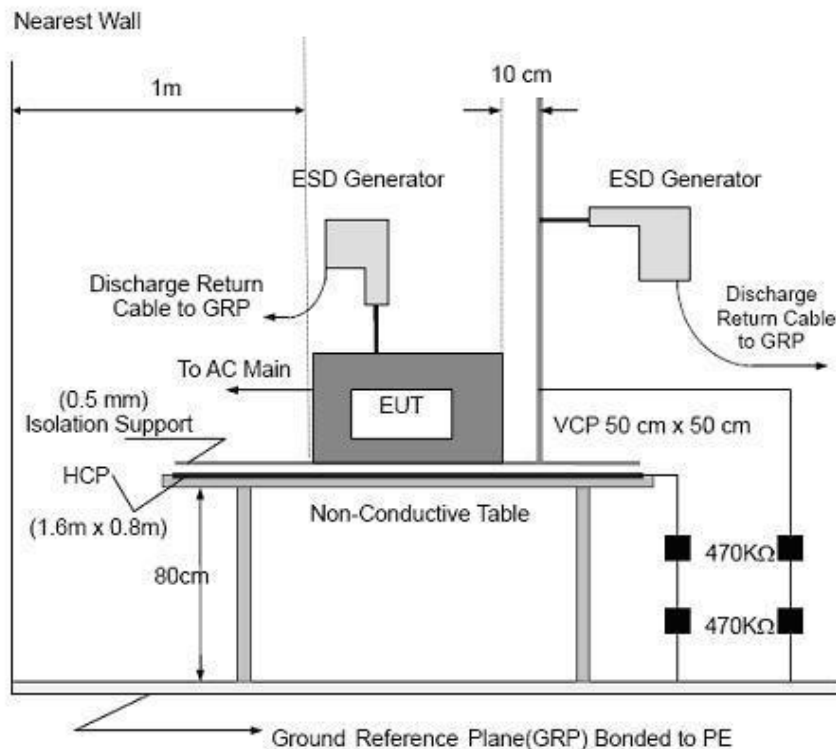

Huaxun testing (Shenzhen) Group Co., Ltd

Report No: E08230018-KY

Note:

TABLE-TOP EQUIPMENT

The configuration consisted of a wooden table 0.8 meters high standing on the Ground Reference Plane. The GRP consisted of a sheet of aluminum at least 0.25mm thick. A Horizontal Coupling Plane (1.6m x 0.8m) was placed on the table and attached to the GRP by means of a cable with 940k total impedance. The equipment under test, was installed in a representative system as described in section 7 of IEC /EN 61000-4-2, and its cables were placed on the HCP and isolated by an insulating support of 0.5mm thickness. A distance of 0.8-meter minimum was provided between the EUT and the walls of the laboratory and any other metallic structure.

FLOOR-STANDING EQUIPMENT

The equipment under test was installed in a representative system as described in section 7 of IEC/EN 61000-4-2, and its cables were isolated from the Ground Reference Plane by an insulating support of 0.1 meter thickness. The GRP was consisted of a sheet of aluminum that is at least 0.25mm thick, and extended at least 0.5 meters from the EUT on all sides.

5.3 TEST PROCEDURE

The test generator necessary to perform direct and indirect application of discharges to the EUT in the following manners:

1. Electrostatic discharges were applied only to those points and surfaces of the EUT that are accessible to users during normal operation. The test was performed with at least ten single discharges on the pre-selected points in the most sensitive polarity.
The time interval between two successive single discharges was at least 1 second.
The ESD generator was held perpendicularly to the surface to which the discharge was applied and the return cable was at least 0.2 meters from the EUT.
Contact discharges were applied to the non-insulating coating, with the pointed tip of the generator penetrating the coating and contacting the conducting substrate.
Air discharges were applied with the round discharge tip of the discharge electrode approaching the EUT as fast as possible (without causing mechanical damage) to touch the EUT. After each discharge, the ESD generator was removed from the EUT and re-triggered for a new single discharge. The test was repeated until all discharges were complete.

Vertical Coupling Plane (VCP):

The coupling plane, of dimensions 0.5m x 0.5m, is placed parallel to, and positioned at a distance 0.1m from, the EUT, with the Discharge Electrode touching the coupling plane.

The four faces of the EUT will be performed with electrostatic discharge.

Horizontal Coupling Plane (HCP):

The coupling plane is placed under to the EUT. The generator shall be positioned vertically at a distance of 0.1m from the EUT, with the Discharge Electrode touching the coupling plane.

The four faces of the EUT will be performed with electrostatic discharge.

2. Air discharges at insulation surfaces of the EUT.

It was at least ten single discharges with positive and negative at the same selected point.

Huaxun testing (Shenzhen) Group Co., Ltd

Report No: E08230018-KY

5.4 TEST RESULT

Temperature:	22°C	Relative Humidity:	48%
Test Voltage:	DC 5V	Pressure:	1010hPa
Test Mode:	Running		

Mode	Air Discharge								Contact Discharge								Perform Criteria	Result
	4		8		10		15		2		4		6		8			
Test Location	+	-	+	-	+	-	+	-	+	-	+	-	+	-	+	-		
HCP									A	A	A	A					B	PASS
VCP									A	A	A	A						PASS
Slots	A	A	A	A														PASS
Surface	A	A	A	A														PASS

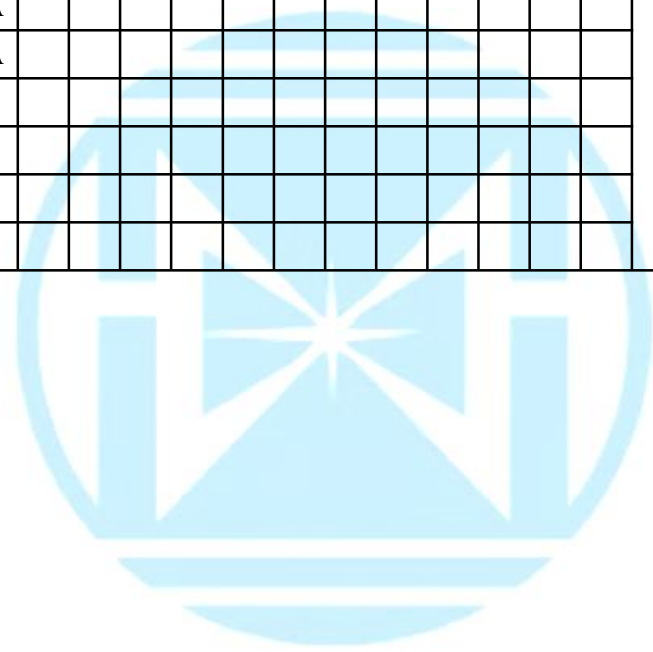

Huaxun testing (Shenzhen) Group Co., Ltd

Report No: E08230018-KY

6 RADIATED, RADIO-FREQUENCY, ELECTROMAGNETIC FIELD IMMUNITY TEST (RS)

6.1 TEST SPECIFICATION

Basic Standard:	IEC/EN 61000-4-3
Required Performance:	A
Frequency Range:	100Hz-20KHz
Field Strength:	3 V/m
Modulation:	1kHz Sine Wave, 80%, AM Modulation
Frequency Step:	1 % of fundamental
Polarity of Antenna:	Horizontal and Vertical
Test Distance:	3 m
Antenna Height:	1.5 m
Dwell Time:	1.5×10^{-3} decade/s

6.2 TEST SETUP

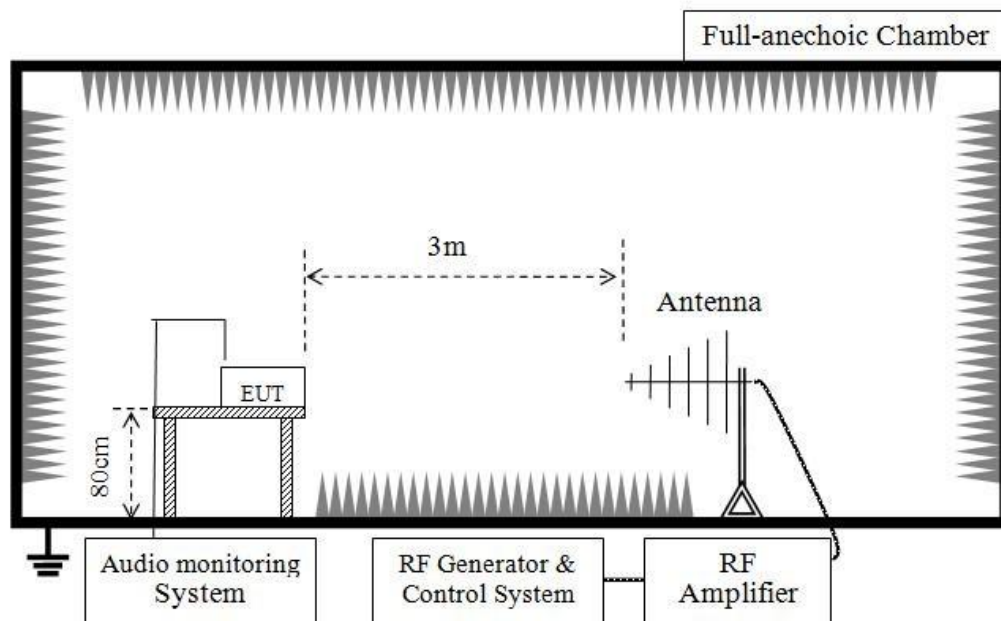

Huaxun testing (Shenzhen) Group Co., Ltd

Report No: E08230018-KY

Note:

TABLE-TOP EQUIPMENT

The EUT installed in a representative system as described in section 7 of IEC/EN 61000-4-3 was placed on a non-conductive table 0.8 meters in height. The system under test was connected to the power and signal wire according to relevant installation instructions.

FLOOR-STANDING EQUIPMENT

The EUT installed in a representative system as described in section 7 of IEC/EN 61000-4-3 was placed on a non-conductive wood support 0.1 meters in height. The system under test was connected to the power and signal wire according to relevant installation instructions.

6.3 TEST PROCEDURE

The EUT and support equipment, which are placed on a table that is 0.8 meter above ground and the testing was performed in a fully-anechoic chamber.

The testing distance from antenna to the EUT was 3 meters. The other condition need as following manners:

1. The frequency range is swept from 100 Hz to 20 KHz with the signal 80% amplitude modulated with a 1kHz sine wave. The rate of sweep did not exceed 1.5×10^{-3} decade/s. Where the frequency range is swept incrementally, the step size was 1% of fundamental.
2. The dwell time at each frequency shall be not less than the time necessary for the EUT to be able to respond.
3. The test was performed with the EUT exposed to both vertically and horizontally polarized fields on each of the four sides.

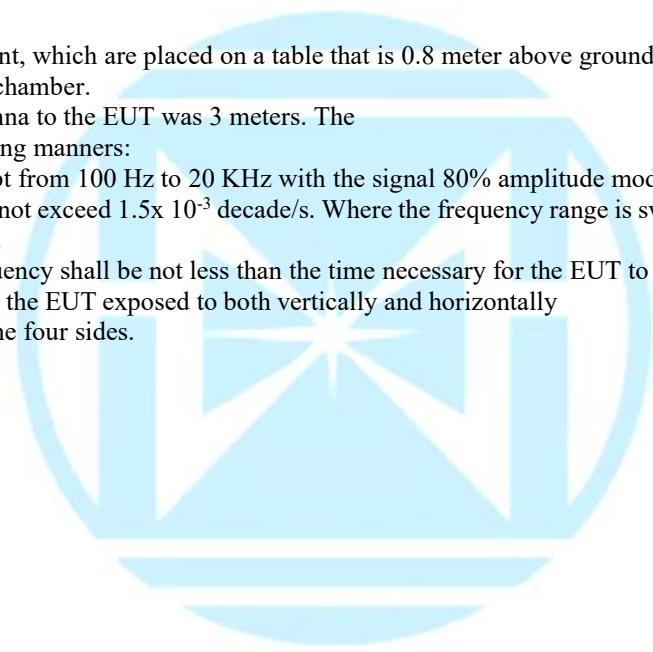

Huaxun testing (Shenzhen) Group Co., Ltd

Report No: E08230018-KY

6.4 TEST RESULT

Temperature:	22°C	Relative Humidity:	48%
Test Voltage:	DC 5V	Pressure:	1010hPa
Test Mode:	Running		

Frequency Range	RF Field Position	R.F. Field Strength	Azimuth	Observation	Perform Criteria	Result
100Hz-20KHz	H / V	3 V/m (rms) AM Modulated 100Hz, 80%	Front	CT, CR	A	PASS
			Rear			
			Left			
			Right			
Note:“A” stand for, during test, operate as intended no loss of function, no degradation of performance, no unintentional transmissions and after test, no degradation of performance, no loss of function, no loss of stored data or user programmable functions. 1) N/A - denotes test is not applicable in this test report. 2) Criteria A: There was no change operated with initial operating during the test. 3) Criteria B: The EUT function loss during the test, but self-recoverable after the test. 4) Criteria C: The system shut down during the test.						

Huaxun testing (Shenzhen) Group Co., Ltd

Report No: E08230018-KY

7 PHOTO OF EUT



PHOTO 01



PHOTO 02

Huaxun testing (Shenzhen) Group Co., Ltd

Report No: E08230018-KY

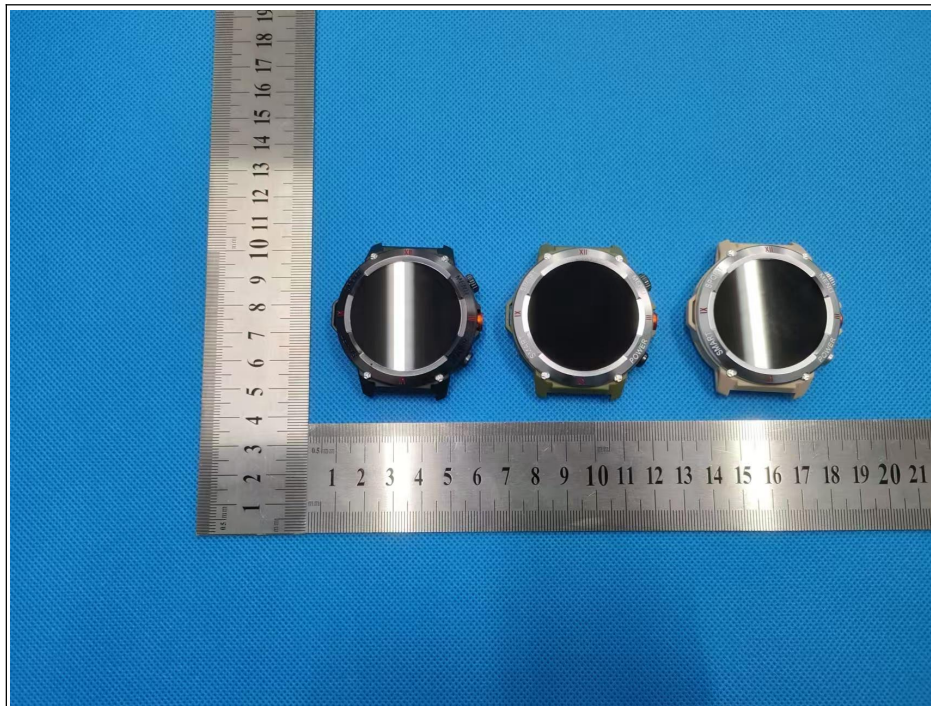

PHOTO 03

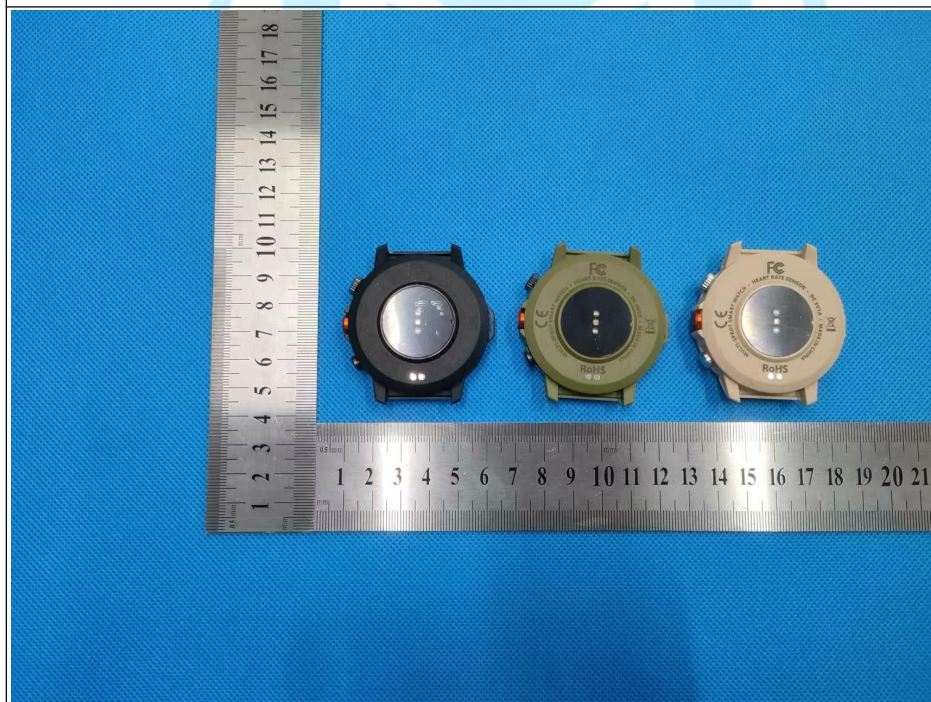

PHOTO 04

Huaxun testing (Shenzhen) Group Co., Ltd

Report No: E08230018-KY

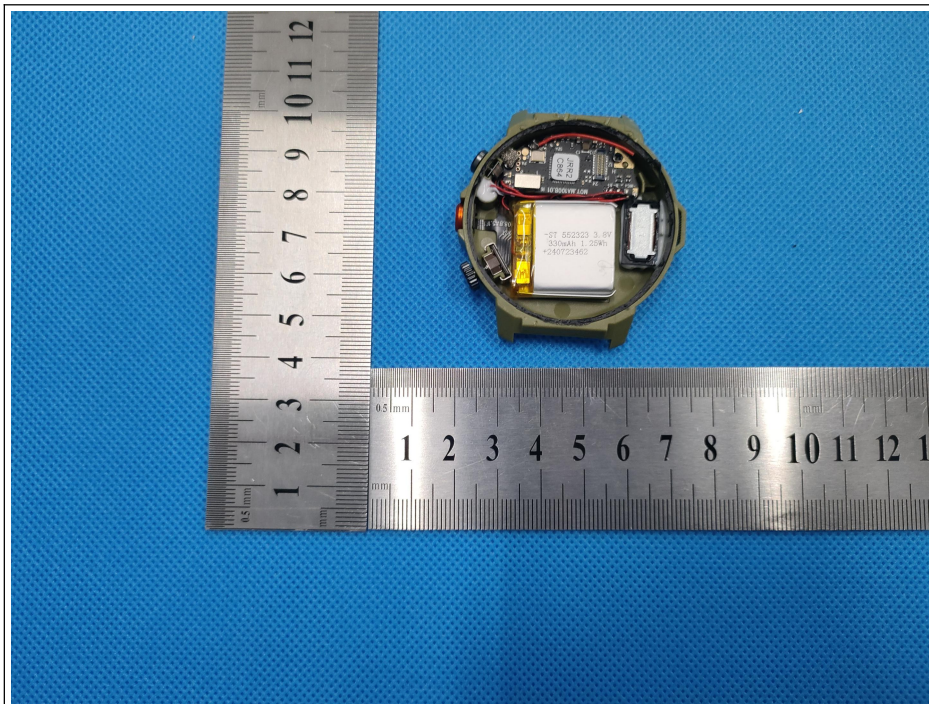

PHOTO 05

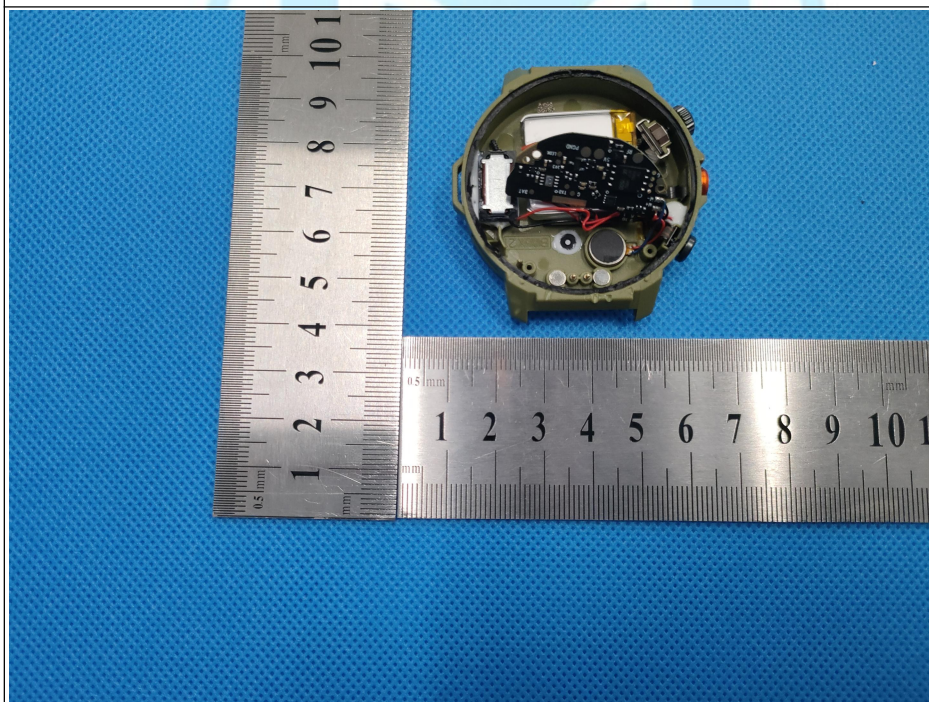

PHOTO 06

Huaxun testing (Shenzhen) Group Co., Ltd

Report No: E08230018-KY

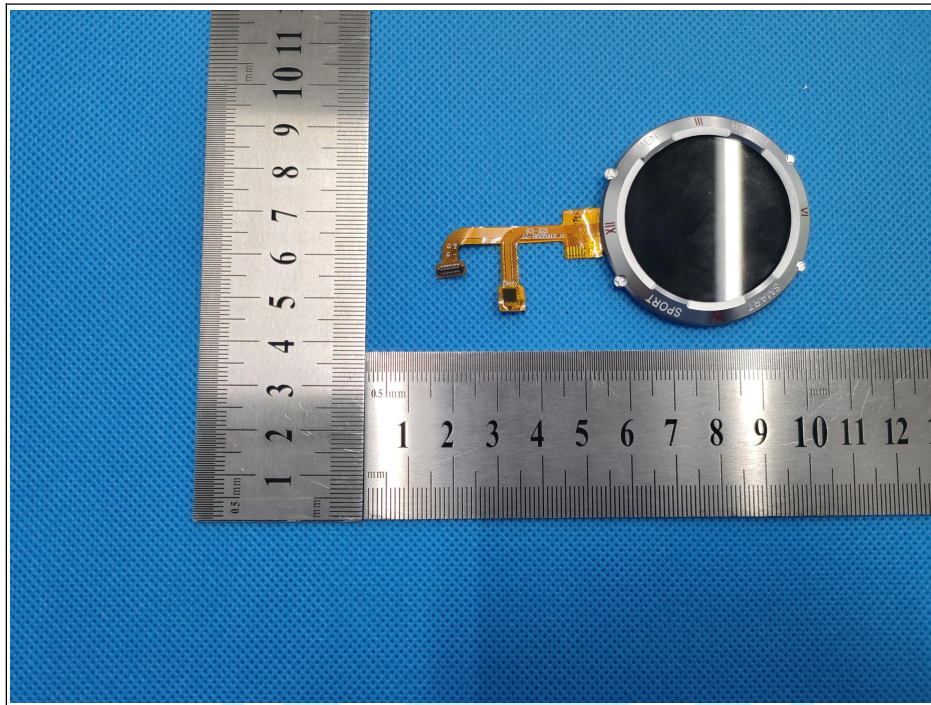

PHOTO 07

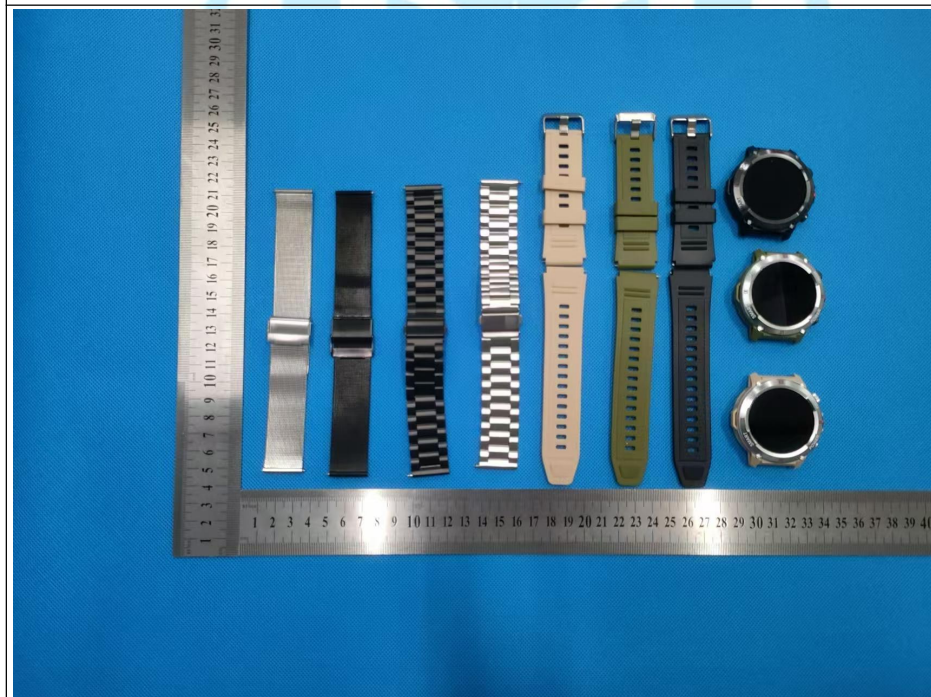

PHOTO 08

Huaxun testing (Shenzhen) Group Co., Ltd

Report No: E08230018-KY

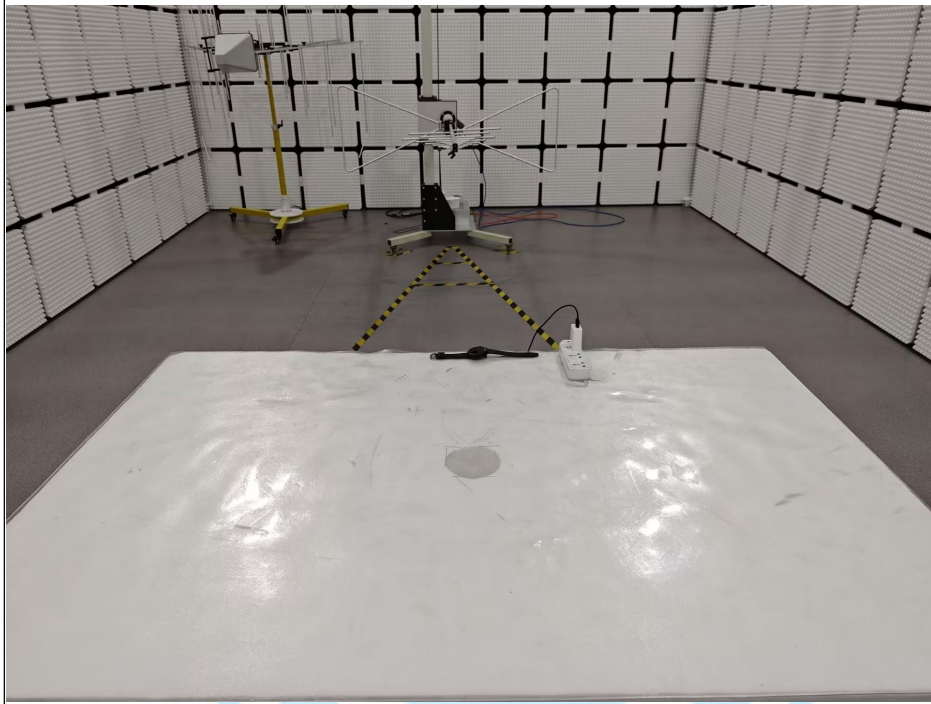

PHOTO 09

******End of Report******