

TEST REPORT

IEC 62133-2

Secondary cells and batteries containing alkaline or other non-acid electrolytes Safety requirements for portable sealed secondary cells, and for batteries made from them, for use in portable applications

Part 2: Lithium systems

Report Number: TCT240312B070

Date of issue: 2024-03-26

Total number of pages: 26 Pages.

Tested by (name + signature): May Hou

May Hou

Inspected by (name + signature): Aiden Liu

Aiden Liu

Approved by (name + signature): Tomsin

Tomsin



Testing laboratory: Shenzhen TCT Testing Technology Co., Ltd.

Address: 2101 & 2201, Zhenchang Factory, Renshan Industrial Zone, Fuhai Subdistrict, Bao'an District, Shenzhen, Guangdong, China

Testing location: As above

Applicant's name: Shenzhen YongqiHongye Technology Co., Ltd.

Address: No. A1, third floor, Building C, LilangDongren Logistics industrial Zone, Shanglilang Community, Nanwan Street, Longgang District, Shenzhen City. Guangdong Province

Manufacturer's name: Shenzhen YongqiHongye Technology Co., Ltd.

Address: No. A1, third floor, Building C, LilangDongren Logistics industrial Zone, Shanglilang Community, Nanwan Street, Longgang District, Shenzhen City. Guangdong Province

Test specification:

Standard: IEC 62133-2:2017, IEC 62133-2:2017/AMD1:2021

Test procedure: Type approved

Test result: Pass

Non-standard test method: N/A

The test results presented in this report relate only to the object tested. This report shall not be reproduced, except in full, without the written approval of the Issuing Shenzhen TCT Testing Technology Co., Ltd.

Test item description: Polymer Lithium Battery

Trade Mark: N/A

Model/type reference: YQ 701335

Ratings: 3.8V, 345mAh, 1.311Wh

List of Attachments (including a total number of pages in each attachment):

Attachment 1: Critical components information (page 22)

Attachment 2: Photo documentation (page 23-26)

Summary of testing:

Tests performed (name of test and test clause):

- cl.5.6.2 Design recommendation;
- cl.7.1 Charging procedure for test purposes (for Cells and Batteries);
- cl.7.2.1 Continuous charging at constant voltage (Cells);
- cl.7.3.1 External short circuit (Cells);
- cl.7.3.2 External short circuit (Batteries);
- cl.7.3.3 Free fall (Cells and Batteries);
- cl.7.3.4 Thermal abuse (Cells);
- cl.7.3.5 Crush (Cells);
- cl.7.3.6 Over-charging of battery;
- cl.7.3.7 Forced discharge (Cells);
- cl.7.3.8 Mechanical tests (Batteries);
- cl.7.3.9 Design evaluation – Forced internal short circuit (Cells)

The electrolyte type of this cell doesn't belong to polymer, and the addition test cl.7.3.9 was carried out to evaluate the cell.

Tests are made with the number of cells and batteries specified in IEC 62133-2:2017, IEC 62133-2:2017/AMD1:2021 Table 1.

Testing location:

Shenzhen TCT Testing Technology Co., Ltd.
2101 & 2201, Zhenchang Factory, Renshan Industrial Zone, Fuhai Subdistrict, Bao'an District, Shenzhen, Guangdong, China

The product fulfils the requirements of EN 62133-2:2017, EN 62133-2:2017/A1:2021

Use of uncertainty of measurement for decisions on conformity (decision rule) :

No decision rule is specified by the IEC standard, when comparing the measurement result with the applicable limit according to the specification in that standard. The decisions on conformity are made without applying the measurement uncertainty ("simple acceptance" decision rule, previously known as "accuracy method").

Other: N/A (to be specified, for example when required by the standard or client, or if national accreditation requirements apply)

Information on uncertainty of measurement:

The uncertainties of measurement are calculated by the laboratory based on application of criteria given by OD-5014 for test equipment and application of test methods, decision sheets and operational procedures of IECEE.

IEC Guide 115 provides guidance on the application of measurement uncertainty principles and applying the decision rule when reporting test results within IECEE scheme, noting that the reporting of the measurement uncertainty for measurements is not necessary unless required by the test standard or customer.

Calculations leading to the reported values are on file with the NCB and testing laboratory that conducted the testing.

Copy of marking plate:

The artwork below may be only a draft

- (Black) Polymer Lithium Battery
Model: YQ 701335 1ICP8/14/34
3.8V, 345mAh, 1.311Wh
Shenzhen YongqiHongye Technology Co., Ltd.

+ (Red) Date: YYYYMM Made in China

WARNING: Risk of Fire and Burns. Do Not Open, Crush, Heat Above 60°C/140°F or Incinerate. Do not short circuit. If bulges severely, discontinue use. Follow Manufacturer's Instructions.

Date code: YYYYMM

YYYY=Year, MM= Month.

Information for safety mentioned on equipment's package:

Warning language

1. Keep small cells which are considered swallowable out of the reach of children.
2. Swallowing may lead to burns, perforation of soft tissue, and death. Severe burns can occur within 2h of ingestion.
3. In case of ingestion of a cell, seek medical assistance promptly.

Test item particulars..... :	
Classification of installation and use..... :	To be defined in final product
Supply Connection	DC Lead wire
Recommend charging method declared by the manufacturer	Charging the battery with 69mA constant current and 4.35V constant voltage until the current reduces to 6.9mA at ambient 20°C±5°C.
Discharge current (0,2 It A)	69mA
Specified final voltage.....	3.0V
Upper limit charging voltage per cell.....	4.35V
Maximum charging current	345mA
Charging temperature upper limit	45°C
Charging temperature lower limit.....	0°C
Polymer cell electrolyte type	<input type="checkbox"/> gel polymer <input type="checkbox"/> solid polymer <input checked="" type="checkbox"/> N/A
Possible test case verdicts:	
- test case does not apply to the test object..... : N/A	
- test object does meet the requirement..... : P (Pass)	
- test object does not meet the requirement..... : F (Fail)	
Testing..... :	
Date of receipt of test item	2024-03-12
Date (s) of performance of tests	2024-03-12 to 2024-03-26
General remarks:	
The test results presented in this report relate only to the object tested, This report shall not be reproduced, except in full, without the written approval of the issuing testing laboratory, “(Cell #XX)” refers to sample number of cells, “X” is 0~9; “(Battery #XX)” refers to sample number of batteries, “X” is 0~9; “(see below table)” refers to a table appended to the report.	
Throughout this report a point is used as the decimal separator.	
When differences exist; they shall be identified in the General product information section.	
Name and address of factory (ies)	Same as manufacturer.

General product information and other remarks:

This battery is constructed with single lithium-ion cell, and has overcharge, over-discharge, over current and short-circuits proof circuit.

The main features of the battery are shown as below (clause 7.1.1):

Model (Battery)	Nominal capacity	Nominal voltage	Nominal Charge Current	Nominal Discharge Current	Maximum Charge Current	Maximum Discharge Current	Maximum Charge Voltage	Final Voltage
YQ 701335	345mAh	3.8V	69mA	69mA	345mA	345mA	4.35V	3.0V

The main features of the cell in the battery are shown as below (clause 7.1.1):

Model (Cell)	Nominal capacity	Nominal voltage	Nominal Charge Current	Nominal Discharge Current	Maximum Charge Current	Maximum Discharge Current	Maximum Charge Voltage	Final Voltage
YQ 701335	345mAh	3.8V	69mA	69mA	345mA	345mA	4.35V	3.0V

The main features of the cell in the battery are shown as below (clause 7.1.2):

Model (Cell)	Upper limit charge voltage	Taper-off current (0.05 It A)	Lower charge temperature	Upper charge temperature
YQ 701335	4.35V	17.25mA	0°C	45°C

Construction:

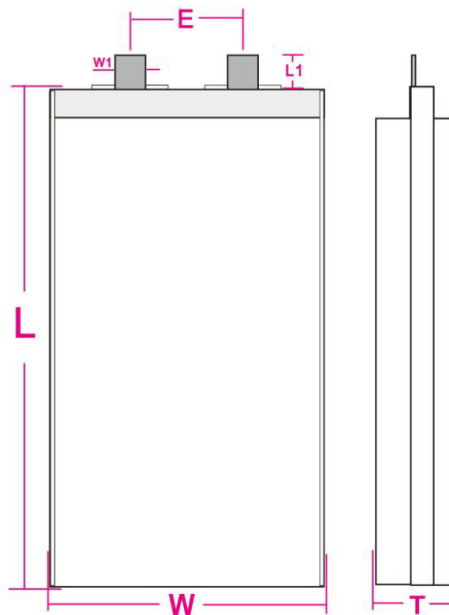

T	W	L
≤7.1	≤ 13.2	≤ 33.5±0.5

Cell (Unit: mm)

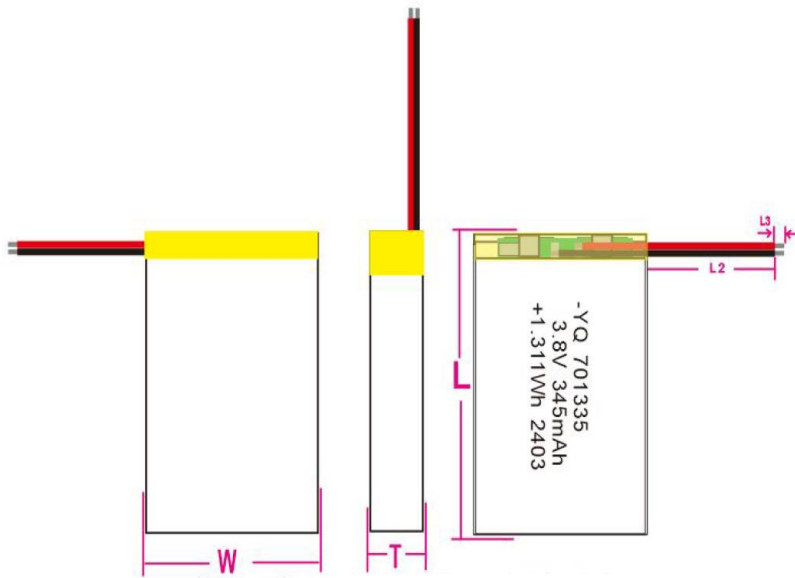

(T)	≤ 7.1 mm Max
(W)	≤ 13.2 mm Max
(L)	≤ 35.3 mm Max

Battery

Circuit diagram:

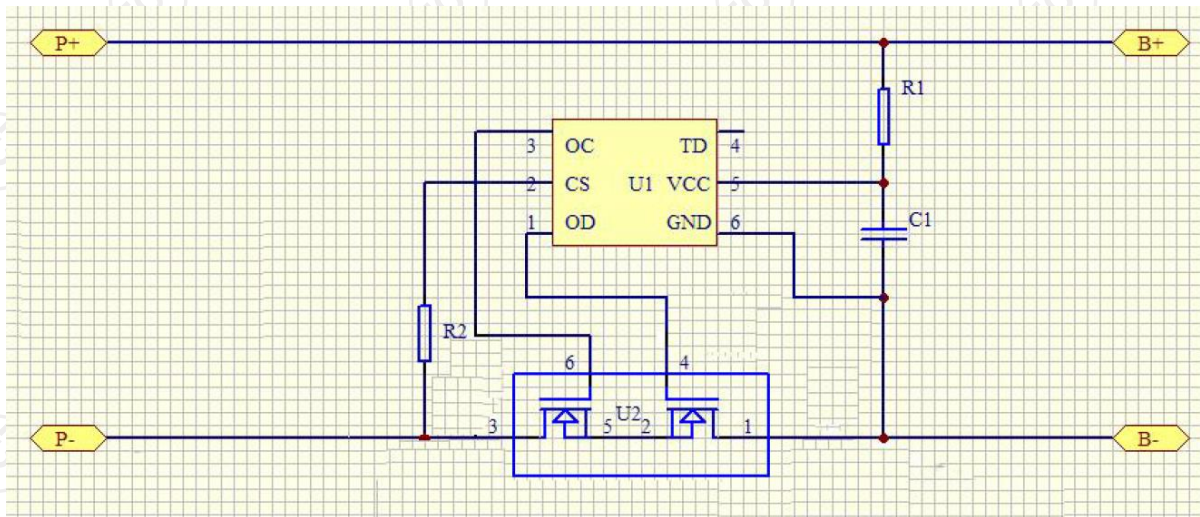

IEC 62133-2			
Clause	Requirement + Test	Result - Remark	Verdict
4	PARAMETER MEASUREMENT TOLERANCES		P
	Parameter measurement tolerances		P
5	GENERAL SAFETY CONSIDERATIONS		P
5.1	General		P
	Cells and batteries so designed and constructed that they are safe under conditions of both intended use and reasonably foreseeable misuse		P
5.2	Insulation and wiring		P
	The insulation resistance between the positive terminal and externally exposed metal surfaces of the battery (excluding electrical contact surfaces) is not less than 5 MΩ	No metal surface exists.	N/A
	Insulation resistance (MΩ) :		—
	Internal wiring and insulation are sufficient to withstand maximum anticipated current, voltage and temperature requirements		P
	Orientation of wiring maintains adequate clearance and creepage distances between conductors		P
	Mechanical integrity of internal connections accommodates reasonably foreseeable misuse		P
5.3	Venting		P
	Battery cases and cells incorporate a pressure relief mechanism or are constructed so that they relieve excessive internal pressure at a value and rate that will preclude rupture, explosion and self-ignition	Venting mechanism exists on the narrow side of pouch cell.	P
	Encapsulation used to support cells within an outer casing does not cause the battery to overheat during normal operation nor inhibit pressure relief		N/A
5.4	Temperature, voltage and current management		P
	Batteries are designed such that abnormal temperature rise conditions are prevented	Overcharge, over discharge, over current and short-circuit proof circuit used in this battery. See tests of clause 7.	P
	Batteries are designed to be within temperature, voltage and current limits specified by the cell manufacturer	See above.	P
	Batteries are provided with specifications and charging instructions for equipment manufacturers so that specified chargers are designed to maintain charging within the temperature, voltage and current limits specified	The charging limits specified in the manufacturer's specification.	P
5.5	Terminal contacts		P

IEC 62133-2			
Clause	Requirement + Test	Result - Remark	Verdict
	The size and shape of the terminal contacts ensure that they can carry the maximum anticipated current	DC Lead wire contacts complied with the requirements.	P
	External terminal contact surfaces are formed from conductive materials with good mechanical strength and corrosion resistance		P
	Terminal contacts are arranged to minimize the risk of short-circuit		P
5.6	Assembly of cells into batteries		P
5.6.1	General		P
	Each battery have an independent control and protection for current, voltage, temperature and any other parameter required for safety and to maintain the cells within their operating region	Protective circuit equipped on battery.	P
	This protection may be provided external to the battery such as within the charger or the end devices		N/A
	If protection is external to the battery, the manufacturer of the battery provide this safety relevant information to the external device manufacturer for implementation		N/A
	If there is more than one battery housed in a single battery case, each battery have protective circuitry that can maintain the cells within their operating regions		N/A
	Manufacturers of cells specify current, voltage and temperature limits so that the battery manufacturer/designer may ensure proper design and assembly	Current, voltage and temperature limits specified by cell manufacturer.	P
	Batteries that are designed for the selective discharge of a portion of their series connected cells incorporate circuitry to prevent operation of cells outside the limits specified by the cell manufacturer		N/A
	Protective circuit components added as appropriate and consideration given to the end-device application		P
	The manufacturer of the battery provide a safety analysis of the battery safety circuitry with a test report including a fault analysis of the protection circuit under both charging and discharging conditions confirming the compliance	Safety analysis report provided by manufacturer.	P
5.6.2	Design recommendation		P
	For the battery consisting of a single cell or a single cellblock, it is recommended that the charging voltage of the cell does not exceed the upper limit of the charging voltage specified in Table 2	Single cell battery, Max. Charging voltage of cell: 4.35V.	P

IEC 62133-2			
Clause	Requirement + Test	Result - Remark	Verdict
	For the battery consisting of series-connected plural single cells or series-connected plural cellblocks, it is recommended that the voltages of any one of the single cells or single cellblocks does not exceed the upper limit of the charging voltage, specified in Table 2, by monitoring the voltage of every single cell or the single cellblocks		N/A
	For the battery consisting of series-connected plural single cells or series-connected plural cellblocks, it is recommended that charging is stopped when the upper limit of the charging voltage is exceeded for any one of the single cells or single cellblocks by measuring the voltage of every single cell or the single cellblocks		N/A
	For batteries consisting of series-connected cells or cell blocks, nominal charge voltage not be counted as an overcharge protection		N/A
	For batteries consisting of series-connected cells or cell blocks, cells have closely matched capacities, be of the same design, be of the same chemistry and be from the same manufacturer		N/A
	It is recommended that the cells and cell blocks not discharged beyond the cell manufacturer's specified final voltage	Final voltage of cell: 3.0V, not exceed the final voltage specified by cell manufacturer.	P
	For batteries consisting of series-connected cells or cell blocks, cell balancing circuitry incorporated into the battery management system		N/A
5.6.3	Mechanical protection for cells and components of batteries		P
	Mechanical protection for cells, cell connections and control circuits within the battery provided to prevent damage as a result of intended use and reasonably foreseeable misuse	Mechanical protection for cell connections and control circuits provided.	P
	The mechanical protection can be provided by the battery case or it can be provided by the end product enclosure for those batteries intended for building into an end product	Build-in batteries, mechanical protection for cells should be provided by end product.	N/A
	The battery case and compartments housing cells designed to accommodate cell dimensional tolerances during charging and discharging as recommended by the cell manufacturer	To be evaluated in final system.	N/A
	For batteries intended for building into a portable end product, testing with the battery installed within the end product considered when conducting mechanical tests		N/A
5.7	Quality plan		P

IEC 62133-2			
Clause	Requirement + Test	Result - Remark	Verdict
	The manufacturer prepares and implements a quality plan that defines procedures for the inspection of materials, components, cells and batteries and which covers the whole process of producing each type of cell or battery	Complied. Quality plan provided.	P
5.8	Battery safety components		N/A
	According annex F	See TABLE: Critical components information	N/A

6	TYPE TEST AND SAMPLE SIZE		P
	Tests are made with the number of cells or batteries specified in Table 1 using cells or batteries that are not more than six months old		P
	Coin cells with resistance $\leq 3 \Omega$ (measured according annex D) are tested according table 1	Not coin cells	N/A
	Unless otherwise specified, tests are carried out in an ambient temperature of $20 \text{ }^\circ\text{C} \pm 5 \text{ }^\circ\text{C}$		P
	The safety analysis of 5.6.1 identify those components of the protection circuit that are critical for short-circuit, overcharge and overdischarge protection		P
	When conducting the short-circuit test, consideration given to the simulation of any single fault condition that is likely to occur in the protecting circuit that would affect the short-circuit test	See clause 7.3.2.	P

7	SPECIFIC REQUIREMENTS AND TESTS		P
7.1	Charging procedure for test purposes		P
7.1.1	First procedure		P
	This charging procedure applies to subclauses other than those specified in 7.1.2		P
	Unless otherwise stated in this document, the charging procedure for test purposes is carried out in an ambient temperature of $20 \text{ }^\circ\text{C} \pm 5 \text{ }^\circ\text{C}$, using the method declared by the manufacturer	See page 4.	P
	Prior to charging, the battery have been discharged at $20 \text{ }^\circ\text{C} \pm 5 \text{ }^\circ\text{C}$ at a constant current of 0,2 It A down to a specified final voltage	See page 4.	P
7.1.2	Second procedure		P
	This charging procedure applies only to 7.3.1, 7.3.4, 7.3.5, and 7.3.9		P

IEC 62133-2			
Clause	Requirement + Test	Result - Remark	Verdict
	After stabilization for 1 h and 4 h, respectively, at ambient temperature of highest test temperature and lowest test temperature, as specified in Table 2, cells are charged by using the upper limit charging voltage and maximum charging current, until the charging current is reduced to 0,05 It A, using a constant voltage charging method	Charge temperature specified by manufacturer: 0-45°C. 0°C used for lower limit tests. 45°C used for upper limit tests.	P
7.2	Intended use		P
7.2.1	Continuous charging at constant voltage (cells)		P
	Fully charged cells are subjected for 7 days to a charge using the charging method for current and standard voltage specified by the cell manufacturer	Charging for 7days with 69mA.	P
	Results: No fire. No explosion. No leakage.....:	(See appended table 7.2.1)	P
7.2.2	Case stress at high ambient temperature (battery)		N/A
	Oven temperature (°C).....:		—
	Results: No physical distortion of the battery case resulting in exposure of internal protective components and cells		N/A
7.3	Reasonably foreseeable misuse		P
7.3.1	External short-circuit (cell)	Tested complied.	P
	The cells were tested until one of the following occurred:		P
	- 24 hours elapsed; or		N/A
	- The case temperature declined by 20 % of the maximum temperature rise		P
	Results: No fire. No explosion.....:	(See appended table 7.3.1)	P
7.3.2	External short-circuit (battery)	Tested complied.	P
	The batteries were tested until one of the following occurred:		P
	- 24 hours elapsed; or		N/A
	- The case temperature declined by 20 % of the maximum temperature rise		P
	In case of rapid decline in short circuit current, the battery pack remained on test for an additional one hour after the current reached a low end steady state condition		P
	A single fault in the discharge protection circuit conducted on one to four (depending upon the protection circuit) of the five samples before conducting the short-circuit test	Single fault conducted on three samples.	P
	A single fault applies to protective component parts such as MOSFET, fuse, thermostat or positive temperature coefficient (PTC) thermistor	Single fault applies on MOSFET U2.	P
	Results: No fire. No explosion.....:	(See appended table 7.3.2)	P

IEC 62133-2			
Clause	Requirement + Test	Result - Remark	Verdict
7.3.3	Free fall	Tested complied.	P
	Results: No fire. No explosion	No fire. No explosion	P
7.3.4	Thermal abuse (cells)	Tested complied.	P
	Oven temperature (°C) : 130°C		—
	Results: No fire. No explosion	No fire. No explosion	P
7.3.5	Crush (cells)	Tested complied.	P
	The crushing force was released upon:		P
	- The maximum force of 13 kN ± 0,78 kN has been applied; or		P
	- An abrupt voltage drop of one-third of the original voltage has been obtained		N/A
	Results: No fire. No explosion..... : (See appended table 7.3.5)		P
7.3.6	Over-charging of battery	Tested complied.	P
	The supply voltage which is:		P
	- 1,4 times the upper limit charging voltage presented in Table A.1 (but not to exceed 6,0 V) for single cell/cell block batteries or	6.0V applied.	P
	- 1,2 times the upper limit charging voltage resented in Table A.1 per cell for series connected multi-cell batteries, and		N/A
	- Sufficient to maintain a current of 2,0 It A throughout the duration of the test or until the supply voltage is reached		P
	Test was continued until the temperature of the outer casing:		P
	- Reached steady state conditions (less than 10 °C change in 30-minute period); or		N/A
	- Returned to ambient		P
	Results: No fire. No explosion..... : (See appended table 7.3.6)		P
7.3.7	Forced discharge (cells)	Tested complied.	P
	Discharge a single cell to the lower limit discharge voltage specified by the cell manufacturer	Lower limit discharge voltage 3.0V	P
	The discharged cell is then subjected to a forced discharge at 1 It A to the negative value of the upper limit charging voltage		P
	- The discharge voltage reaches the negative value of upper limit charging voltage within the testing duration. The voltage is maintained at the negative value of the upper limit charging voltage by reducing the current for the remainder of the testing duration		N/A

IEC 62133-2			
Clause	Requirement + Test	Result - Remark	Verdict
	- The discharge voltage does not reach the negative value of upper limit charging voltage within the testing duration. The test is terminated at the end of the testing duration		P
	Results: no fire, no explosion	(See appended table 7.3.7)	P
7.3.8	Mechanical tests (batteries)		P
7.3.8.1	Vibration	Tested complied.	P
	Results: No fire, no explosion, no rupture, no leakage or venting.	(See appended table 7.3.8.1)	P
7.3.8.2	Mechanical shock	Tested complied.	P
	Results: No leakage, no venting, no rupture, no explosion and no fire	(See appended table 7.3.8.2)	P
7.3.9	Design evaluation – Forced internal short-circuit (cells)	Tested complied.	P
	The cells complied with national requirement for	France, Japan, Republic of Korea and Switzerland.	—
	The pressing was stopped upon:		P
	- A voltage drop of 50 mV has been detected; or		N/A
	- The pressing force of 800 N (cylindrical cells) or 400 N (prismatic cells) has been reached	400N for prismatic cell.	P
	Results: No fire	(See appended table 7.3.9)	P
8	INFORMATION FOR SAFETY		P
8.1	General		P
	Manufacturers of secondary cells ensure that information is provided about current, voltage and temperature limits of their products	Information for safety mentioned in manufacturer's specifications.	P
	Manufacturers of batteries ensure that equipment manufacturers and, in the case of direct sales, end-users are provided with information to minimize and mitigate hazards	Information for safety mentioned in manufacturer's specifications.	P
	Systems analyses performed by device manufacturers to ensure that a particular battery design prevents hazards from occurring during use of a product		N/A
	As appropriate, any information relating to hazard avoidance resulting from a system analysis provided to the end user		N/A
8.2	Small cell and battery safety information	Small cells and batteries.	P
	The following warning language is to be provided with the information packaged with the small cells and batteries or equipment using them:	Information for safety mentioned in manufacturer's specifications and on equipment's package.	P

IEC 62133-2			
Clause	Requirement + Test	Result - Remark	Verdict
	- Keep small cells and batteries which are considered swallowable out of the reach of children		P
	- Swallowing may lead to burns, perforation of soft tissue, and death. Severe burns can occur within 2 h of ingestion		P
	- In case of ingestion of a cell or battery, seek medical assistance promptly		P
9	MARKING		P
9.1	Cell marking	The final product is battery	N/A
	Cells marked as specified in IEC 61960, except coin cells		N/A
	Coin cells whose external surface area is too small to accommodate the markings on the cells show the designation and polarity		N/A
	By agreement between the cell manufacturer and the battery and/or end product manufacturer, component cells used in the manufacture of a battery need not be marked		N/A
9.2	Battery marking		P
	Batteries are marked as specified in IEC 61960, except for coin batteries	See marking plate on page 3.	P
	Coin batteries whose external surface area is too small to accommodate the markings on the batteries show the designation and polarity	Not coin batteries.	N/A
	Batteries are marked with an appropriate caution statement		P
	- Terminals have clear polarity marking on the external surface of the battery, or	The “- (Black)” and “+ (Red)” polarity explicitly marked on surface of the battery.	P
	- Not be marked with polarity markings if the design of the external connector prevents reverse polarity connections		N/A
9.3	Caution for ingestion of small cells and batteries		N/A
	Coin cells and batteries identified as small batteries include a caution statement regarding the hazards of ingestion in accordance with 8.2	Not coin cells. Not coin batteries.	N/A
	Small cells and batteries are intended for direct sale in consumer-replaceable applications, caution for ingestion is given on the immediate package	Not intended for direct sale.	N/A
9.4	Other information		P
	The following information are marked on or supplied with the battery:		P

IEC 62133-2			
Clause	Requirement + Test	Result - Remark	Verdict
	- Storage and disposal instructions	Information for storage and disposal instructions mentioned in manufacturer's specifications.	P
	- Recommended charging instructions	Information for recommended charging instructions mentioned in manufacturer's specifications.	P
10	PACKAGING AND TRANSPORT		N/A
	Packaging for coin cells are not be small enough to fit within the limits of the ingestion gauge of Figure 3	Not coin cells.	N/A

ANNEX A	CHARGING AND DISCHARGING RANGE OF SECONDARY LITHIUM ION CELLS FOR SAFE USE		P
A.1	General		P
A.2	Safety of lithium ion secondary battery	Complied.	P
A.3	Consideration on charging voltage	Complied.	P
A.3.1	General		P
A.3.2	Upper limit charging voltage	4.35V applied.	P
A.3.2.1	General		P
A.3.2.2	Explanation of safety viewpoint		P
A.3.2.3	Safety requirements, when different upper limit charging voltage is applied	4.35V applied.	P
A.4	Consideration of temperature and charging current		P
A.4.1	General		P
A.4.2	Recommended temperature range	See A.4.2.2.	P
A.4.2.1	General		P
A.4.2.2	Safety consideration when a different recommended temperature range is applied	Charging temperature range declared by client is: 0-45°C	P
A.4.3	High temperature range		N/A
A.4.3.1	General		N/A
A.4.3.2	Explanation of safety viewpoint		N/A
A.4.3.3	Safety considerations when specifying charging conditions in the high temperature range		N/A
A.4.3.4	Safety considerations when specifying a new upper limit in the high temperature range		N/A
A.4.4	Low temperature range		N/A
A.4.4.1	General		N/A
A.4.4.2	Explanation of safety viewpoint		N/A

IEC 62133-2			
Clause	Requirement + Test	Result - Remark	Verdict
A.4.4.3	Safety considerations, when specifying charging conditions in the low temperature range		N/A
A.4.4.4	Safety considerations when specifying a new lower limit in the low temperature range		N/A
A.4.5	Scope of the application of charging current		P
A.4.6	Consideration of discharge		P
A.4.6.1	General		P
A.4.6.2	Final discharge voltage and explanation of safety viewpoint	Cell specified final voltage 3.0V, not exceed 3.0V specified by cell manufacturer.	P
A.4.6.3	Discharge current and temperature range		P
A.4.6.4	Scope of application of the discharging current		P
A.5	Sample preparation		P
A.5.1	General		P
A.5.2	Insertion procedure for nickel particle to generate internal short		P
A.5.3	Disassembly of charged cell		P
A.5.4	Shape of nickel particle		P
A.5.5	Insertion of nickel particle in cylindrical cell		N/A
A.5.5.1	Insertion of nickel particle in winding core		N/A
A.5.5.2	Marking the position of the nickel particle on both ends of the winding core of the separator		N/A
A.5.6	Insertion of nickel particle in prismatic cell		P
A.6	Experimental procedure of the forced internal short-circuit test		P
A.6.1	Material and tools for preparation of nickel particle		P
A.6.2	Example of a nickel particle preparation procedure		P
A.6.3	Positioning (or placement) of a nickel particle		P
A.6.4	Damaged separator precaution		P
A.6.5	Caution for rewinding separator and electrode		P
A.6.6	Insulation film for preventing short-circuit		P
A.6.7	Caution when disassembling a cell		P
A.6.8	Protective equipment for safety		P
A.6.9	Caution in the case of fire during disassembling		P
A.6.10	Caution for the disassembling process and pressing the electrode core		P
A.6.11	Recommended specifications for the pressing device		P

IEC 62133-2			
Clause	Requirement + Test	Result - Remark	Verdict
ANNEX B	RECOMMENDATIONS TO EQUIPMENT MANUFACTURERS AND BATTERY ASSEMBLERS		N/A
ANNEX C	RECOMMENDATIONS TO THE END-USERS		N/A
ANNEX D	MEASUREMENT OF THE INTERNAL AC RESISTANCE FOR COIN CELLS		N/A
D.1	General	Not coin cells.	N/A
D.2	Method		N/A
	A sample size of three coin cells is required for this measurement..... :	(See appended table D.2)	N/A
	Coin cells with an internal resistance of less than or equal to 3 Ω are subjected to the testing according to Clause 6 and Table 1		N/A
	Coin cells with an internal resistance greater than 3 Ω require no further testing		N/A
ANNEX E	PACKAGING AND TRANSPORT		N/A
ANNEX F	COMPONENT STANDARDS REFERENCES		N/A

7.2.1	TABLE: Continuous charging at constant voltage (cells)				P
Sample no.	Recommended charging voltage Vc (Vdc)	Recommended charging current I _{rec} (mA)	OCV before test (Vdc)	Results	
Cell #1	4.35	69	4.32	P	
Cell #2	4.35	69	4.32	P	
Cell #3	4.35	69	4.33	P	
Cell #4	4.35	69	4.33	P	
Cell #5	4.35	69	4.33	P	
Supplementary information:					
- No fire or explosion					
- No leakage					

7.3.1	TABLE: External short-circuit (cell)				P
Sample no.	Ambient T (°C)	OCV before test (Vdc)	Resistance of circuit (mΩ)	Maximum case temperature rise ΔT, °C	Results
Samples charged at charging temperature upper limit (45°C)					
Cell #1	55.2	4.33	82	121.2	P
Cell #2	55.2	4.32	81	119.5	P
Cell #3	55.2	4.33	83	122.1	P
Cell #4	55.2	4.32	82	118.8	P
Cell #5	55.2	4.33	80	120.6	P
Samples charged at charging temperature lower limit (0°C)					
Cell #6	55.2	4.29	84	113.5	P
Cell #7	55.2	4.28	82	114.2	P
Cell #8	55.2	4.29	81	115.1	P
Cell #9	55.2	4.29	83	112.3	P
Cell #10	55.2	4.28	84	113.9	P
Supplementary information:					
- No fire or explosion					

7.3.2 TABLE: External short-circuit (battery)						P
Sample no.	Ambient T (°C)	OCV before test (Vdc)	Resistance of circuit (mΩ)	Maximum case temperature rise ΔT, °C	Component single fault condition	Results
Battery #1	23.2	4.33	85	107.4	Short circuit MOSFET U2	P
Battery #2	23.2	4.33	82	108.1	Short circuit MOSFET U2	P
Battery #3	23.2	4.32	83	107.9	Short circuit MOSFET U2	P
Battery #4	23.2	4.32	81	23.3	--	P
Battery #5	23.2	4.33	84	23.4	--	P
Supplementary information: - No fire or explosion						

7.3.5 TABLE: Crush (cells)				P
Sample no.	OCV before test (Vdc)	OCV at removal of crushing force (Vdc)	Maximum force applied to the cell during crush (kN)	Results
Samples charged at charging temperature upper limit (45°C)				
Cell #1	4.33	4.33	13.02	P
Cell #2	4.33	4.33	13.01	P
Cell #3	4.32	4.32	13.03	P
Cell #4	4.33	4.33	13.04	P
Cell #5	4.33	4.33	13.04	P
Samples charged at charging temperature lower limit (0°C)				
Cell #6	4.28	4.28	13.02	P
Cell #7	4.29	4.29	13.03	P
Cell #8	4.28	4.28	13.02	P
Cell #9	4.29	4.29	13.04	P
Cell #10	4.29	4.29	13.01	P
Note: A 13kN force applied at the wide side of prismatic cells. No voltage abrupt occurred.				
Supplementary information: - No fire or explosion				

7.3.6 TABLE: Over-charging of battery				P
Constant charging current (A)		0.69		—
Supply voltage (Vdc)		6.0		—
Sample no.	OCV before charging (Vdc)	Total charging time (minute)	Maximum outer case temperature (°C)	Results
Battery #1	3.41	100	32.3	P
Battery #2	3.42	100	31.5	P
Battery #3	3.42	100	32.4	P
Battery #4	3.41	100	33.3	P
Battery #5	3.42	100	32.9	P
Supplementary information: - No fire or explosion				

7.3.7 TABLE: Forced discharge (cells)				P
Sample no.	OCV before application of reverse charge (Vdc)	Measured reverse charge I_t (mA)	Lower limit discharge voltage (Vdc)	Results
Cell #1	3.38	345	3.0	P
Cell #2	3.37	345	3.0	P
Cell #3	3.37	345	3.0	P
Cell #4	3.36	345	3.0	P
Cell #5	3.38	345	3.0	P
Supplementary information: - No fire or explosion				

7.3.8.1 TABLE: Vibration					P
Sample no.	OCV before test (Vdc)	OCV after test (Vdc)	Mass before test (g)	Mass after test (g)	Results
Battery #1	4.33	4.33	5.531	5.531	P
Battery #2	4.33	4.33	5.530	5.530	P
Battery #3	4.33	4.33	5.382	5.382	P
Supplementary information: - No fire or explosion - No rupture - No leakage - No venting					

7.3.8.2 TABLE: Mechanical shock					P
Sample no.	OCV before test (Vdc)	OCV after test (Vdc)	Mass before test (g)	Mass after test (g)	Results
Battery #1	4.33	4.33	5.528	5.528	P
Battery #2	4.32	4.32	5.475	5.475	P
Battery #3	4.33	4.33	5.439	5.439	P
Supplementary information:					
- No fire or explosion - No rupture - No leakage - No venting					

7.3.9 TABLE: Forced internal short circuit (cells)					P
Sample no.	Chamber ambient T (°C)	OCV before test (Vdc)	Particle location ¹⁾	Maximum applied pressure (N)	Results
Samples charged at charging temperature upper limit (45°C)					
Cell #1	45	4.33	1	400	P
Cell #2	45	4.32	1	400	P
Cell #3	45	4.32	1	400	P
Cell #4	45	4.33	1	400	P
Cell #5	45	4.33	1	400	P
Samples charged at charging temperature lower limit (0°C)					
Cell #6	0	4.29	1	400	P
Cell #7	0	4.29	1	400	P
Cell #8	0	4.28	1	400	P
Cell #9	0	4.29	1	400	P
Cell #10	0	4.29	1	400	P
Supplementary information:					
¹⁾ Identify one of the following: 1: Nickel particle inserted between positive and negative (active material) coated area. 2: Nickel particle inserted between positive aluminium foil and negative active material coated area. - No fire					

D.2 TABLE: Internal AC resistance for coin cells				N/A
Sample no.	Ambient T (°C)	Store time (h)	Resistance Rac (Ω)	Results ¹⁾
Supplementary information:				
¹⁾ Coin cells with internal resistance less than or equal to 3 Ω, see test result on corresponding tables				

Attachment 1: Critical components information					P
Object / part No.	Manufacturer / trademark	Type / model	Technical data	Standard	Mark(s) of conformity ¹⁾
Cell	Anhui Youxin Intelligent Technology Co., Ltd	YQ 701335	3.8V, 345mAh	IEC 62133-2:2017, IEC 62133-2:2017/AMD 1:2021	Tested with appliance
-Positive electrode	HuNan ShanShan New Energy Co., Ltd.	LC-800D	LiCoO ₂ , PVDF, NMP, Conductive Additive	--	--
-Negative electrode	Da lian Hongguang Lithium Co., Ltd	CGP-1	Graphite, CMC, SBR, Distilled Water, Conductive Additive	--	--
-Electrolyte	ZHUHAI SMOOTHWAY ELECTRONIC MATERIALS CO., LTD.	SW-C013D	LiPF ₆ +EMC+EC+DMC, Conductivity: 9±0.5mS/cm	--	--
-Separator	Shenzhen Zhiyuan Lithium Energy Technology Co., Ltd.	9+3u	PE, 0.012mm, Shutdown temperature: 130°C	--	--
PCB	Shenzhen Lutongda Technology Co Ltd	LTD-D	V-0, 130°C	UL 796	UL E486889
Protect IC (U1)	SHEN ZHEN XIN FEI HONG ELECTRONICS CO., LTD	3016DCH	V _{CU} : 4.40±0.02V, V _{DL} : 2.80±0.05V	--	Tested with appliance
MOSFET (U2)	SHEN ZHEN XIN FEI HONG ELECTRONICS CO., LTD	8205	V _{DS} : 16V, V _{GS} : ±12V, I _b : 4.5A	--	Tested with appliance
Lead wire	Shenzhen Chenxi Electronic Co., Ltd.	3302	30AWG, 105°C, 30V	UL 758	UL approved
Tape	Interchangeable	Interchangeable	130°C	UL 510	UL approved
Supplementary information:					
¹⁾ Provided evidence ensures the agreed level of compliance. See OD-CB2039.					

Attachment 2

Photo Documentation

Product: Polymer Lithium Battery
Type Designation: YQ 701335

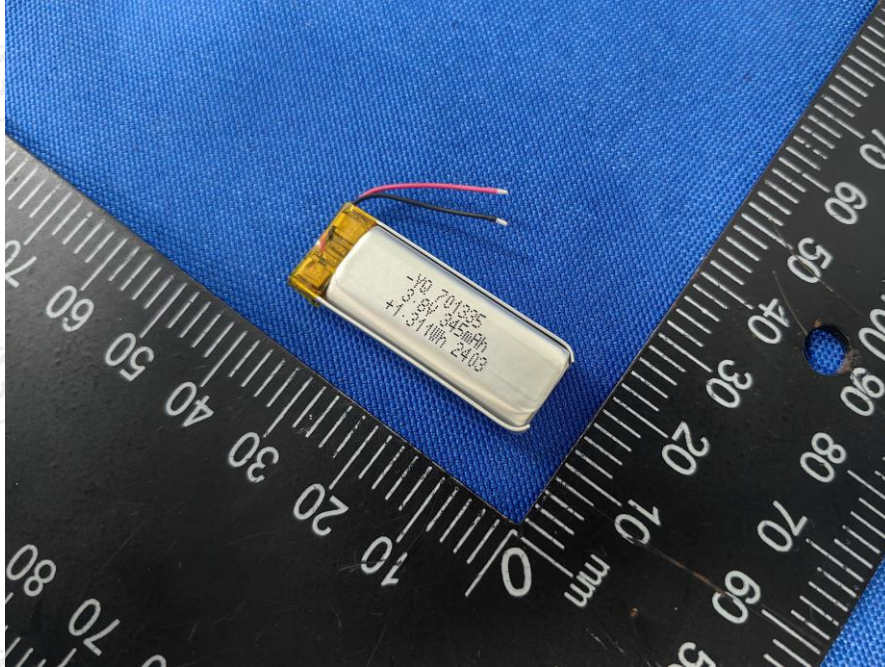

Picture 1. Battery view-1

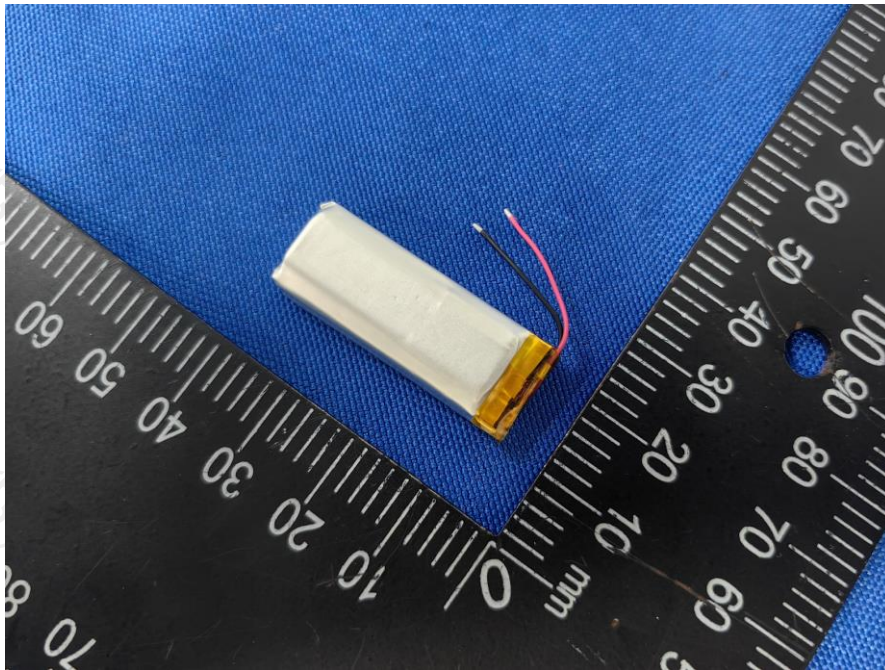

Picture 2. Battery view-2

Photo Documentation

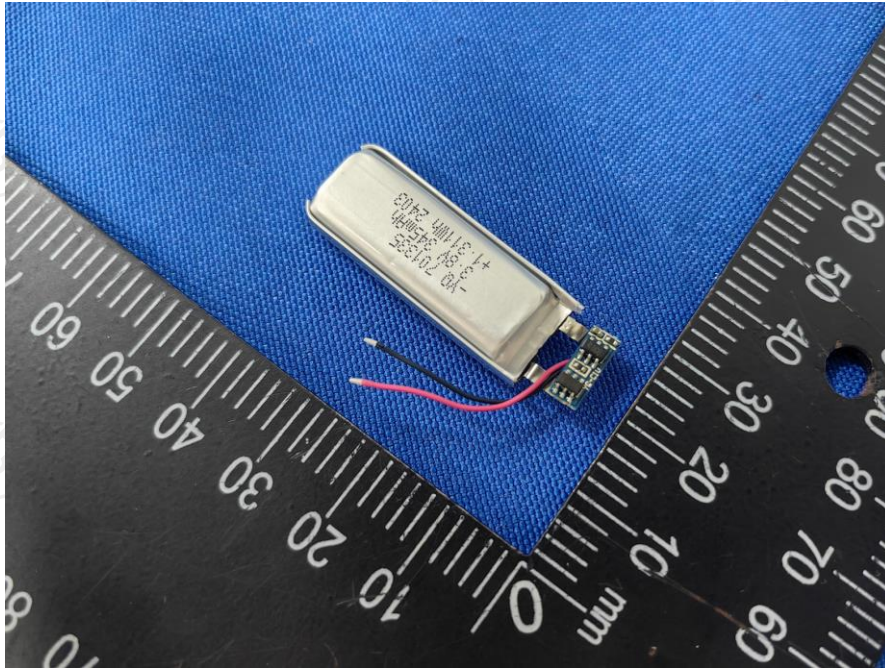

Picture 3. Battery view-3

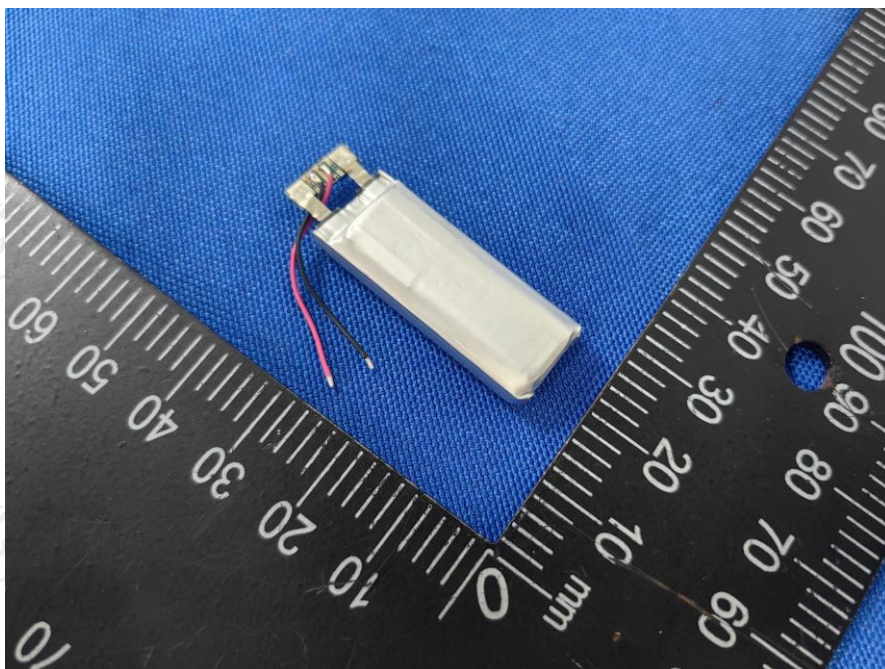

Picture 4. Battery view-4

Photo Documentation

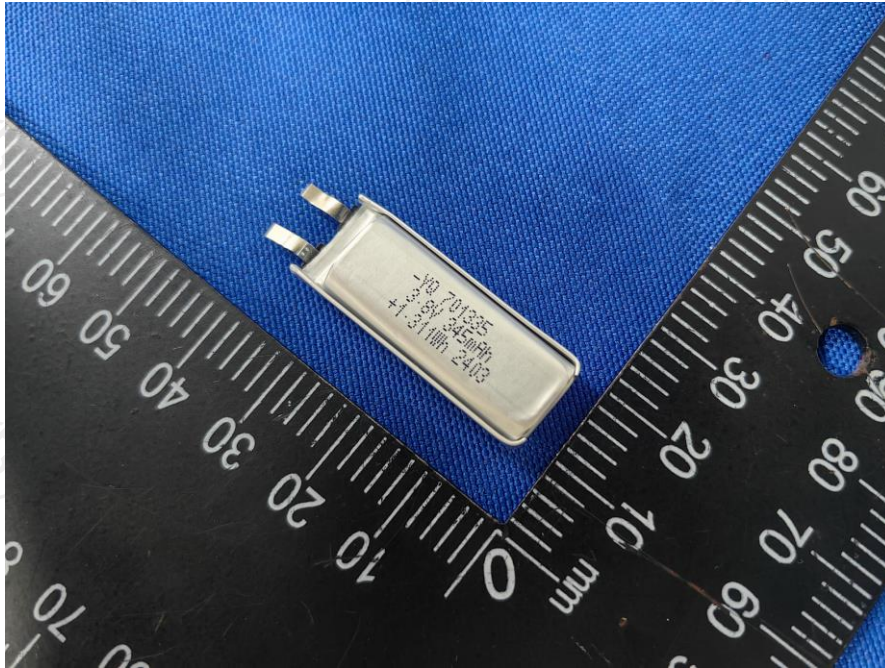

Picture 5. Cell view-1

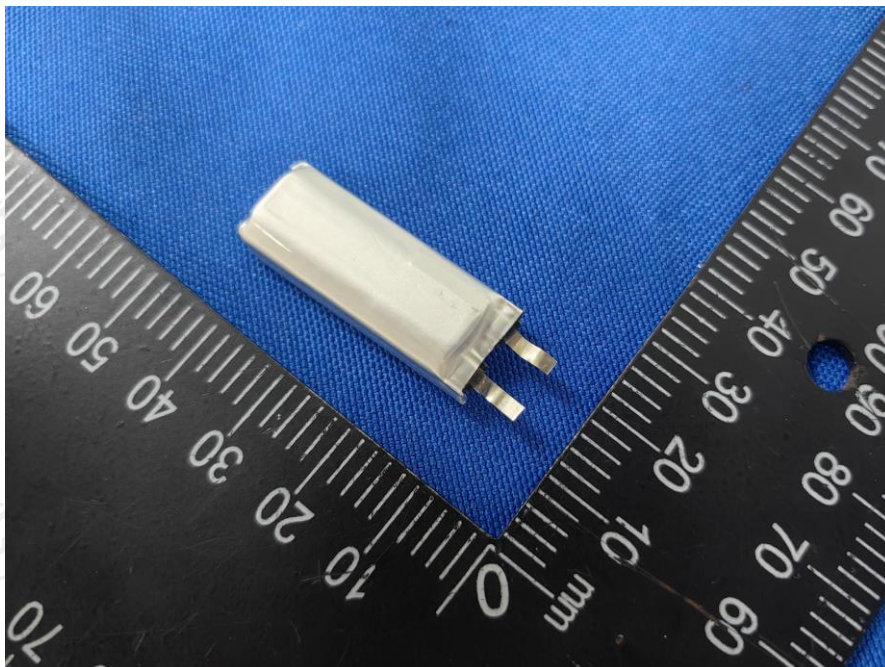

Picture 6. Cell view-2

Photo Documentation

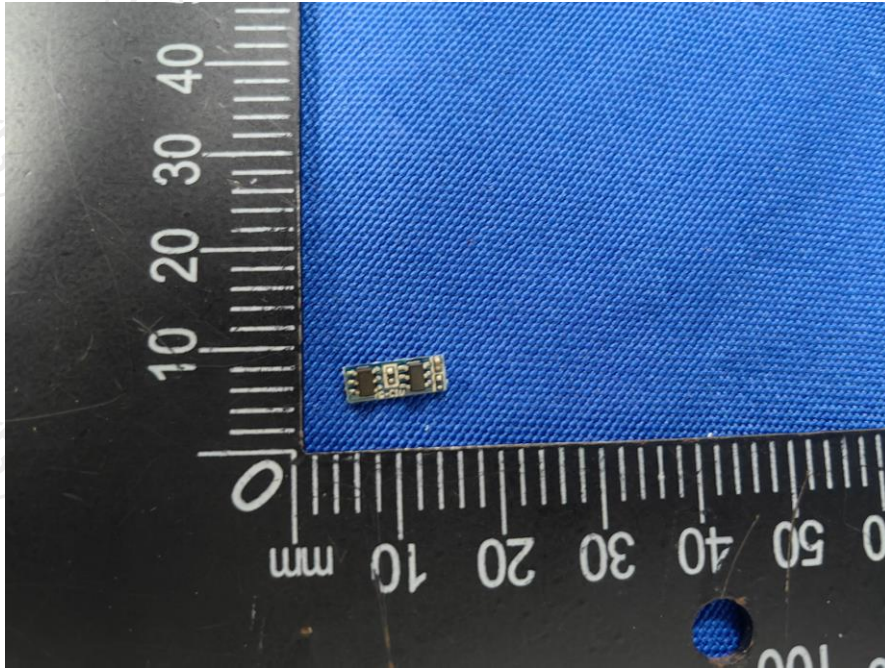

Picture 7. Protection board view-1

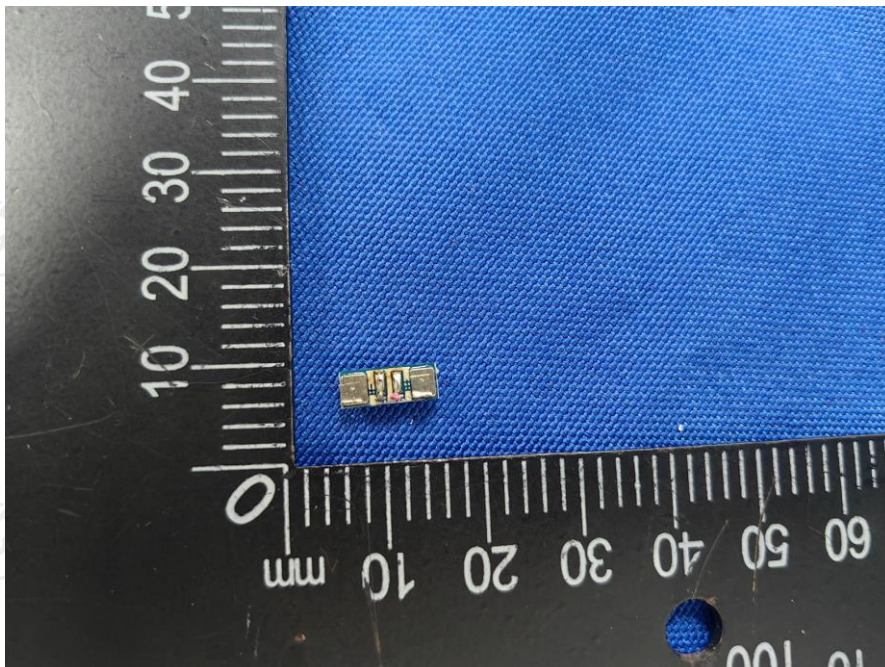

Picture 8. Protection board view-2

***** End of Test Report *****