

VIVIAN®
www.dayecorp.com

VIVIAN®

EXCLUSIVE
CUSTOMIZATION
MAKES HOME SAFER

专属定制 让家更安全

www.dayecorp.com

Our Service 我们的服务

我们遵从贴心的·尊贵的"的渠道概念，以满足和超越顾客的期望为目标，致力于向顾客提供超越期盼的全新价值。

安安每一位员工始终坚持"顾客第一"的宗旨，以一次完修为基石，提供高效率、高品质的产品和细致入微的售后服务。

We adhere to the concept of "intimate and noble" channel, to meet and exceed customer expectations as the goal, committed to providing customers beyond the expectations of the new value.

ANAN every employee always adhere to the "customer first" purpose, to a completion as the cornerstone, to provide high-efficiency, high-quality products and meticulous after-sales service.

The Business Goal 我们的宗旨

积极主动了解客户的需要，预测市场变化，
提出创新的解决方案；
运用创造性思维和先进的技术，
推陈出新，提高服务水平。

Be proactive in understanding customer needs, predicting market changes,

To propose innovative solutions;

Using creative thinking and advanced technology,

To improve service level.

Our Philosophy 我们的理念

没有完善的企业文化，没有卓越的企业价值观、企业精神和企业哲学信仰，再高明的企业经营战略也无法成功。

There is no perfect corporate culture, there is no excellent corporate values, corporate spirit and corporate philosophy, and then a sophisticated business strategy can not be successful.

HOUSE
民宅

VILLA
别墅

CLUBHOUSE
会所

世界上的事物，找不到一种一成不变的美，在瞬息万变的世界上，我们对生活的领悟更需要以一种思索的态度去面对每一件事物领会那种不同风格与意味的灵动之美。

Things in the world, can not find a fixed beauty, in the ever-changing world, our understanding of life needs to be a thinking attitude to face each thing to grasp the different style and meaning of the smart beauty.

遵循“少就是多”的设计理念，以简洁形式呈现出产品内在结构的完美，曾经让现代设计大师们迷醉的风格，在这里一脉相传。

Following the design concept of "less is more", it presents the perfect internal structure of the product in a concise form. The style that once fascinated modern design masters is passed down here.

揉合了西方审美哲学中的简约之美，体现着一种专业精神而彰显出来的成就感和创造力，给你的不只是产品，不只家居组合、而是一种感觉，一种标准，更是一种时尚标杆。

Combining the beauty of simplicity in Western aesthetic philosophy, it embodies a sense of accomplishment and creativity that is demonstrated by a professional spirit. It gives you not only products, not only home furnishings, but also a feeling, a standard, and even more. A fashion benchmark.



HOTEL
酒店

BUILDING
楼宇

ENGINEERING
工程

可以像艺术品，具有内涵，质感在空间中脱颖而出，以任何角度欣赏都惊奇的发现，他独具一格，耐人寻味，自然、简单、时尚之美，由此扩展到生活的每一天。

It can be like a work of art, with connotation and texture that stand out in the space. It is surprising to find it from any angle. He is unique, intriguing, natural, simple, and stylish, which extends to every day of life.

现代主义的独特风格，卓越的设计大方中透着灵气，自然中蕴藏尊贵，极大地满足了舒适、实用、审美三方面要求，给你一个清雅、浪漫、休闲环境。

The unique style of modernism, the excellent design and generosity reveal the spirit, and the nobleness in nature, which greatly meets the requirements of comfort, practicality and aesthetics, and gives you an elegant, romantic and leisure environment.

简约主义就是把设计简化到它的本质，强调它的内在的魅力，在这种充满冷调的现代与未来交织的情境中，会由简单而产生出理性、秩序和专业感。

Minimalism is to simplify the design to its essence, emphasizing its inherent charm. In this cold-toned environment where modernity and the future are intertwined, simplicity will produce rationality, order and professionalism.



VIVIAN[®]

VIVIAN产品一直以“好品质，创未来”为宗旨，以“诚信、品质、共进”为发展理念，一直在追求“品质为先，质量第一，”。

多年来，VIVIAN凭借过硬的质量、良好的信誉、优质的服务、合理的价格不断拓展市场。目前，产品50多种规格、5个品种，护角网、批荡网、砖带网、有筋扩张网、模板网、等系列产品，不仅畅销全国30多个省、市、自治区，还远销亚太地区、欧美、东南亚、泰国、日本、英国、台湾、新加坡、马来西亚、印度尼西亚、非洲等20多个国家和地区，公司始终坚持：“诚信经营、互惠互利”的原则，在国际行业市场中，倍受青睐，创造了一个又一个骄人的业绩，VIVIAN将立足于中国，迈向国际市场大舞台。

引进世界先进织网设备及技术，经自主研发，先后获得实用新型，外观设计，国家专利技术20多项，成功研发了多项新技术填补了行业空白，秉承“为实为适、唯新唯美”的经营理念，高度重视产品质量和品牌形象，VIVIAN在1997年率先通过了ISO9001:2000国际质量体系认证、ISO14001环境管理体系认证，SGS认证,CE认证，ICC认证，产品严格按照中华人民共和国GB-5330标准检验，并全面导入CIS品牌形象。

天道酬勤，人道酬善，商道酬信，通过我们自身不断努力，以诚信立企、以人为本，VIVIAN坚持技术创新化、管理科学化、产业规模化，不断完善企业内部管理制度，为打造世界名牌而不懈努力，面对新世纪，再创辉煌。

VIVIAN缔造者信心百倍地迎接挑战。“天道酬勤，踏实进取”的企业理念，一直激励着全体成员勇往直前。更快、更强、更辉煌!!!

VIVIAN products have been "good quality, create the future" for the purpose, to "integrity, quality, progress" for the development concept, has been the pursuit of "quality first, quality first."

Over the years, VIVIAN with excellent quality, good reputation, quality service, reasonable prices continue to expand the market. At present, the products have more than 50 specifications, 5 varieties, corner protector net, batch swing net, brick belt net, reinforcement expansion net, template net, and other series of products, not only sell well in more than 30 provinces, cities and autonomous regions, but also exported to more than 20 countries and regions in the Asia-Pacific region, Europe and the United States, Southeast Asia, Thailand, Japan, Britain, Taiwan, Singapore, Malaysia, Indonesia, Africa, etc. The company always adhere to the principle of "integrity management, mutual benefit", in the international industry market, much favored, created one after another impressive performance, VIVIAN will be based in China, towards the international market stage.

The introduction of the world's advanced weaving equipment and technology, through independent research and development, has obtained utility model, appearance design, national patent technology more than 20, successfully developed a number of new technologies to fill the gaps in the industry, adhering to the "practical and suitable, new and beautiful" business philosophy, attaches great importance to product quality and brand image, VIVIAN took the lead in 1997 through the ISO9001:2000 international quality system certification, ISO14001 environmental management system certification, SGS certification, CE certification, ICC certification, products in strict accordance with the People's Republic of China GG-5330 standard inspection, and fully introduced the CIS brand image.

God rewards the diligent, humane reward good, business reward letter, through our own continuous efforts, in good faith, people-oriented, VIVIAN adhere to technological innovation, scientific management, industrial scale, and constantly improve the internal management system of the enterprise, in order to create a world famous brand and make unremitting efforts in the face of the new century, to create brilliance.

The founders of VIVIAN met the challenge with confidence. The corporate philosophy of "God rewards the diligent, steadfast and enterprising" has been inspiring all members to go forward. Faster, stronger, more brilliant!!





V-001



V-002

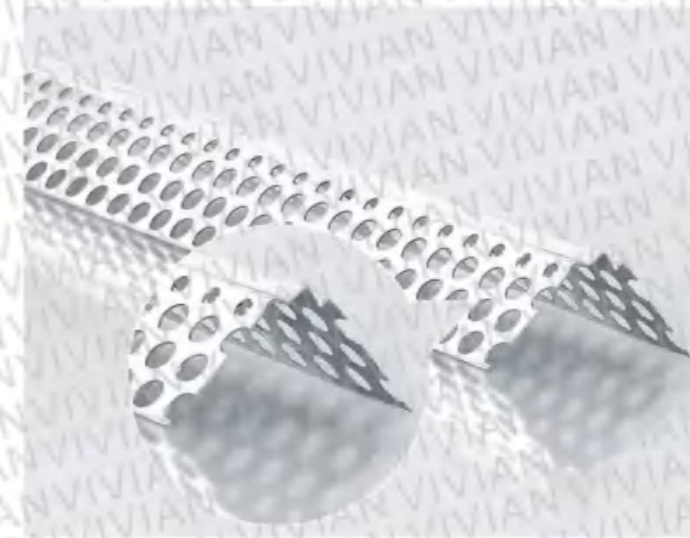

V-007

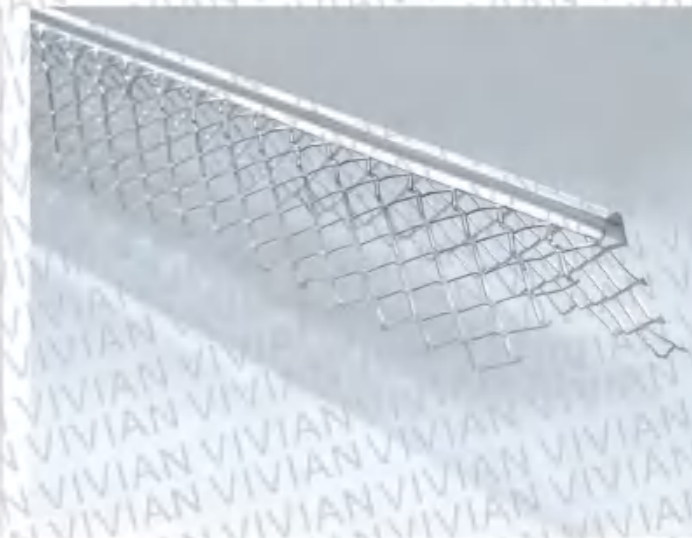

V-008



V-003



V-004



V-009



V-010

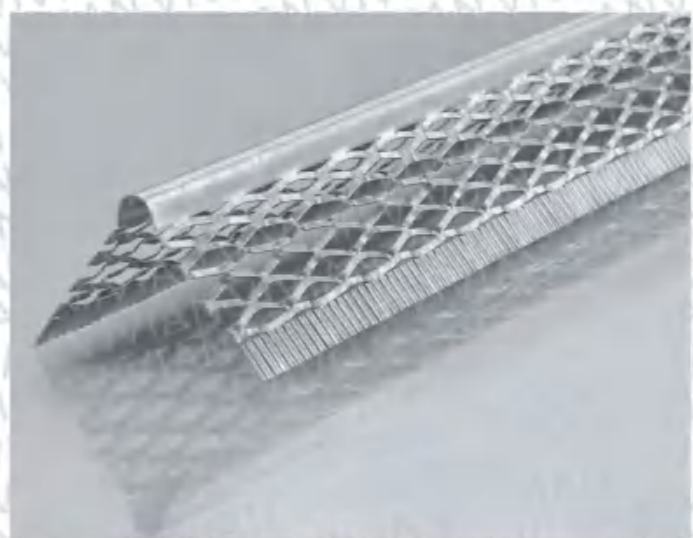

V-005

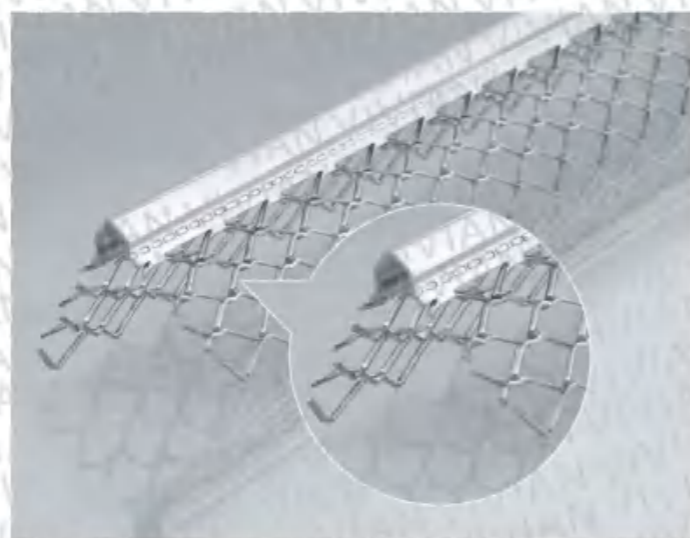

V-006

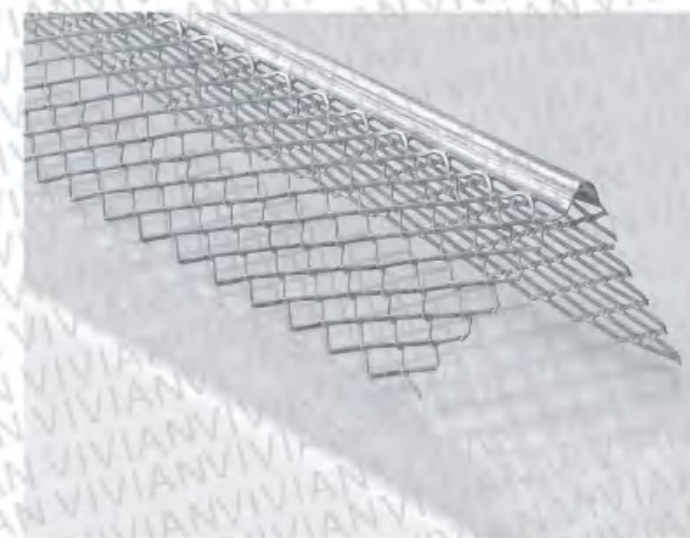

V-011



V-012



V-013

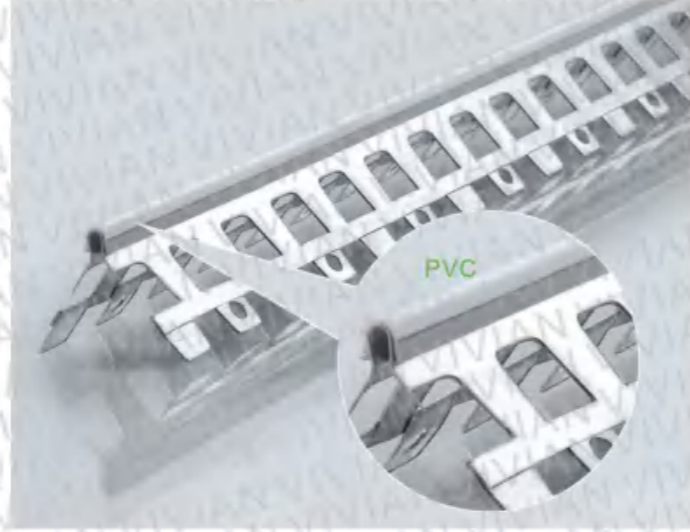

V-014



V-015



V-016



V-017



V-018

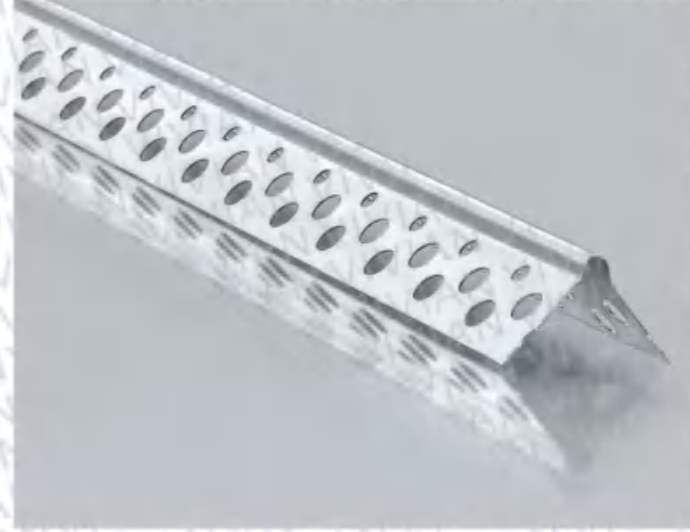

V-019

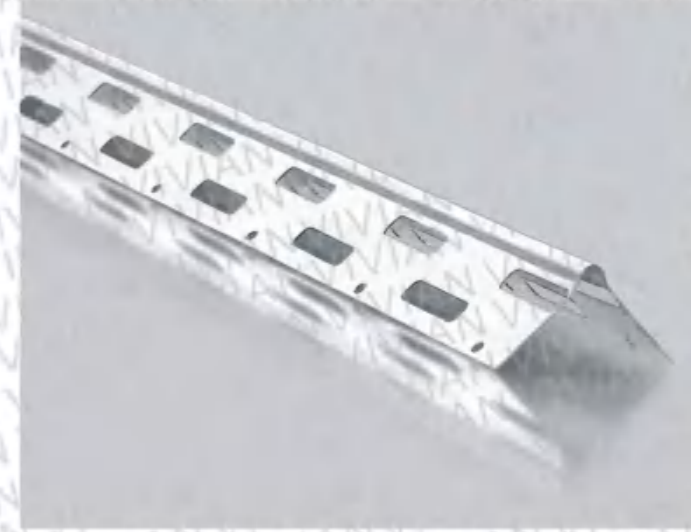

V-020

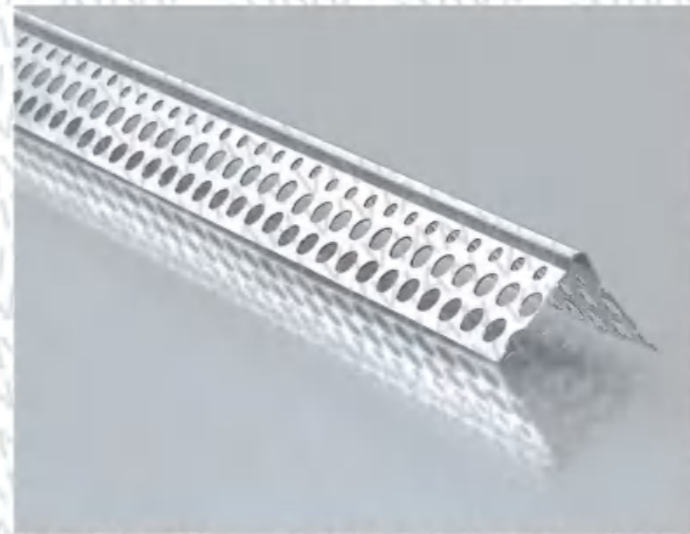

V-021

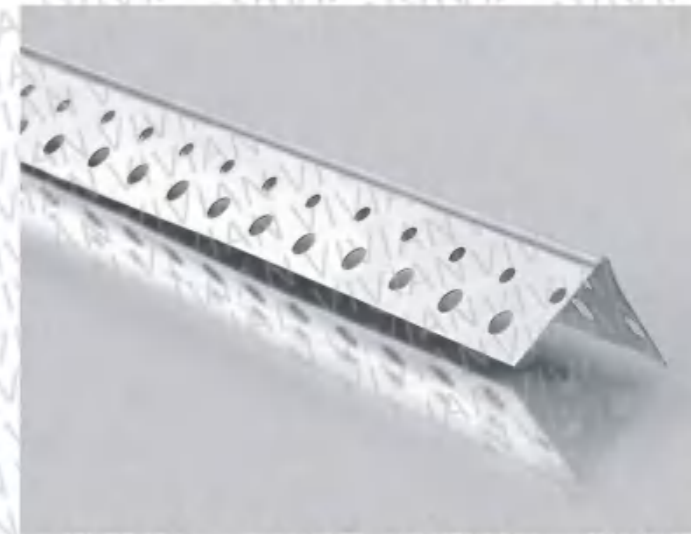

V-022

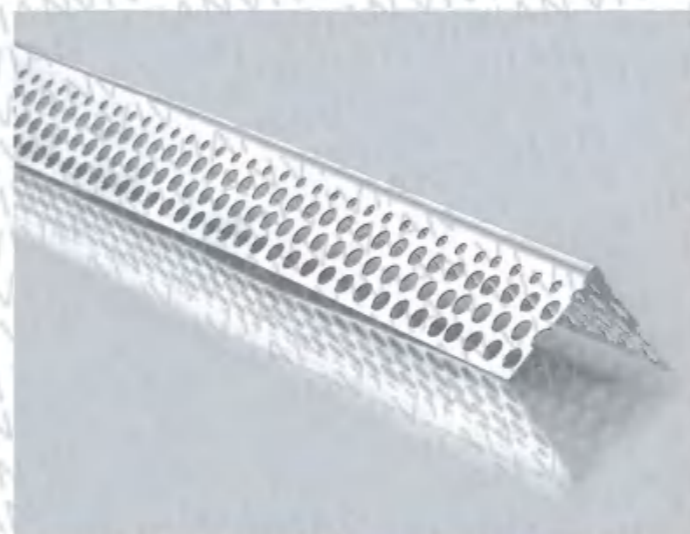

V-023

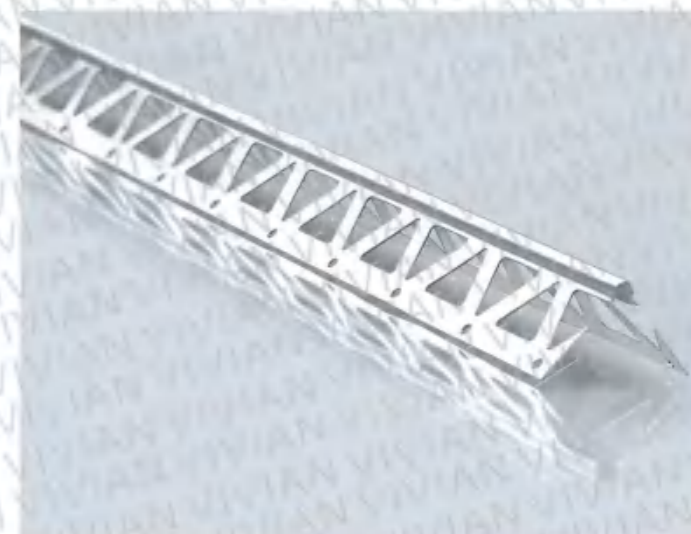

V-024



V-025



V-026



V-031

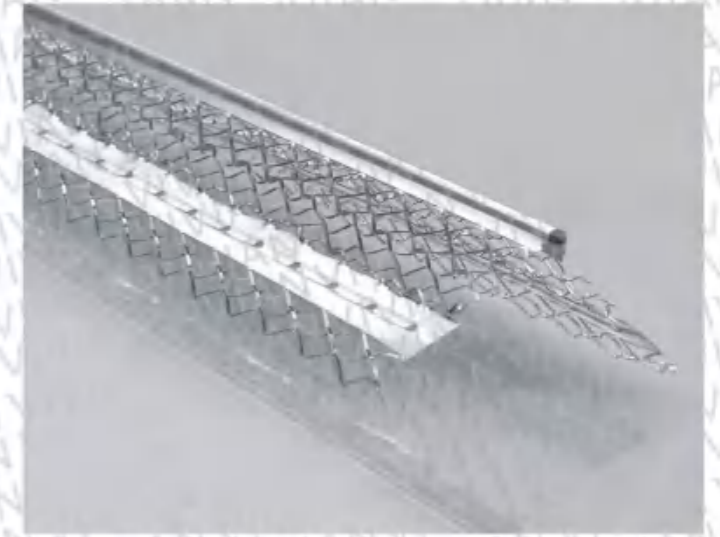

V-032



V-027

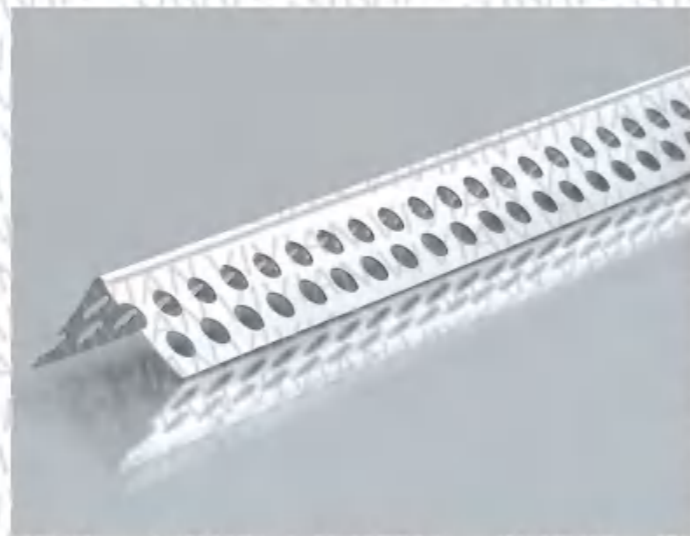

V-028



V-033



V-034



V-029



V-030



V-035



V-036



V-037

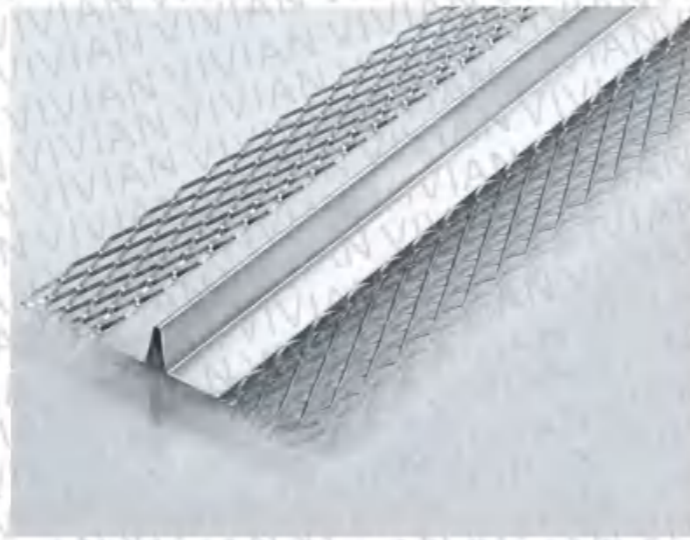

V-038



V-039



V-040



V-041



V-042



V-043



V-044



V-045

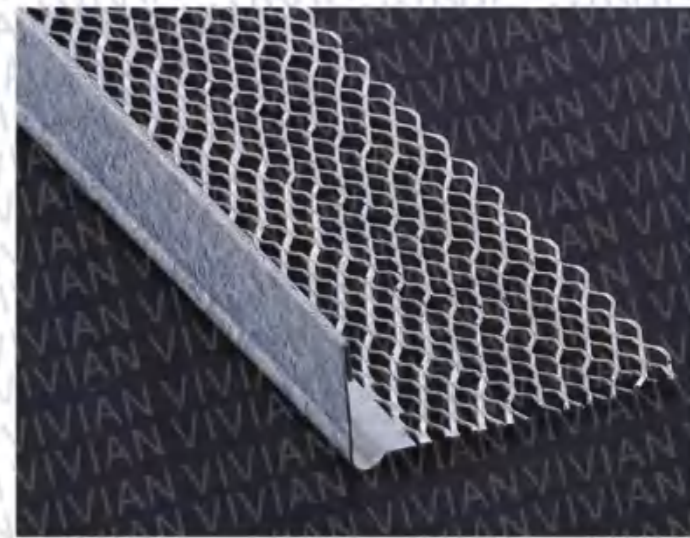

V-046



V-047

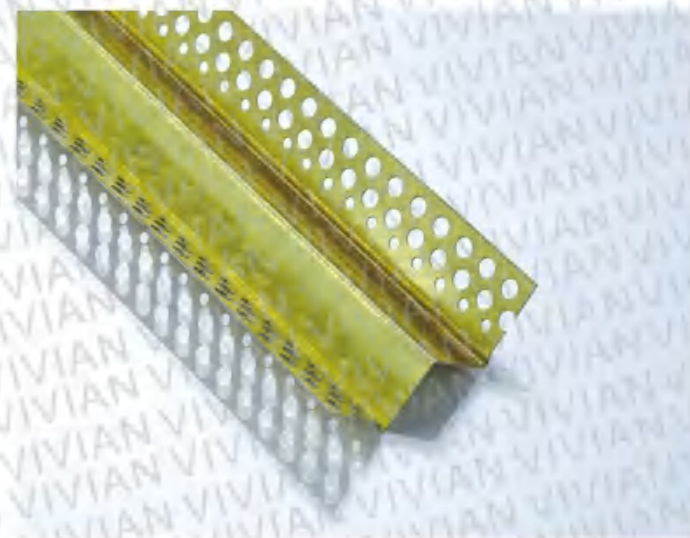

V-048



V-049



V-050



V-051



V-052

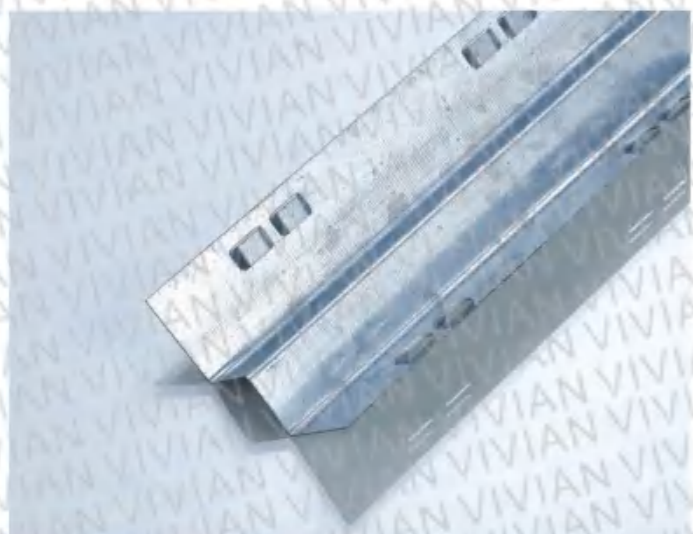

V-053

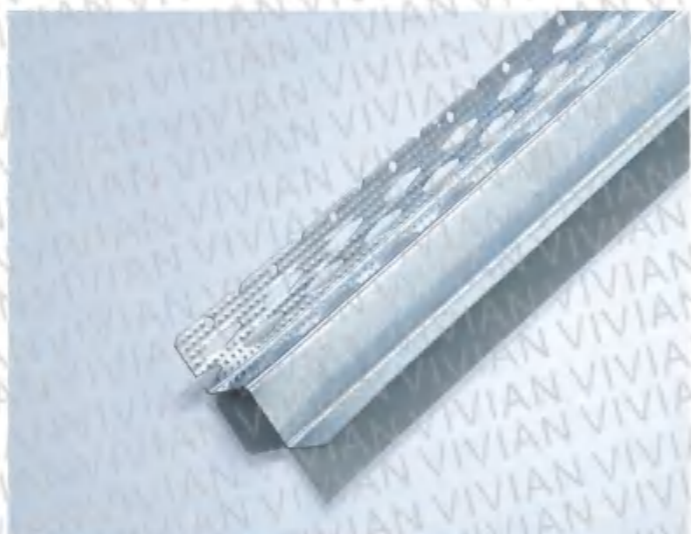

V-054



V-055



V-056



V-057



V-058



V-059



V-060

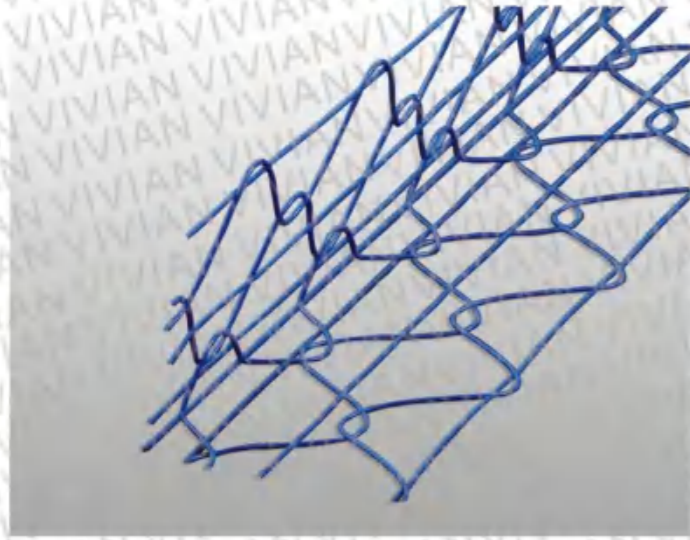

V-061

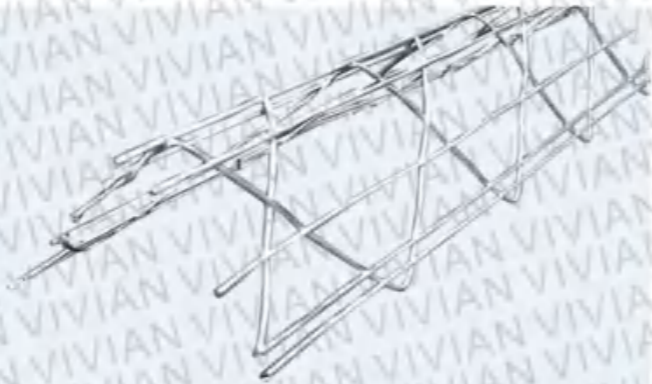

V-062

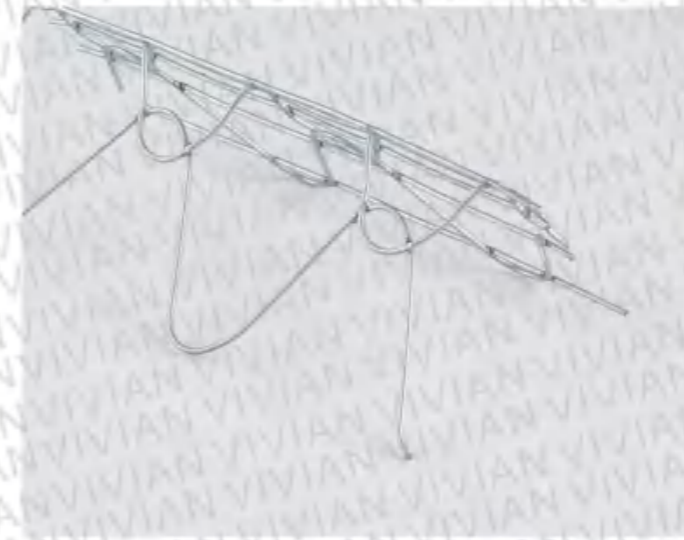

V-067

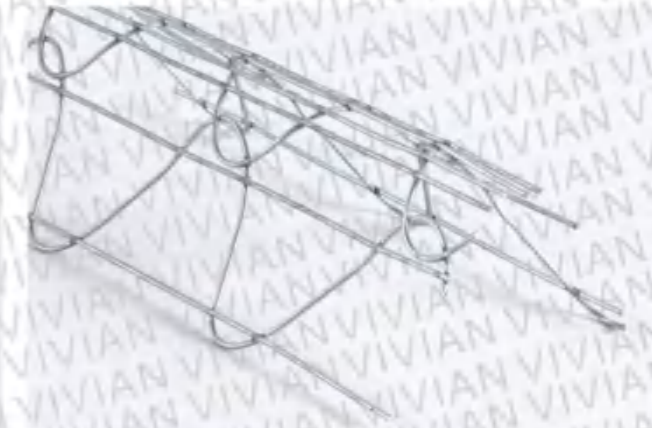

V-068

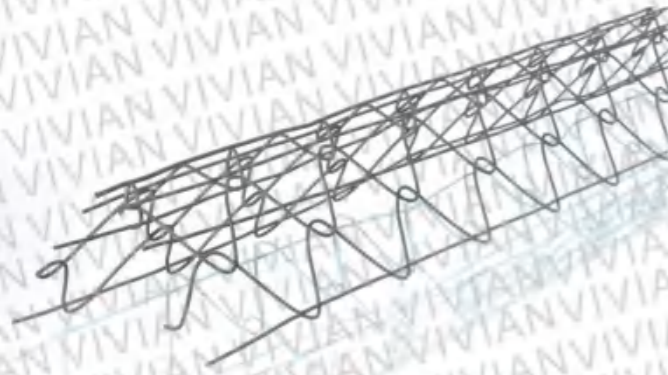

V-063

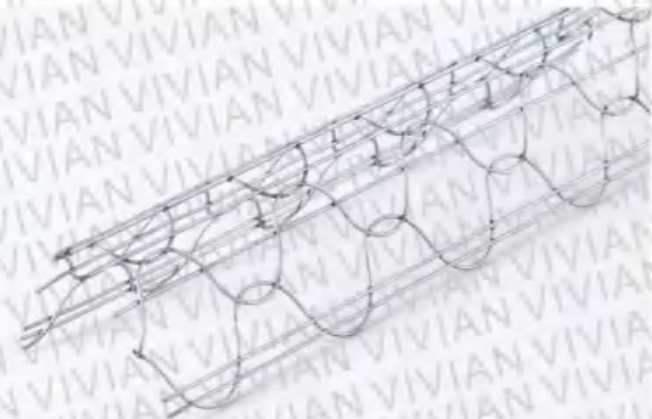

V-064



V-069

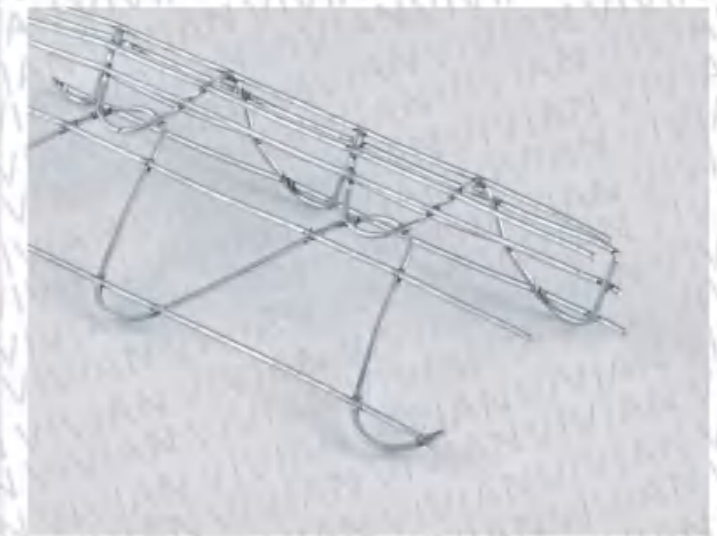

V-070



V-065

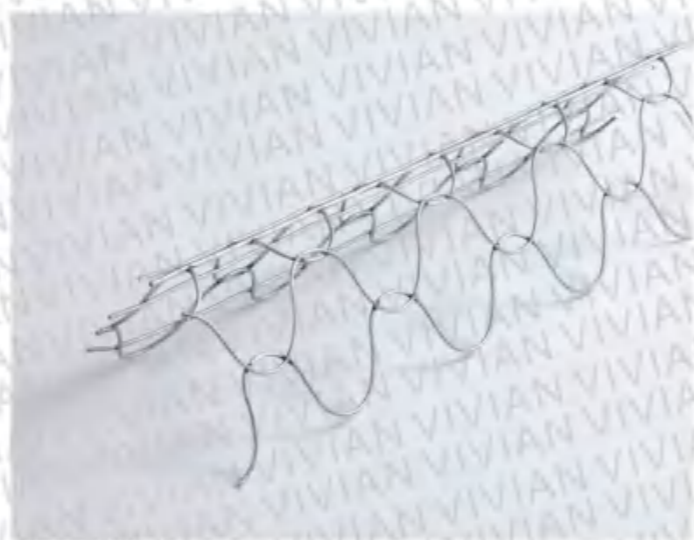

V-066

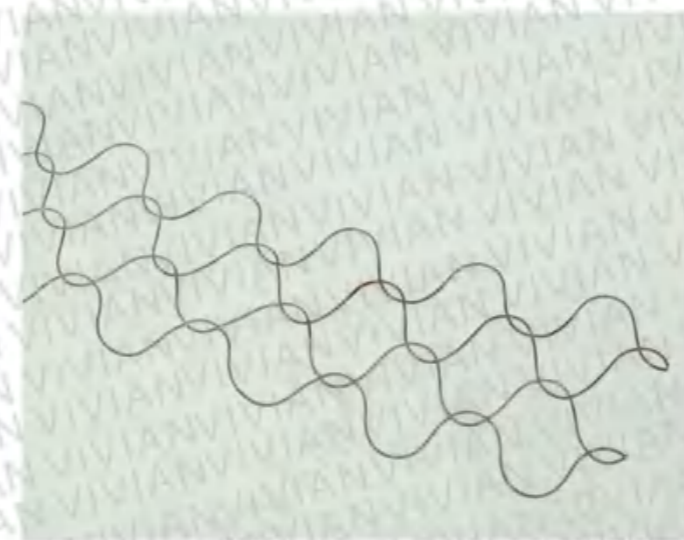

V-071

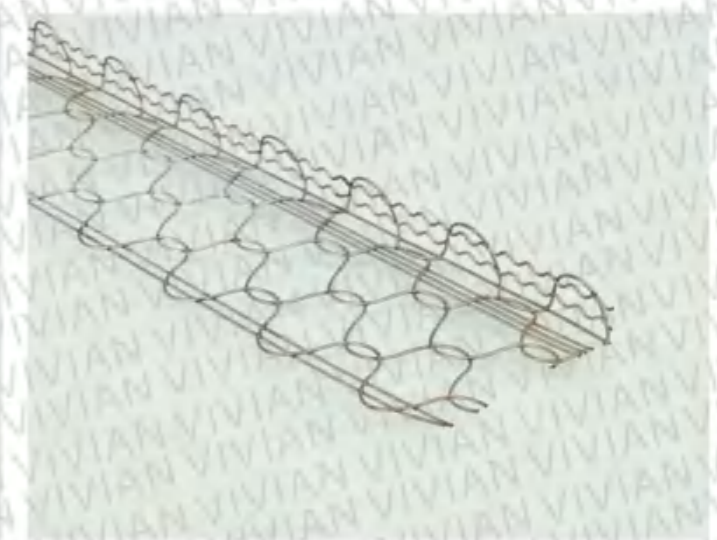

V-072



V-073



V-074



V-079



V-080



V-075



V-076



V-081



V-082



V-077

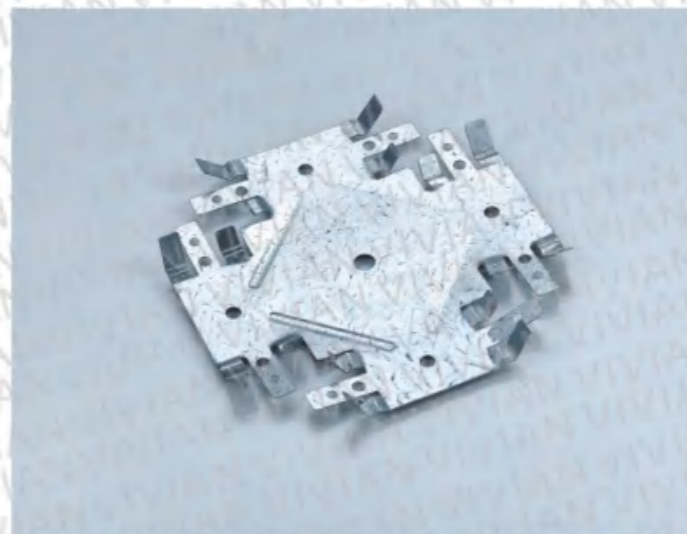

V-078



V-083

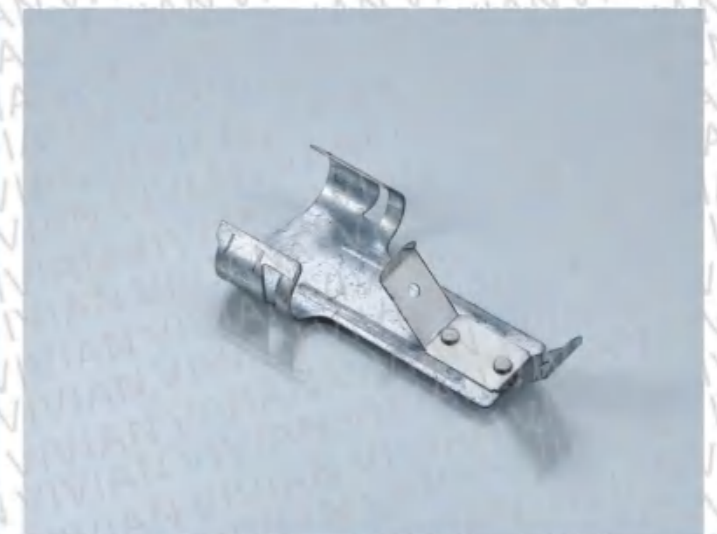

V-084



V-085



V-086



V-087



V-088



V-089



V-090



V-091



V-092



V-093

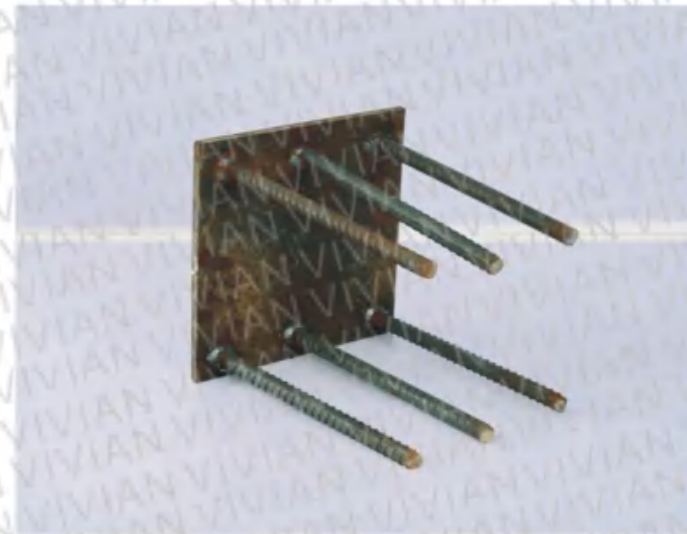

V-094



V-095



V-096



V-097



V-098



V-099

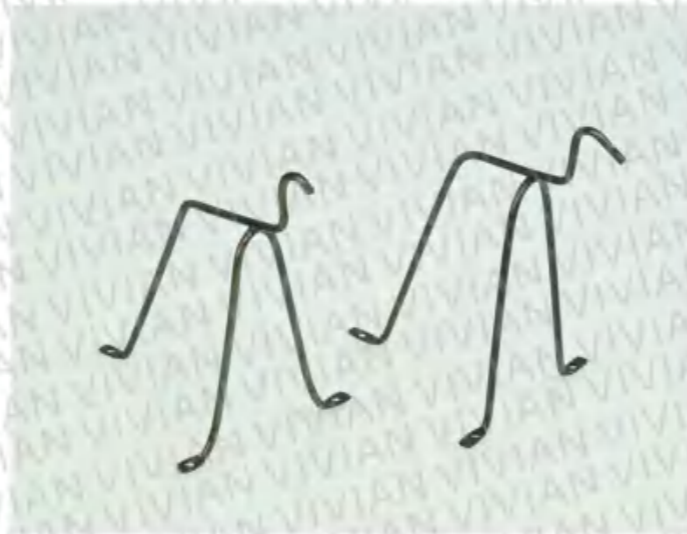

V-100

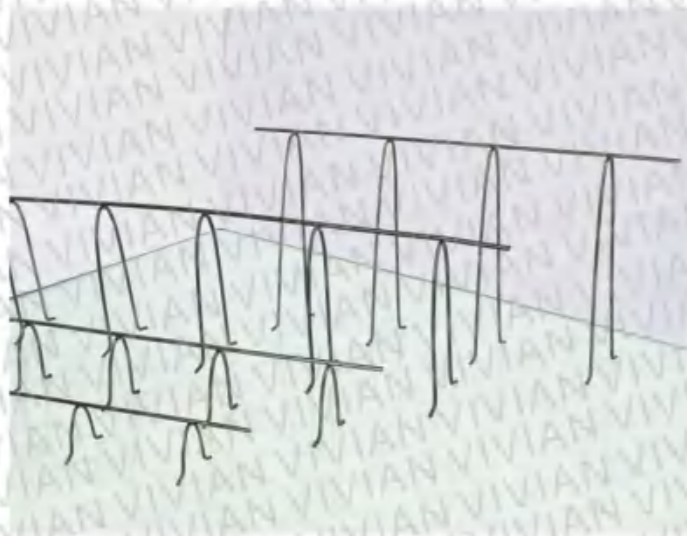

V-101

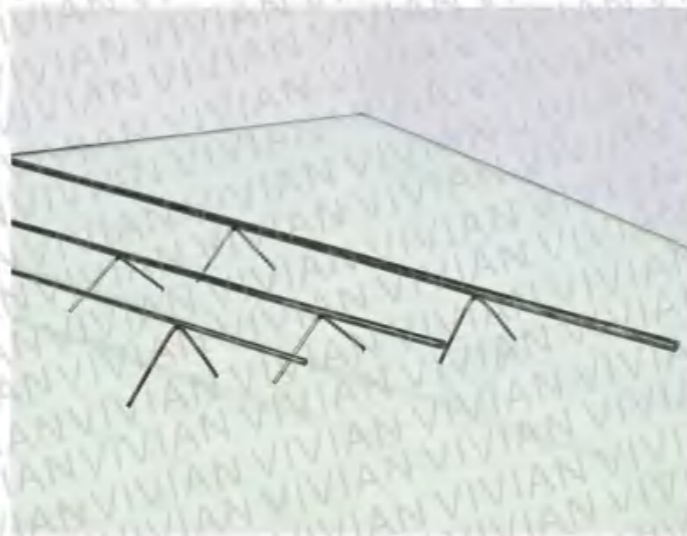

V-102

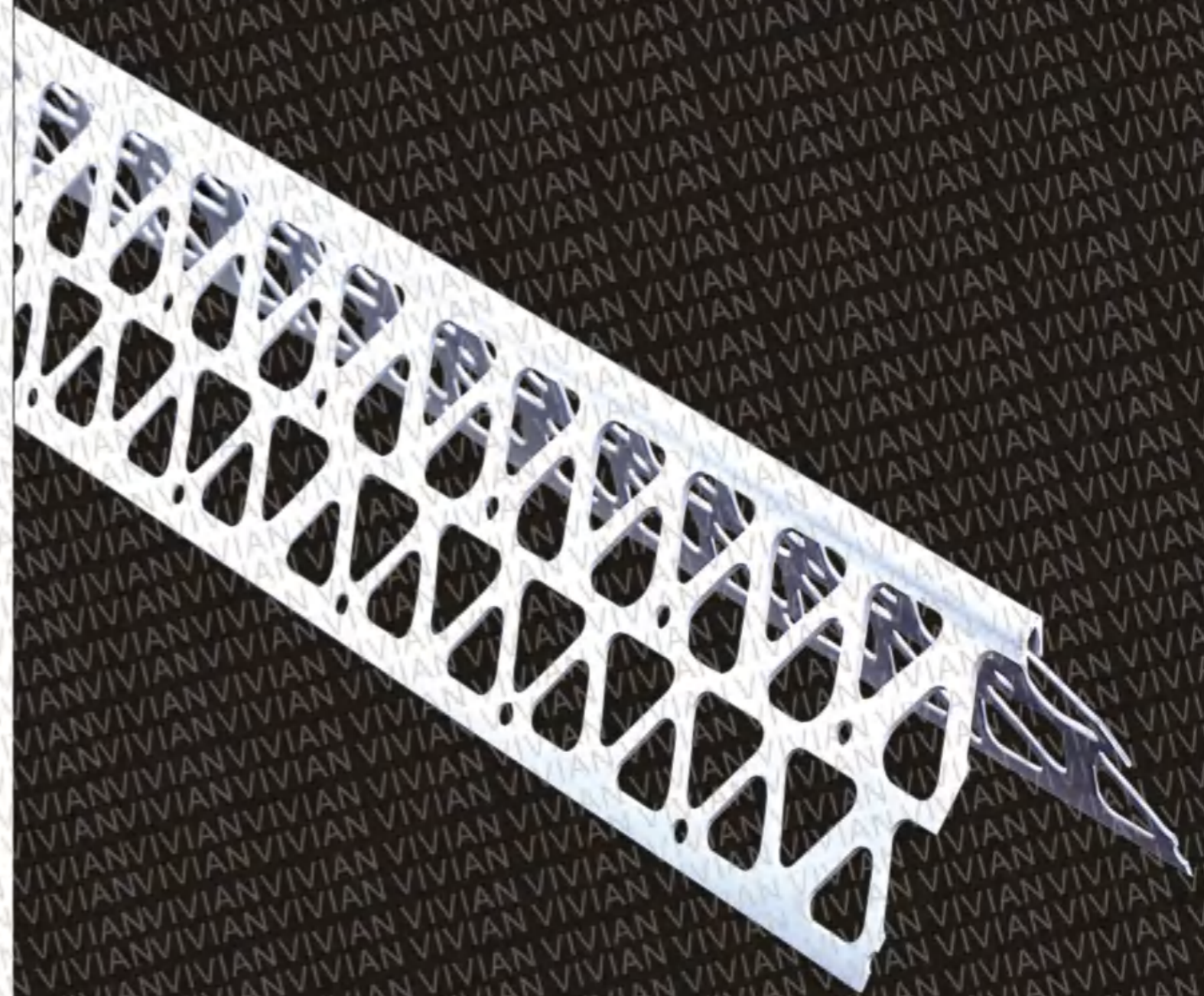



V-103



V-104



V-105



V-106



V-107



V-108



V-109



V-110



V-111



V-112

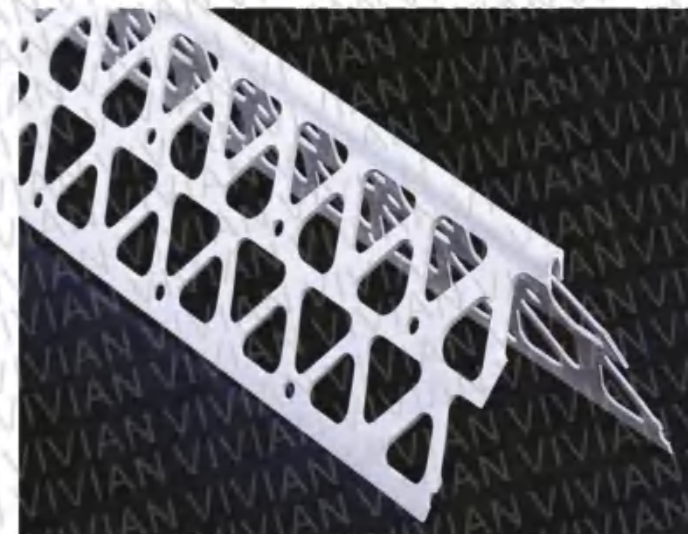

V-113



V-114



V-115



V-116



V-117



V-118



V-119



V-120



V-121



V-122



V-123



V-124



V-125



V-126



V-127



V-132

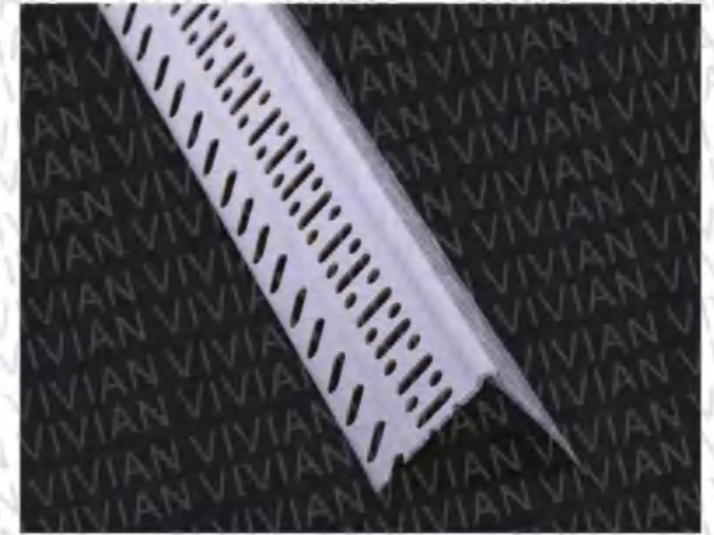

V-133



V-128



V-129



V-134



V-135



V-130



V-131



V-136



V-137



V-138



V-139



V-144



V-145



V-140



V-141

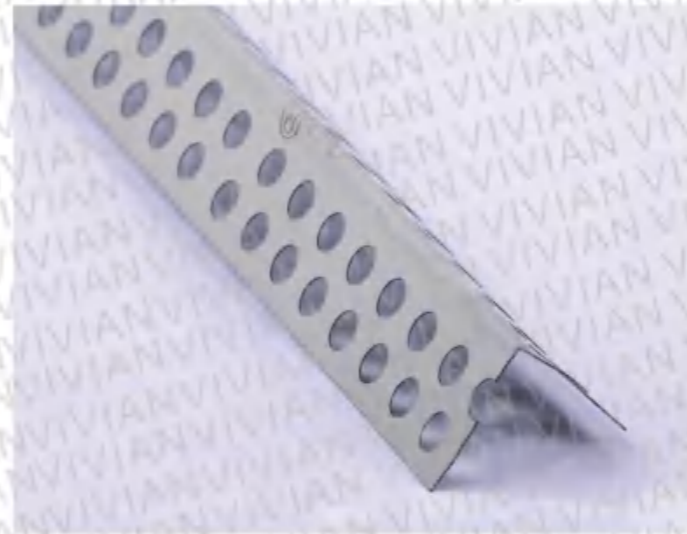

V-146

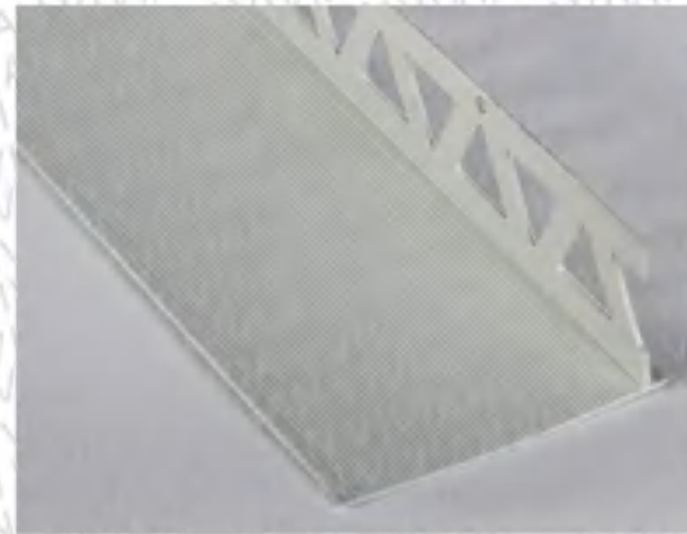

V-147



V-142



V-143



V-148



V-149



V-150



V-151



V-152



V-153



V-154



V-155

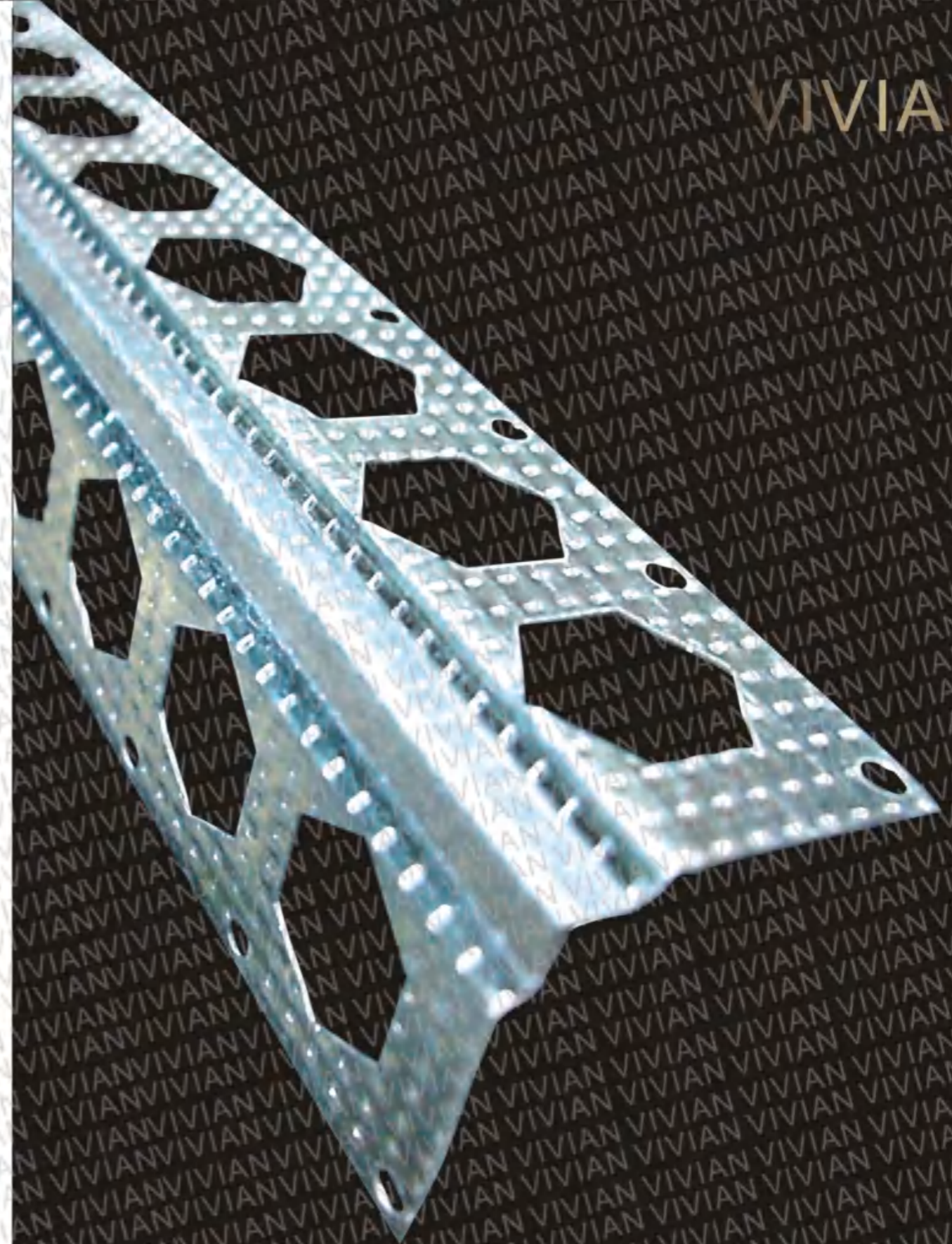



V-156



V-161

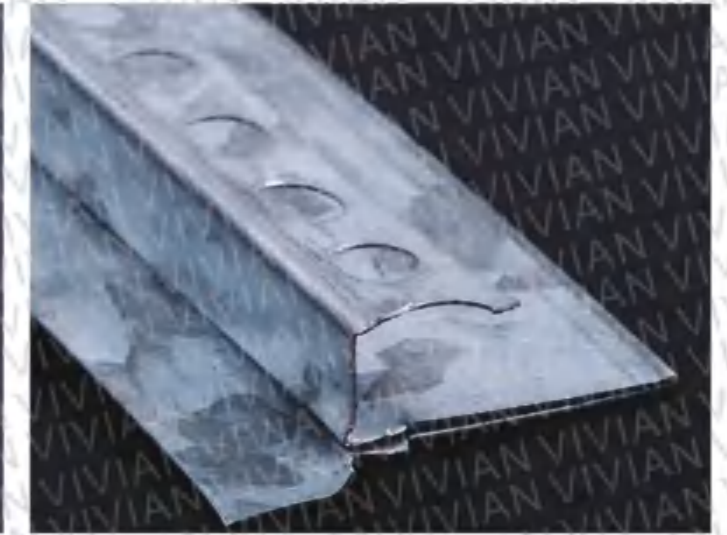

V-162



V-157



V-158



V-163



V-159



V-160



V-164

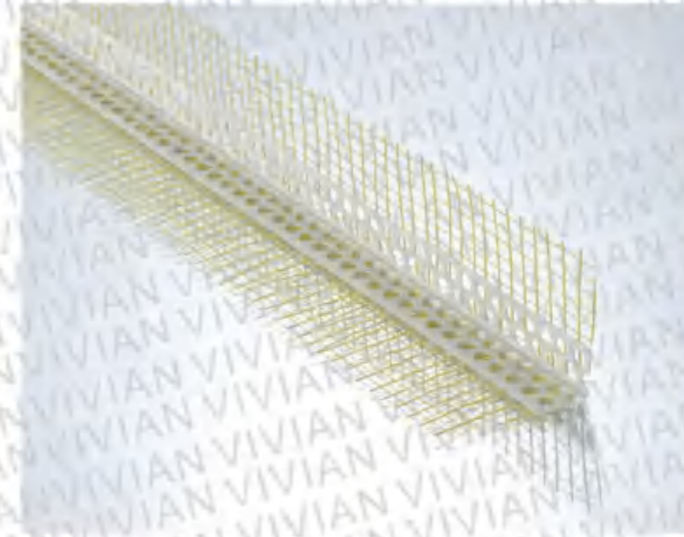
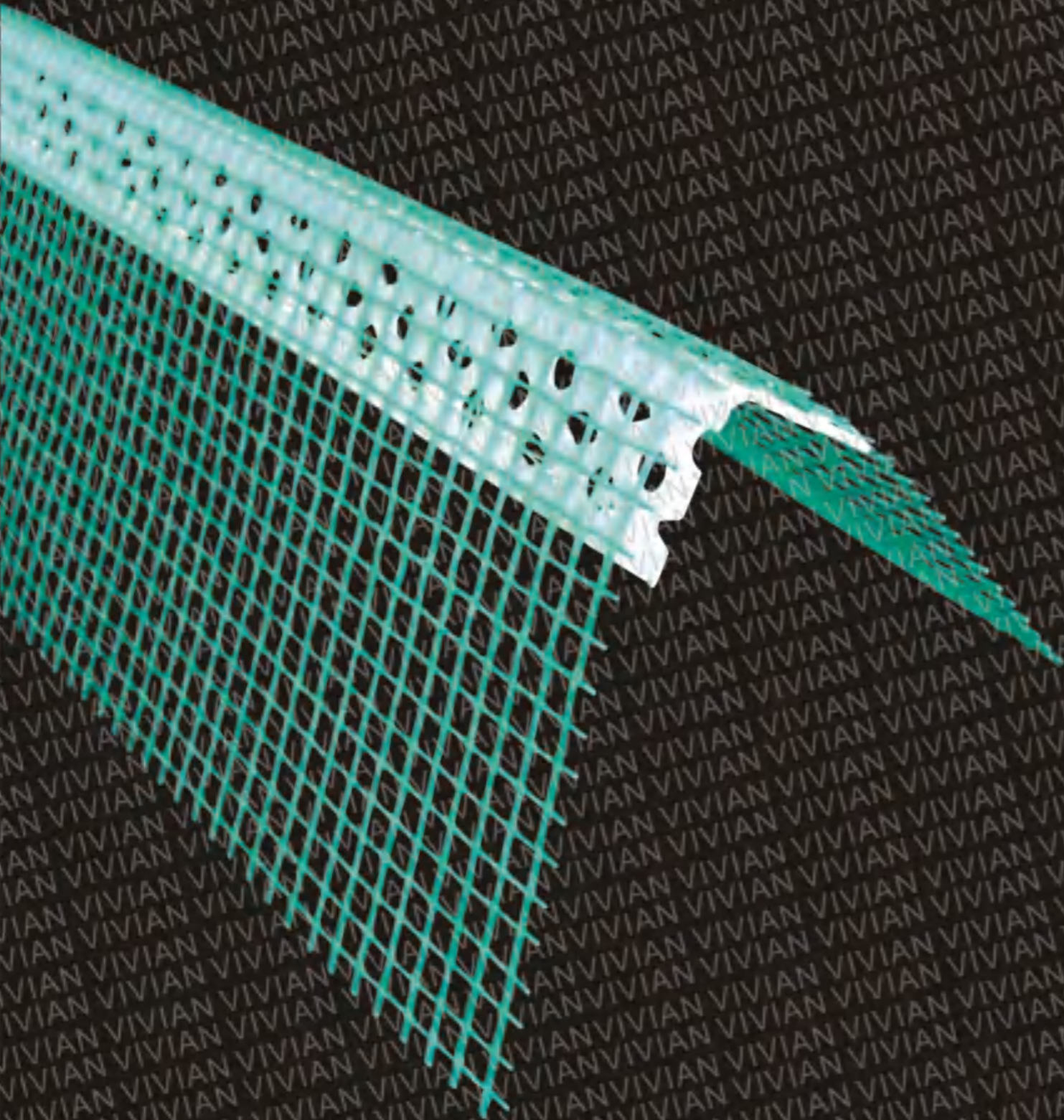

V-165

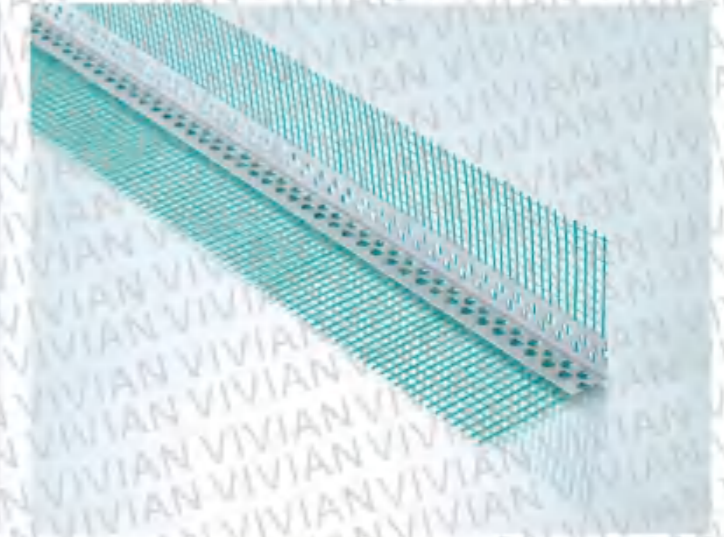

V-166



V-167



V-168

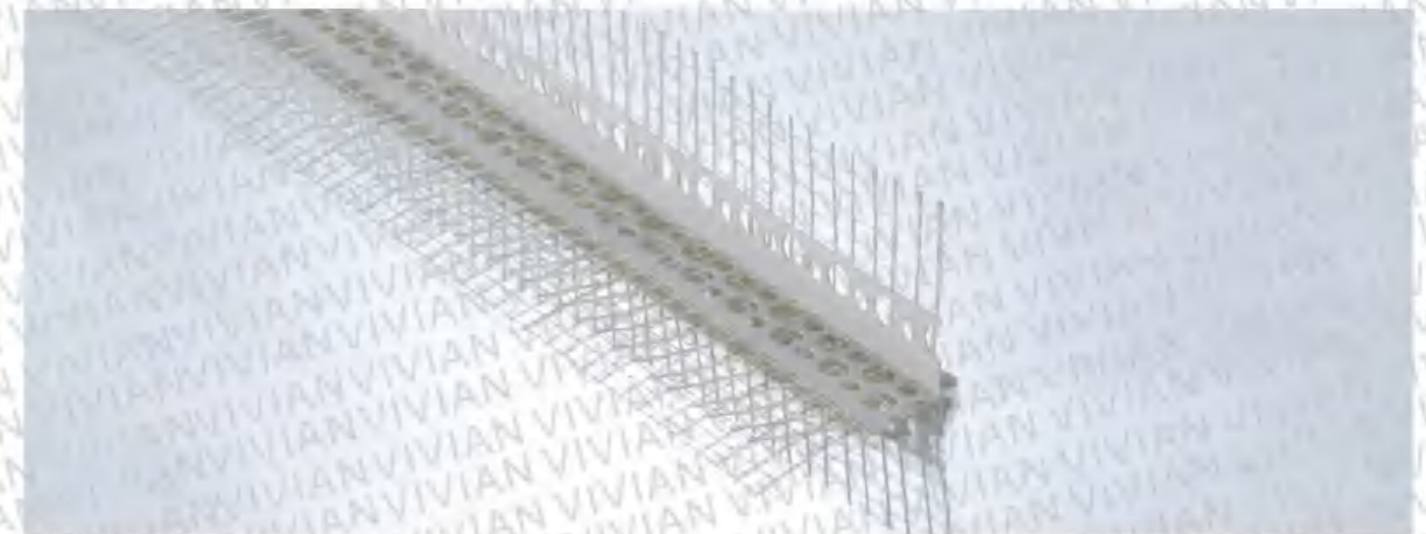

V-169

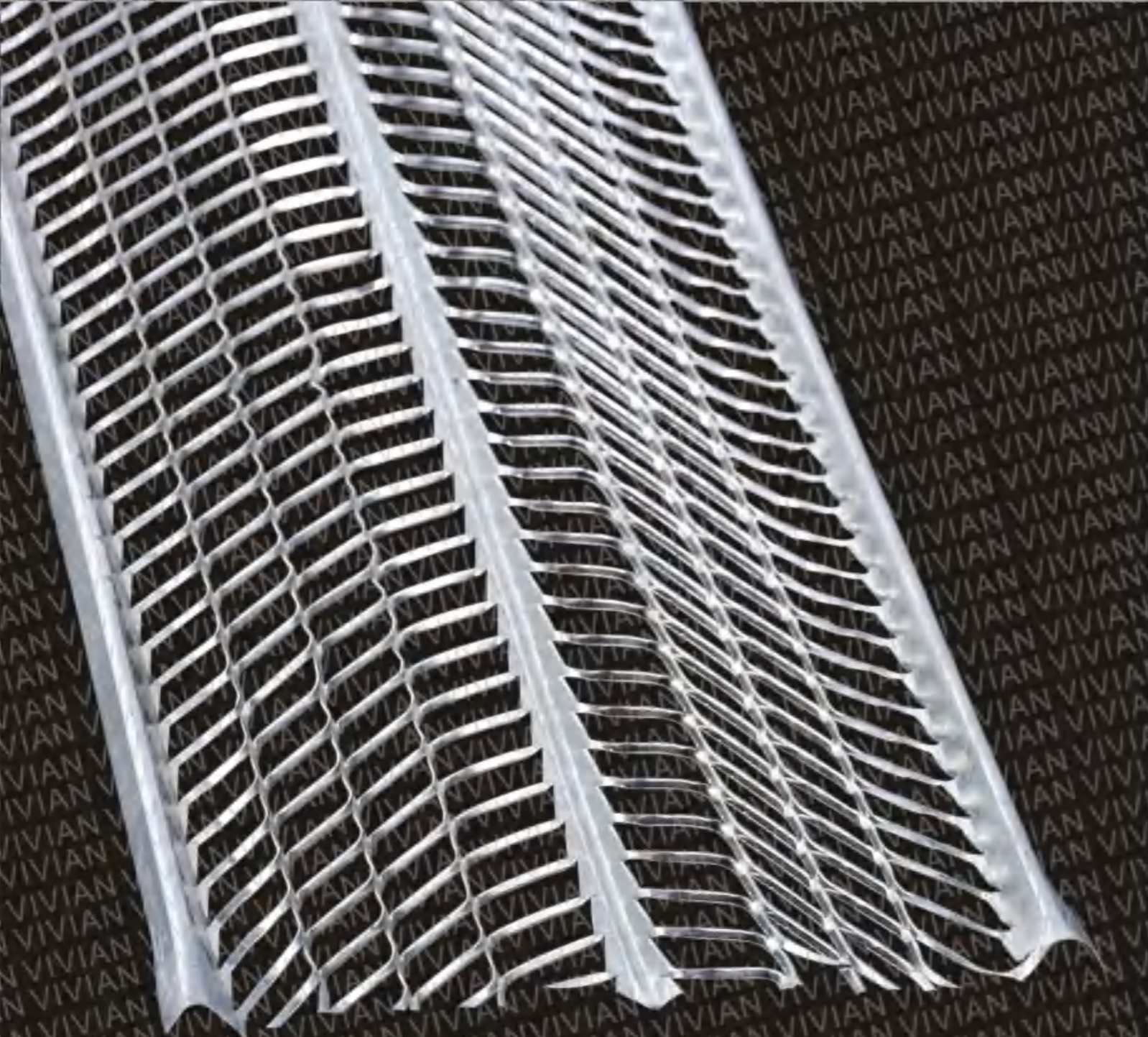

VIVIAN®

VIVIAN®

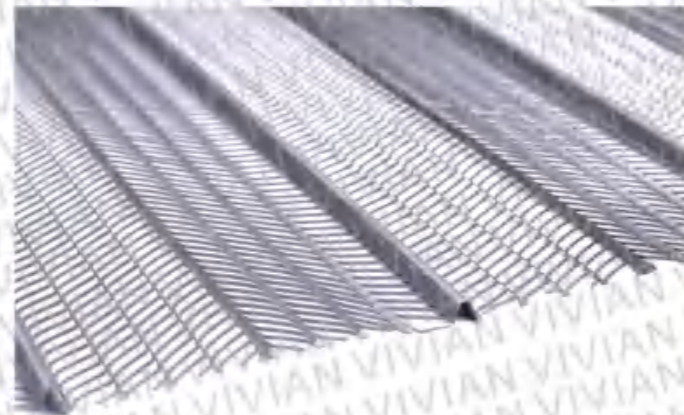

V-170



V-171

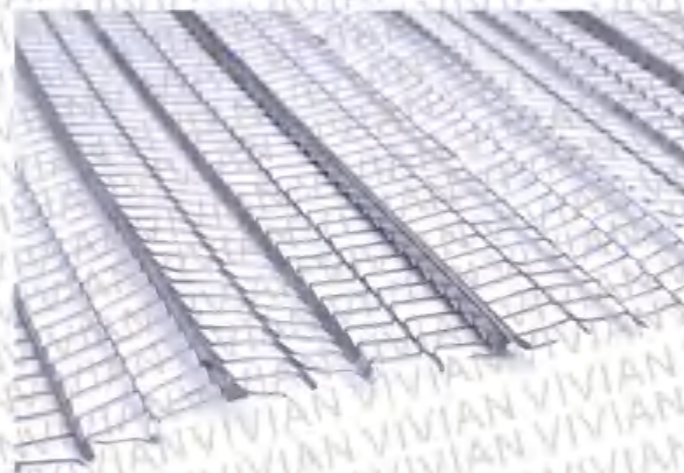

V-172



V-173



V-174



V-175



V-176



V-177



V-178

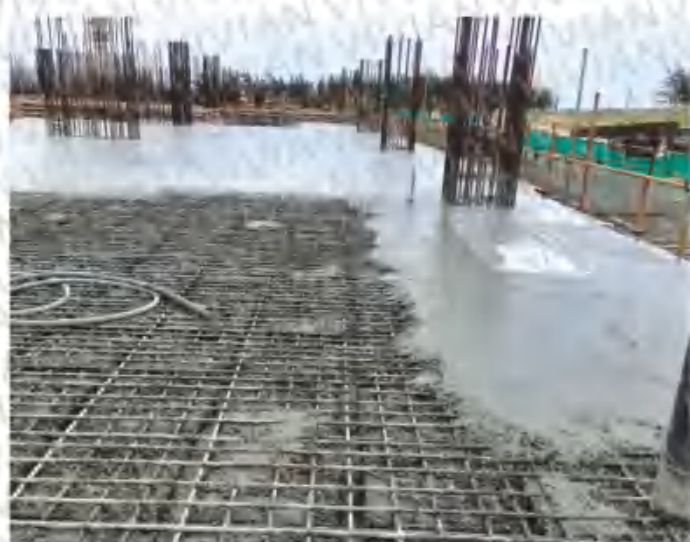

V-179

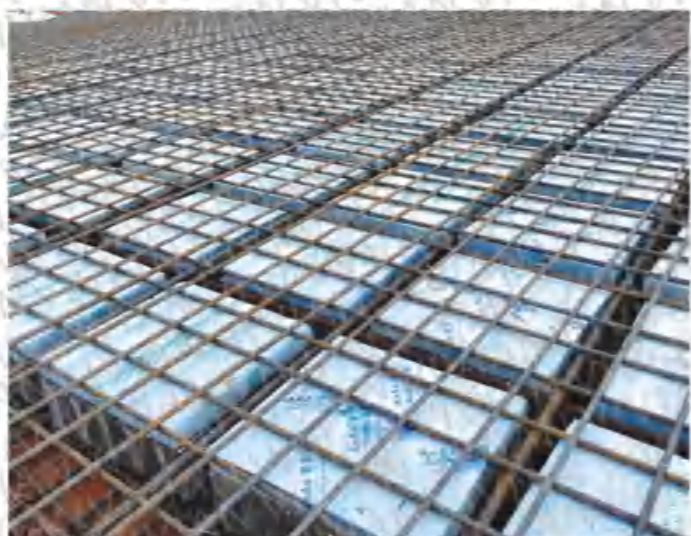

V-180

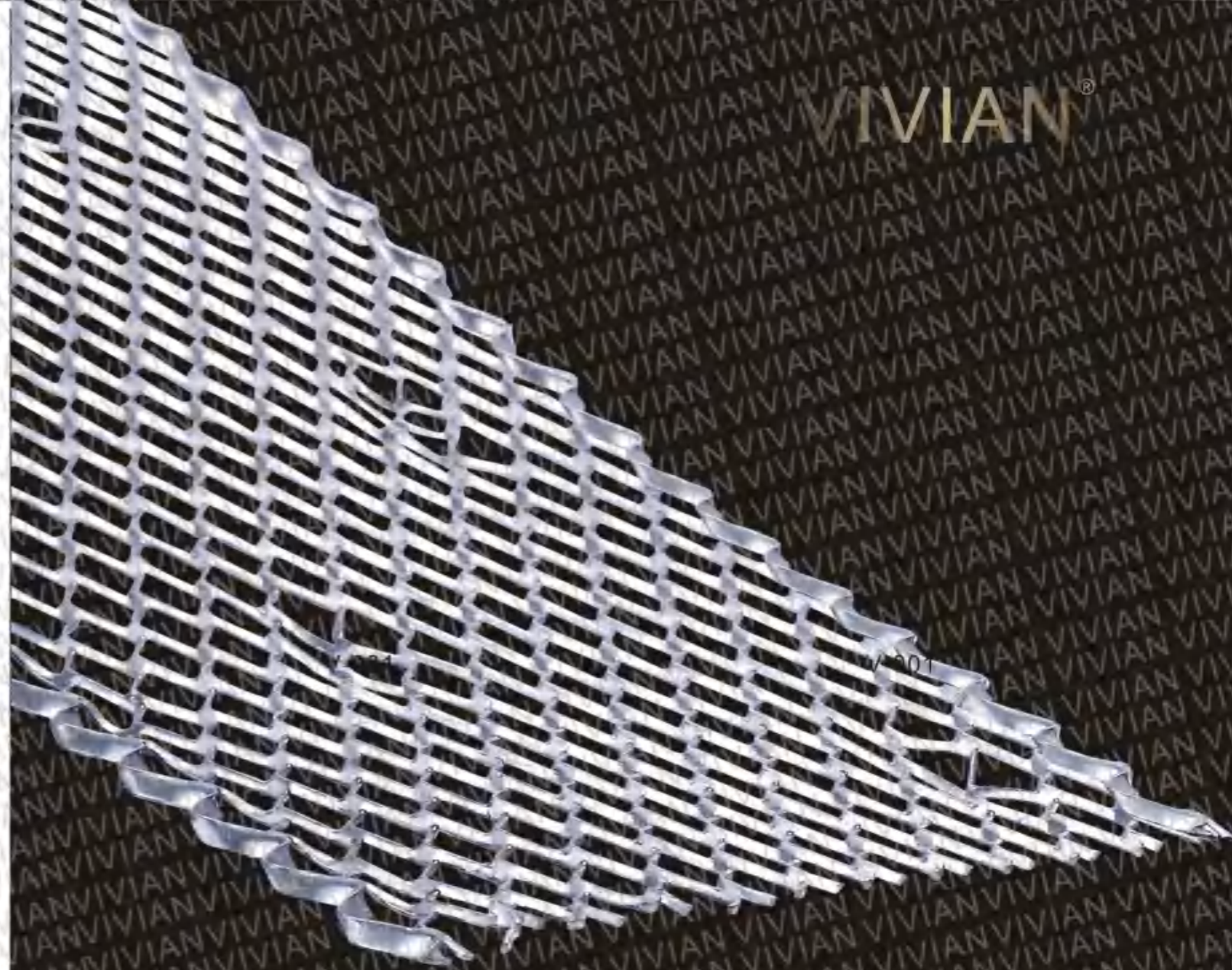

V-201

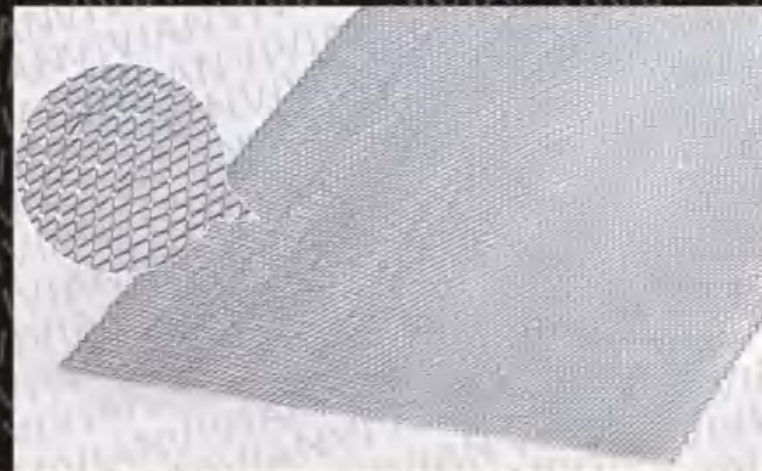

V-181

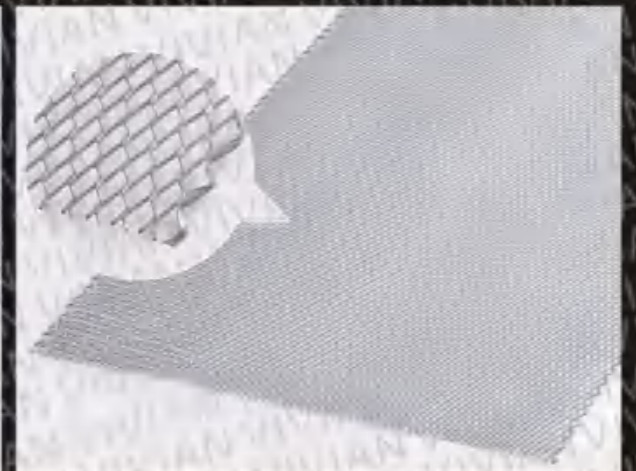

V-182

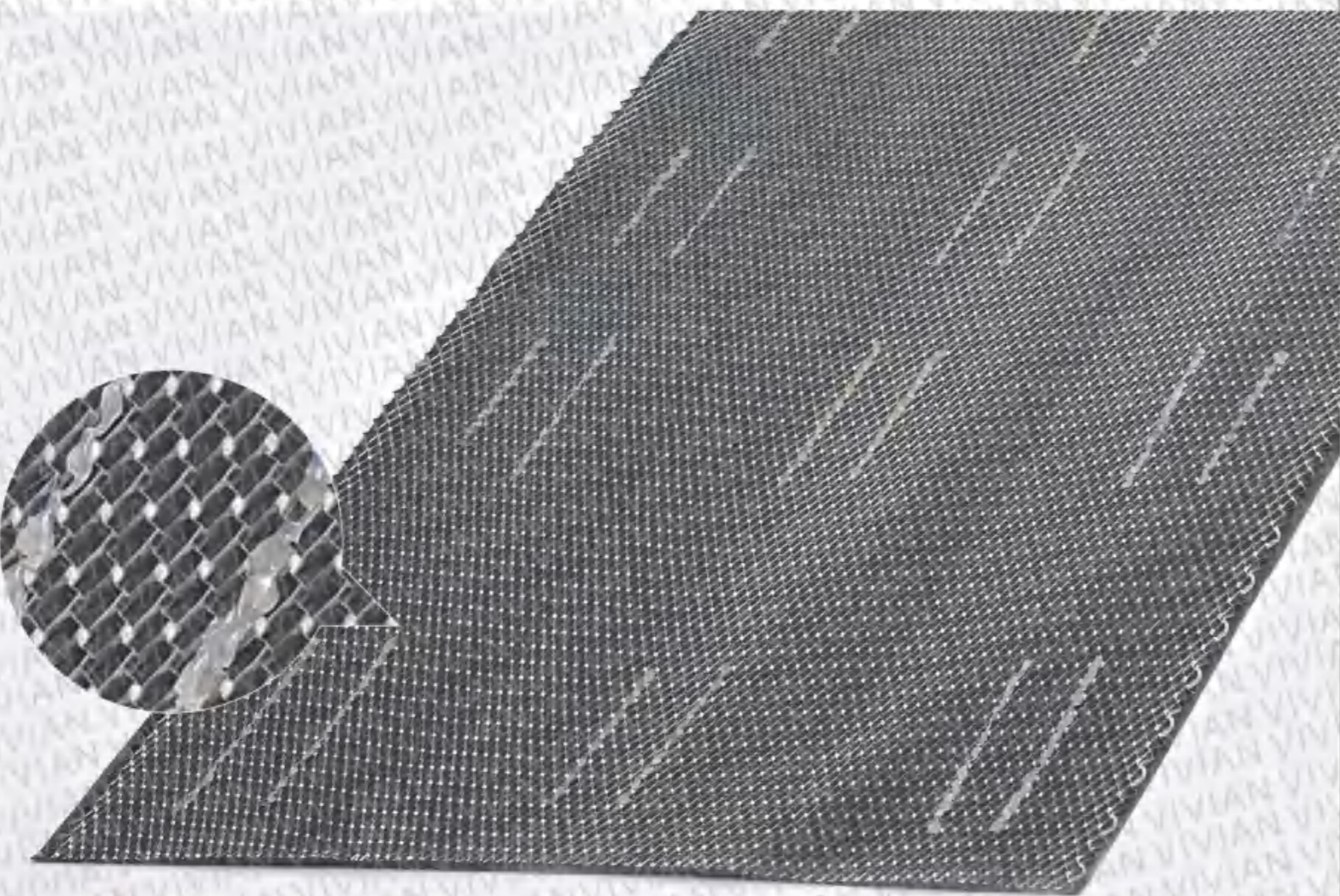

Reference	Size(mm)	Thickness(mm)	Wt(Lbs)	Pcs/Bdl	Pcs/Pallet	Wt(kgs)
V-183	685x2440	0.3	2.9	10	500	1.3
V-184	685x2440	0.35	3.4	10	500	1.54
V-185	685x2440	0.4	3.9	10	500	1.76
V-186	685x2440	0.45	4.4	10	500	1.98
V-187	685x2440	0.5	4.9	10	500	2.2
V-188	685x2440	0.6	5.8	10	500	2.65

Reference	Size(mm)	Thickness(mm)	Wt(Lbs)	Pcs/Bdl	Pcs/Pallet	Wt(kgs)
V-189	685x2135	0.3	2.4	10	500	1.1
V-190	685x2135	0.35	2.8	10	500	1.29
V-191	685x2135	0.4	3.2	10	500	1.47
V-192	685x2135	0.45	3.6	10	500	1.65
V-193	685x2135	0.5	4.1	10	500	1.84
V-194	685x2135	0.6	4.9	10	500	2.2





V-195



V-196



V-197



V-198



V-199



V-200

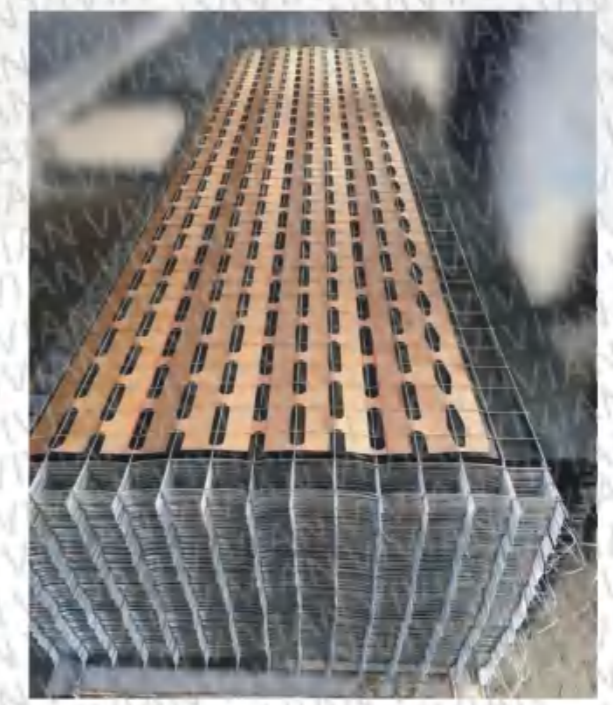
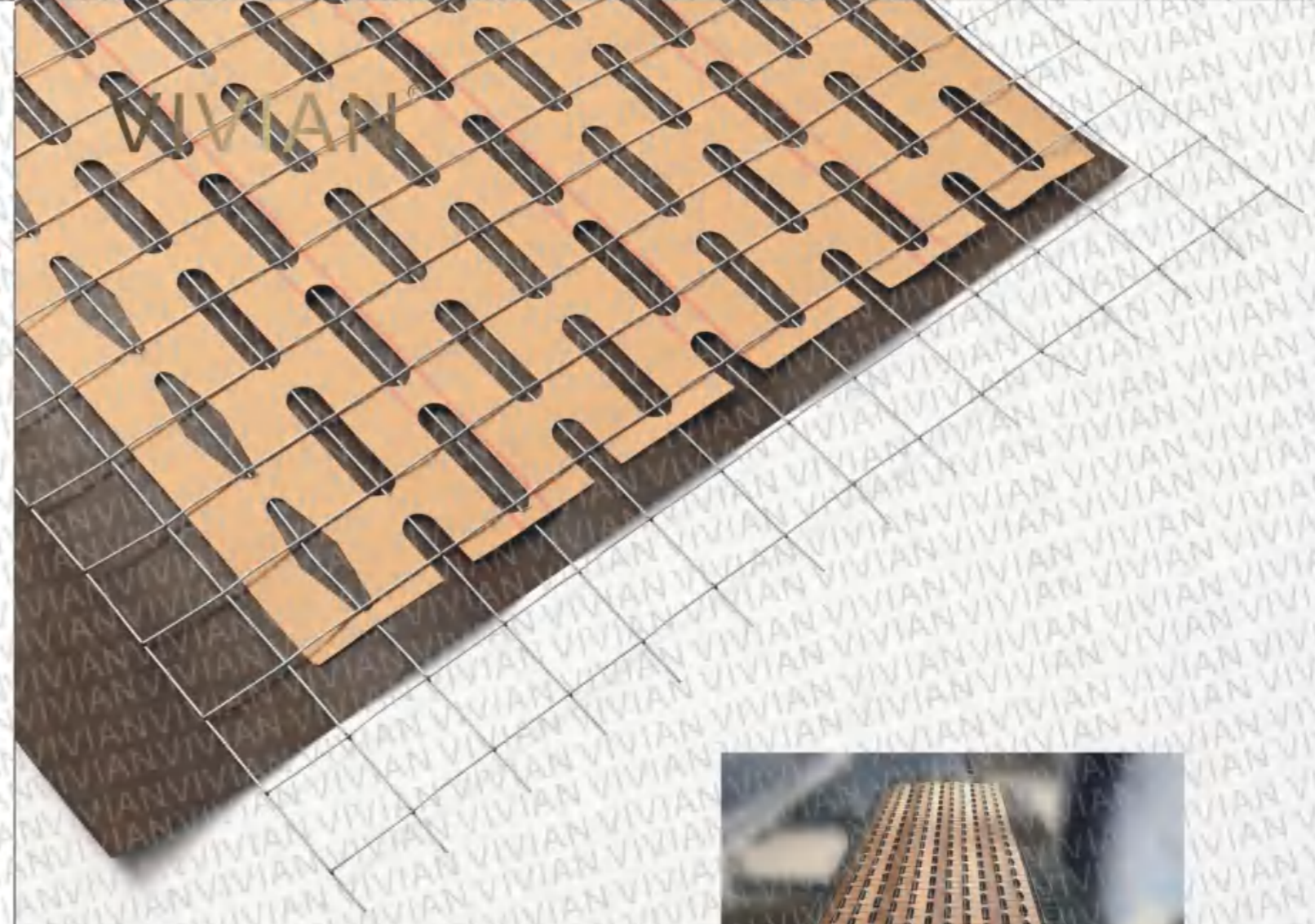

V-201

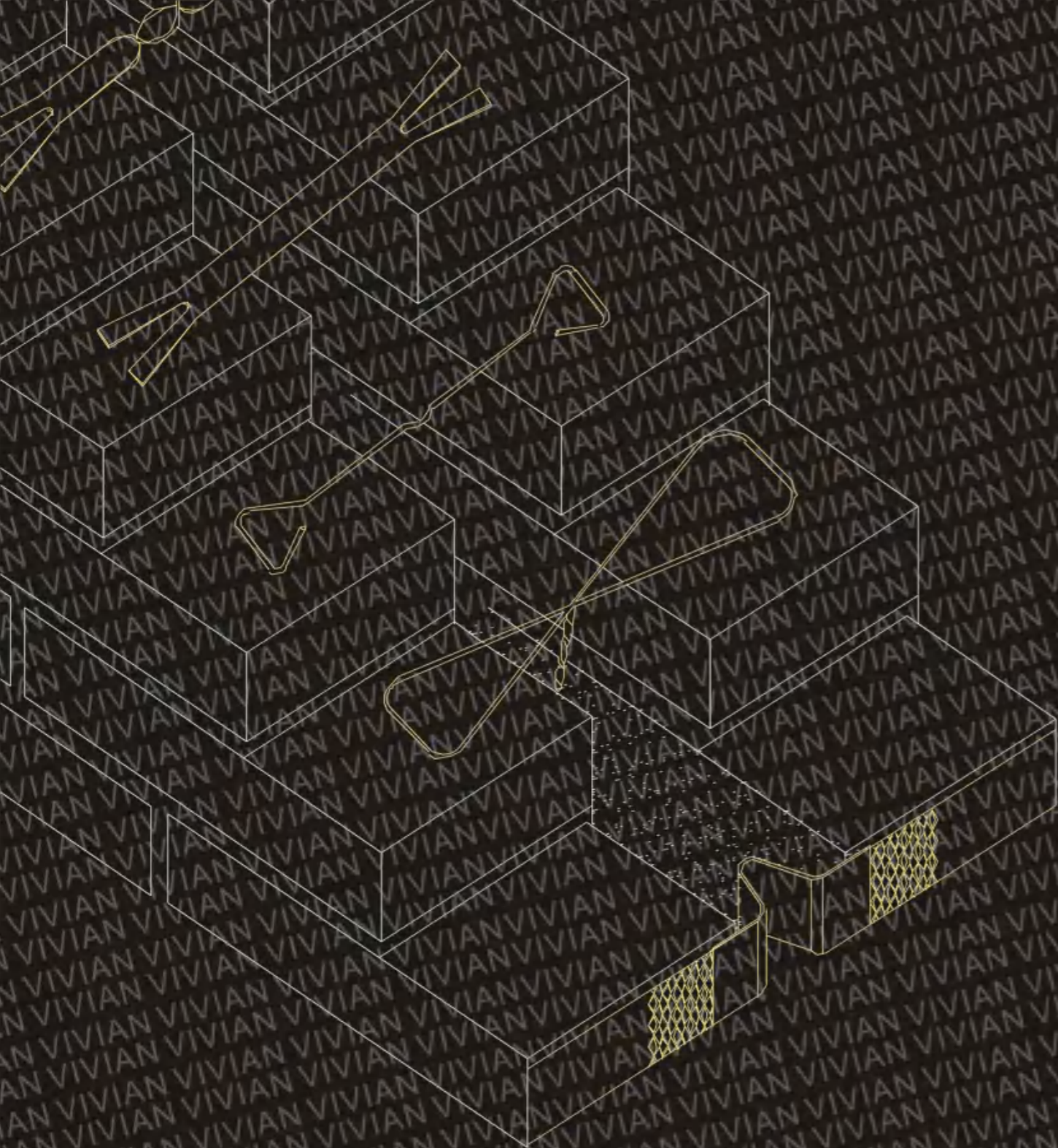

VIVIAN®

VIVIAN®



V-202



V-203



V-204



V-205

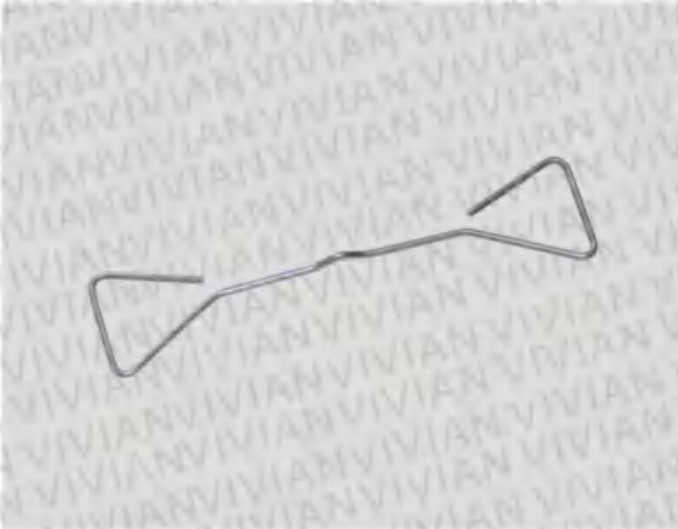

V-206

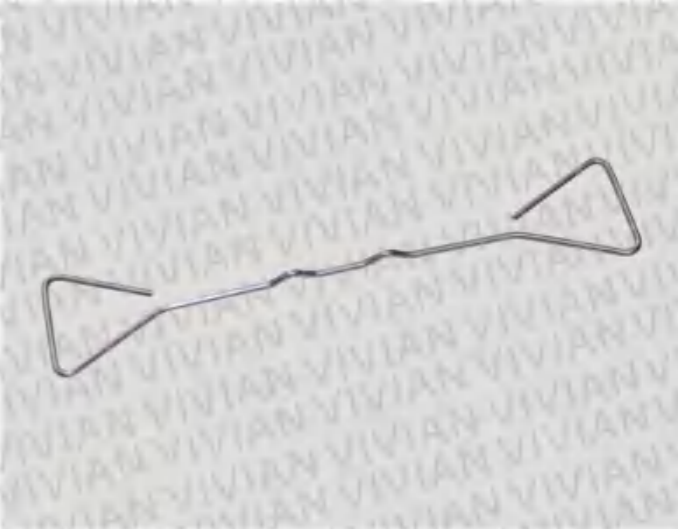

V-207



V-208

V-209



V-210



V-211



V-212



V-213



V-214



V-215



V-216



V-217

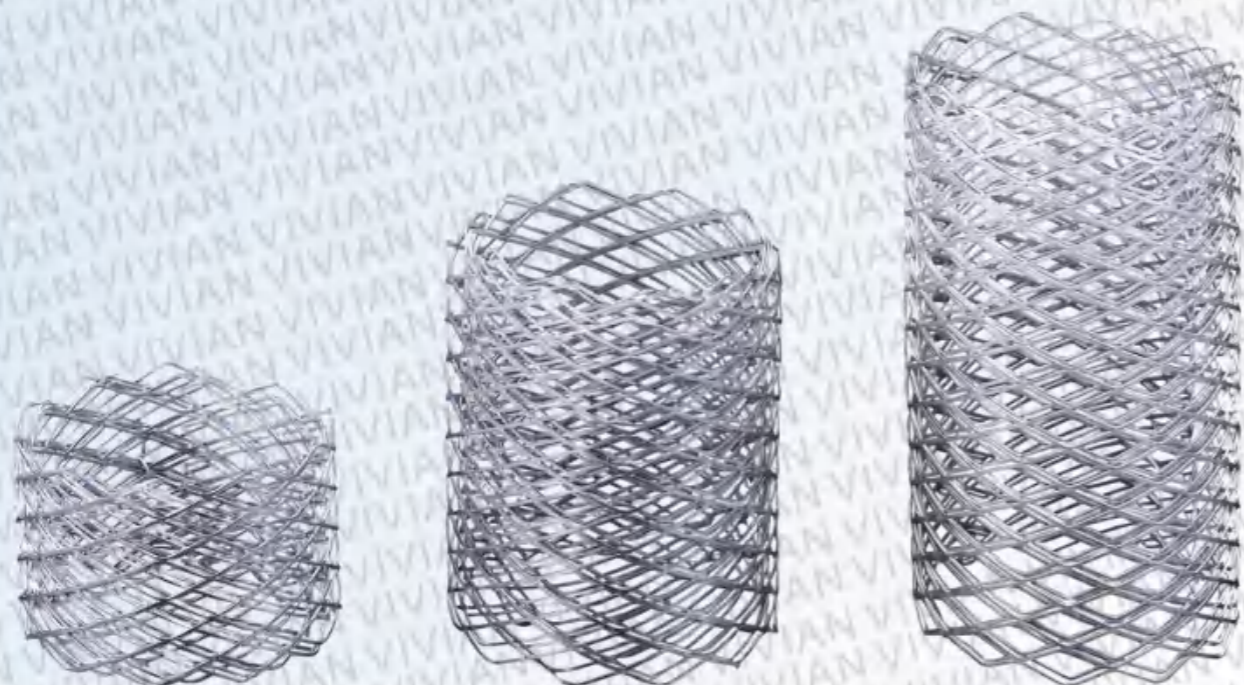

Reference	Coil width(mm)	Coil length(m)	Bore Diameter(mm)	Wall Width(mm)
V-218	50	100	12x25	100
V-219	64	100	12x25	114
V-220	100	100	12x25	150
V-221	114	100	12x25	164
V-222	150	100	12x25	200
V-223	178	100	12x25	228
V-224	200	100	12x25	250
V-225	229	100	12x25	229
V-226	305	100	12x25	355

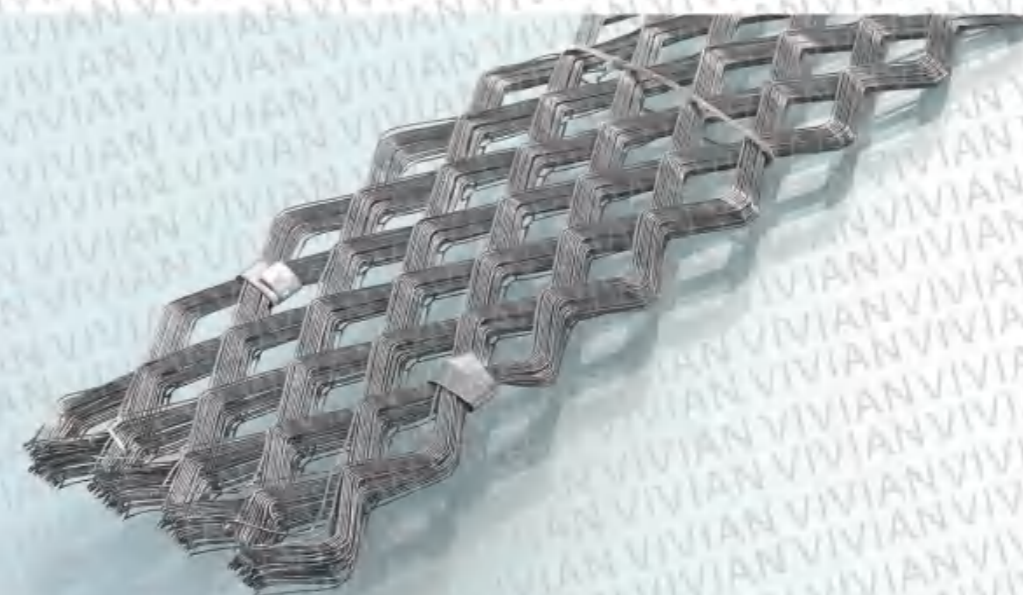
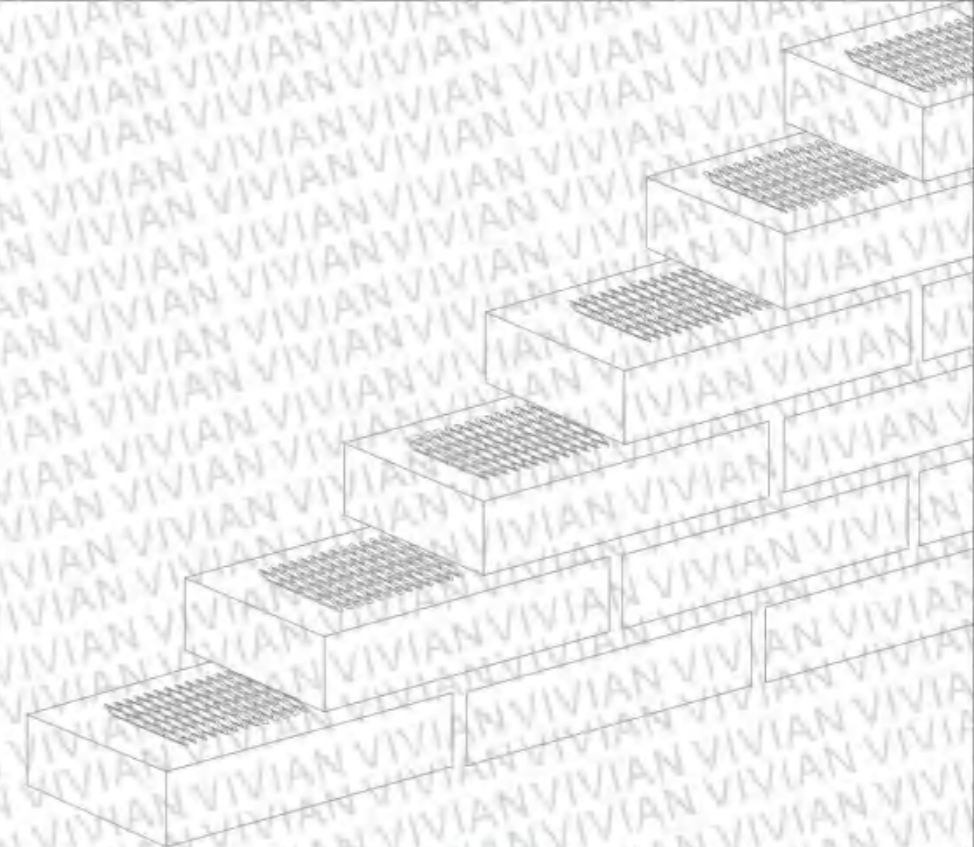

Bundling After Mailed Flat

Reference	Wall width(mm)	Coil width(mm)	Coil length(m)	Bore Diameter	Pcs/ Bdl
V-227	115	65	1.2	18x36mm	200
V-228	130	80	1.2	18x36mm	200
V-229	150	100	1.2	18x36mm	200
V-230	165	115	1.2	18x36mm	200
V-231	250	200	1.2	18x36mm	200



V-232



V-233



V-234



V-235



V-236



V-237



V-238



V-239



V-240



V-241



V-242



V-243



V-244



V-245



V-250



V-251



V-246



V-247

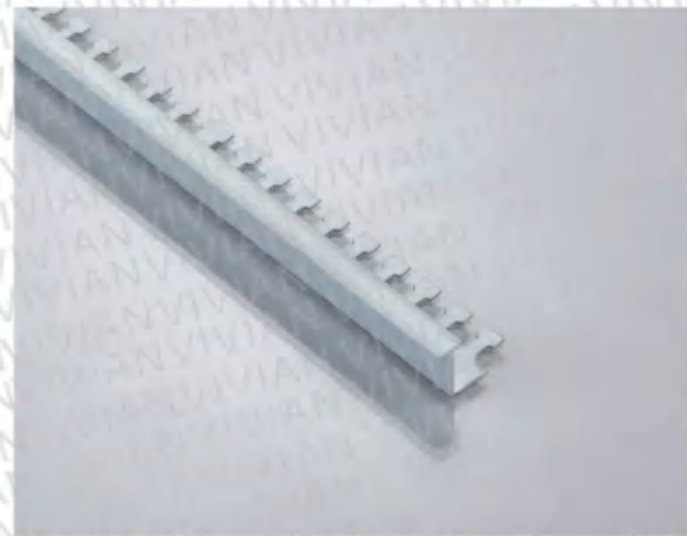

V-252



V-253



V-248



V-249



V-254



V-255



V-256



V-257

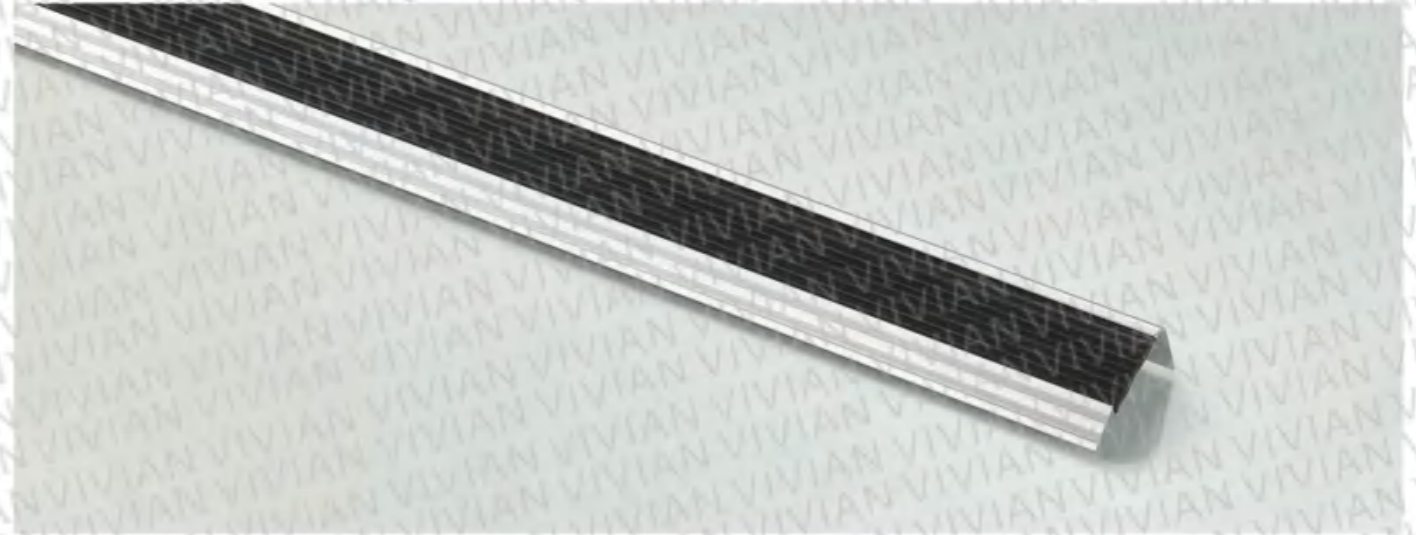

V-262



V-258



V-259



V-263

V-264



V-260



V-261



V-265



V-266



V-267



V-268



V-269



V-270



V-271



V-272



V-273



V-274



V-275



V-276



V-277



V-278



V-279



V-280



V-281



V-282



V-283

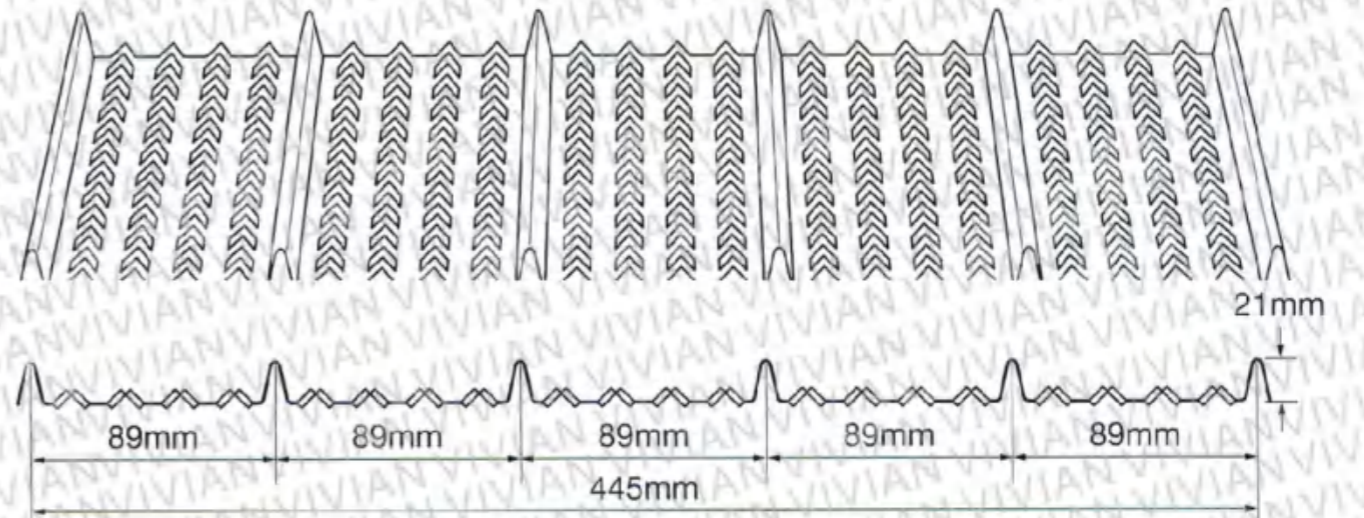

V-284



100mm wide solid walls

Lintel dimension (mm)	Lintel type/code	Steel thickness (mm)	Weight per metre (kg)	Safe Working Load Uniformly Distributed (tonnes) lengths available (mm) in increments of 100 (mm)								
				W	H	900-1200	1300-1500	1600-1800	1900-2100	2200-2400	2500-2700	2800-3000
103	50	V-285	2.0	3.0	0.55	0.42	0.31	-	-	-	-	-
			2.5	3.7	0.80	0.58	0.33	0.24	0.18	-	-	
			3.1	4.7	1.12	0.66	0.44	0.31	0.23	0.16	0.13	
75	V-286	3.1	5.9	1.63	1.25	1.00	0.86	0.64	0.47	0.38		
		2.0	3.7	0.48	0.37	0.27	-	-	-	-		
153	50	V-287	2.5	4.7	0.76	0.58	0.41	0.27	0.19	-	-	
			3.1	5.9	1.22	0.79	0.52	0.37	0.28	0.19	0.14	
			75	V-288	3.1	7.1	1.63	1.25	1.00	0.86	0.64	0.47
203	50	V-289	2.0	4.4	0.62	0.48	0.35	-	-	-	-	
			2.5	5.6	0.77	0.59	0.41	0.29	0.21	-	-	
			3.1	7.1	1.05	0.80	0.53	0.38	0.28	0.19	0.14	
75	V-290	3.1	8.5	1.63	1.25	1.00	0.86	0.64	0.47	0.37		
		2.0	5.4	0.62	0.48	0.35	-	-	-	-		
		2.5	6.7	0.77	0.59	0.41	0.29	0.21	-	-		
253	50	V-291	3.1	8.6	1.05	0.80	0.53	0.38	0.28	0.19	0.14	



75-100mm wide Internal Walls

Wall width (mm)	Lintel type code	Lintel dimension (mm)		Steel thickness (mm)	Weight (kg per metre)	safe working load (tonnes)	Lengths available (metres)
		W	H				
75	V-292	65	25	1.2	1.2	0.7	1.05&1.20
100	V-293	98	25	1.2	1.8	0.7	1.05&1.20





V-294



V-295



V-296



V-297



V-298

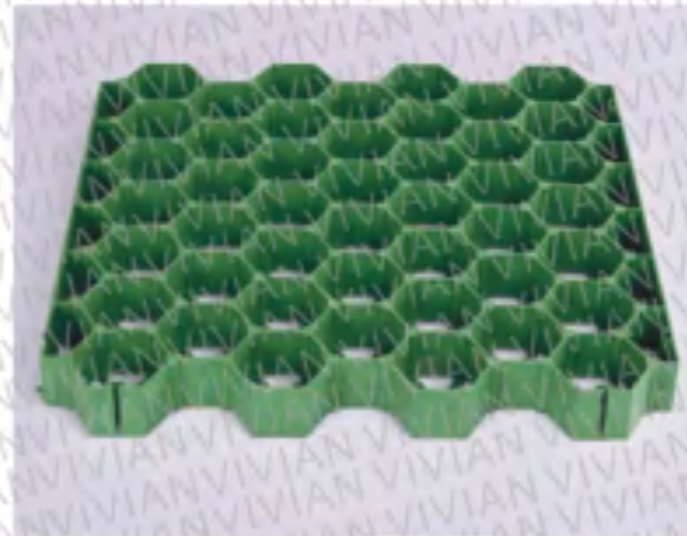

V-299



V-300

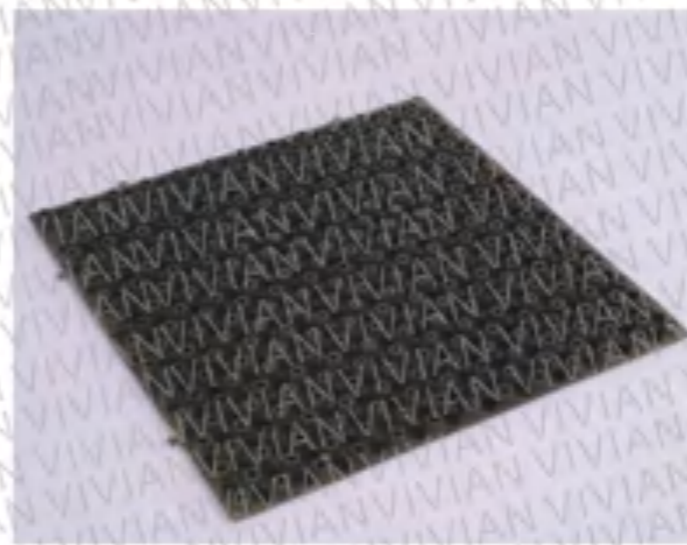

V-301



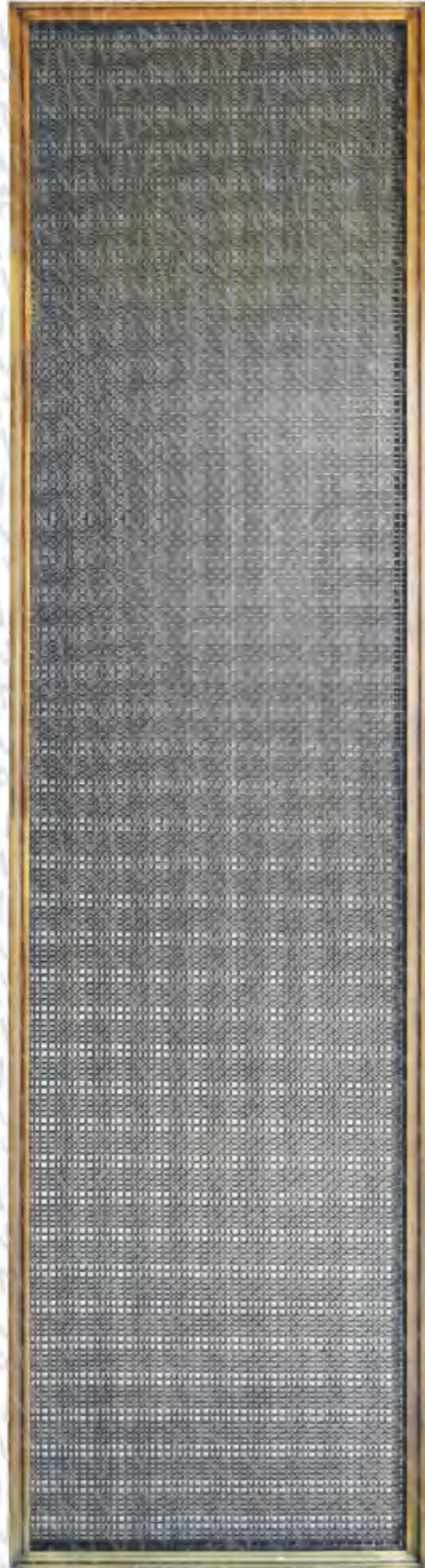

V-302

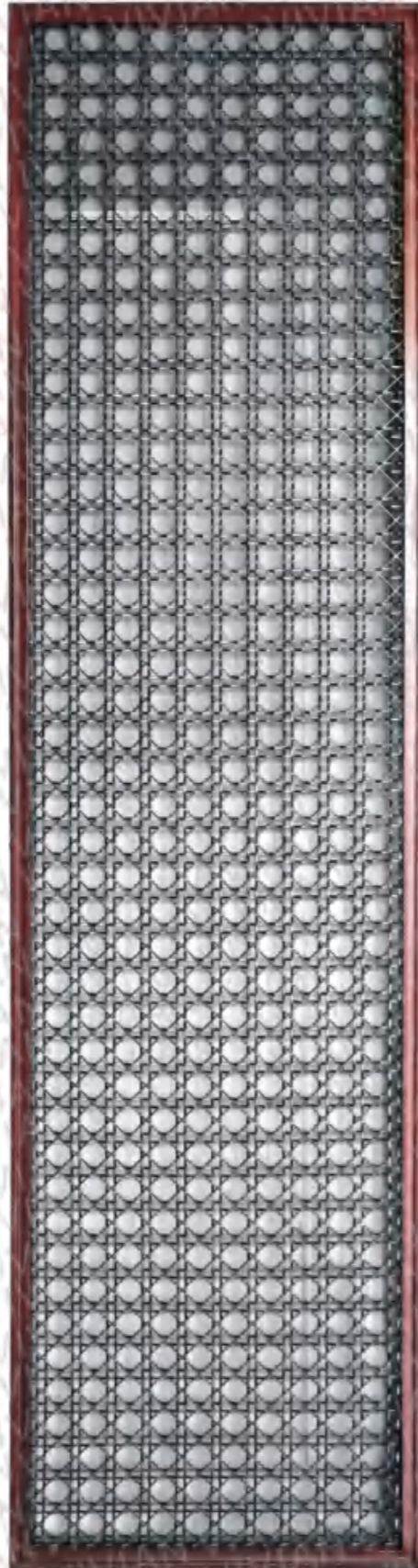

V-303



V-304



V-305



V-306



V-307

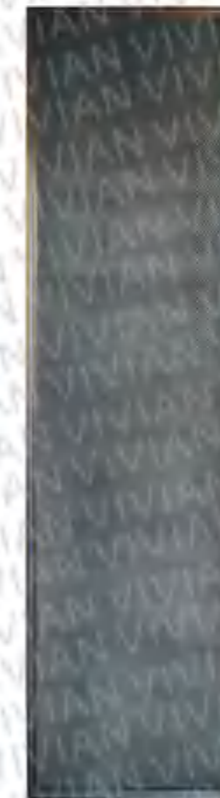

V-308



V-309



V-310



V-311



V-312



V-313



V-314



V-315



V-316



V-317



V-318



V-319



V-320

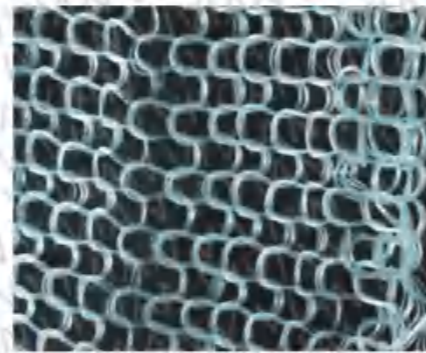

V-321



V-322

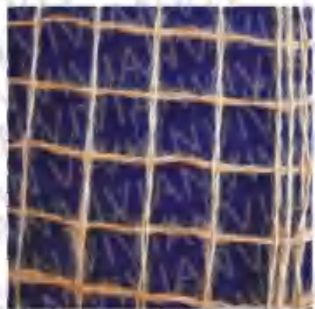

V-323

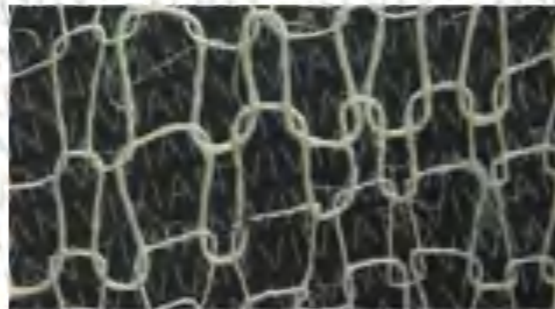

V-324

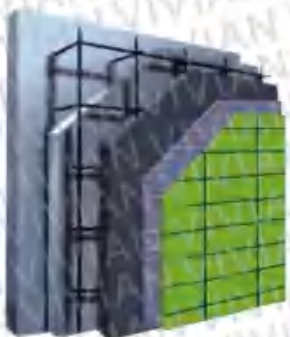

V-325



V-326

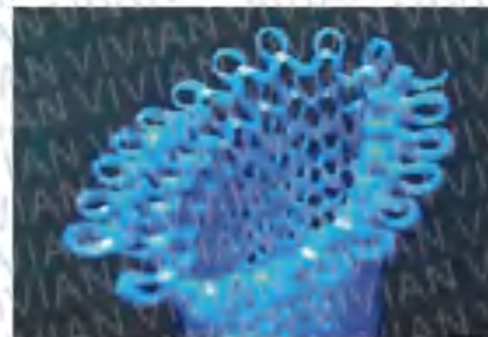

V-327

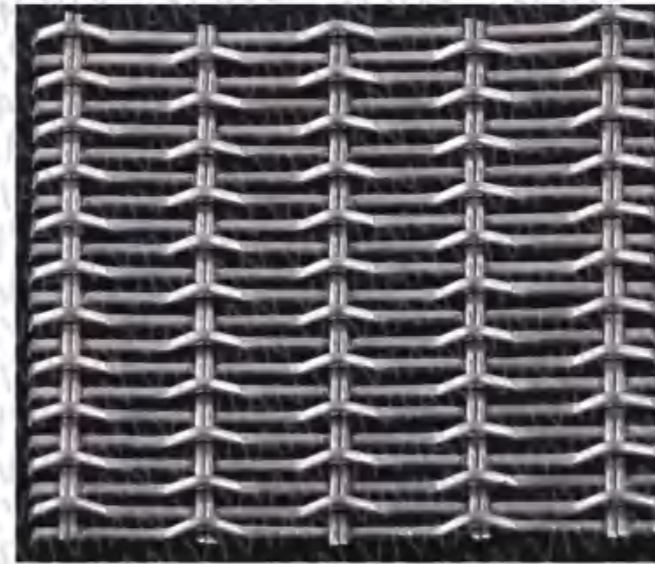

V-328

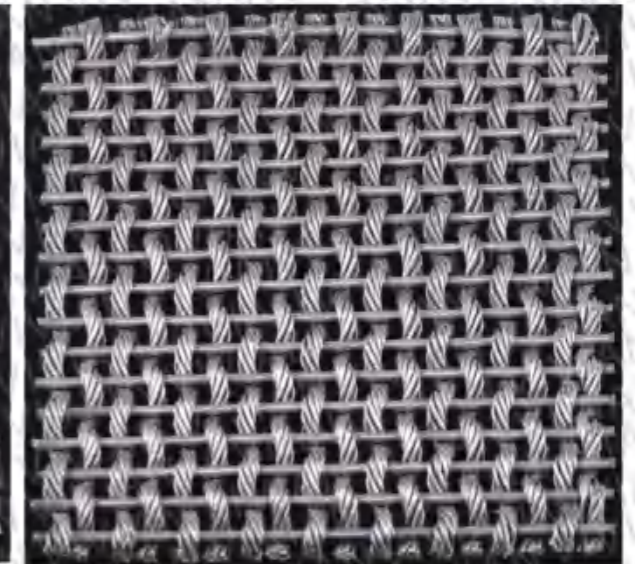

V-329



V-330

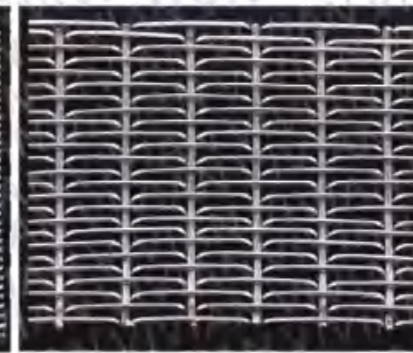

V-331

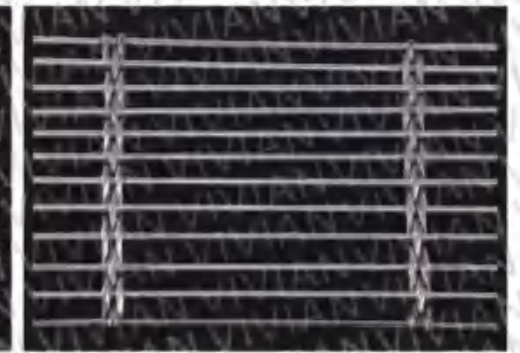

V-332

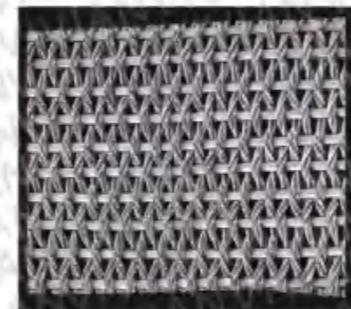

V-333

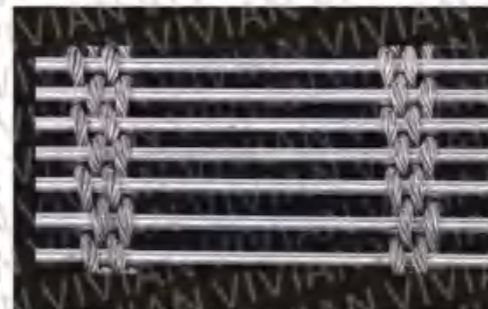

V-334

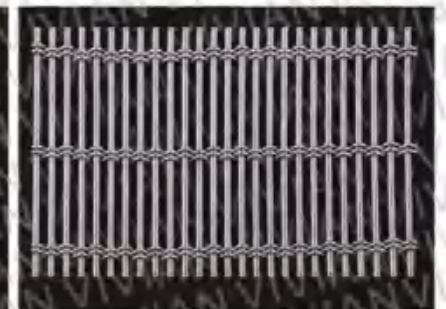

V-335



V-336

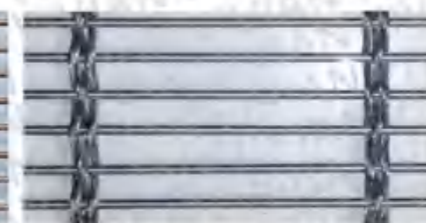

V-337



V-338



V-339



V-340

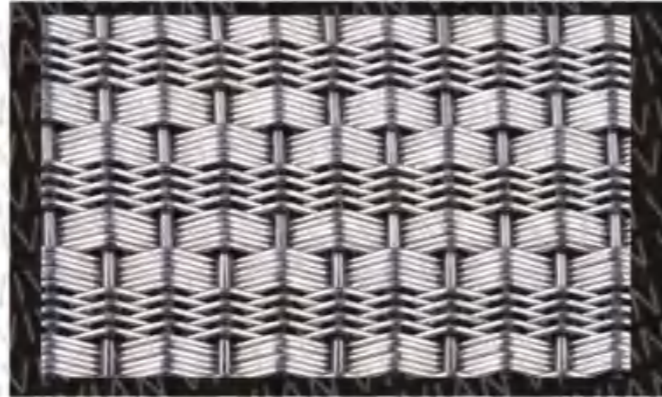

V-341



V-342



V-343



V-344



V-302



V-302



V-302



V-345



V-346



V-347



V-348

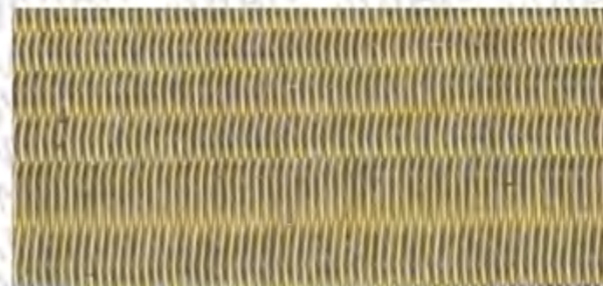

V-349



V-350



V-351



V-352

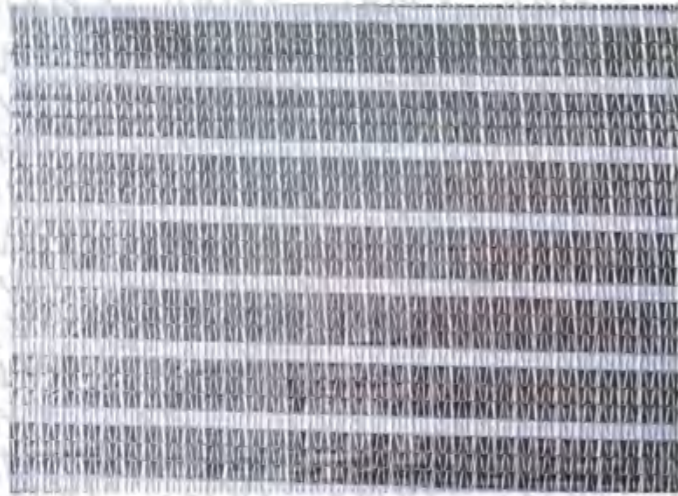

V-353



V-354



V-355

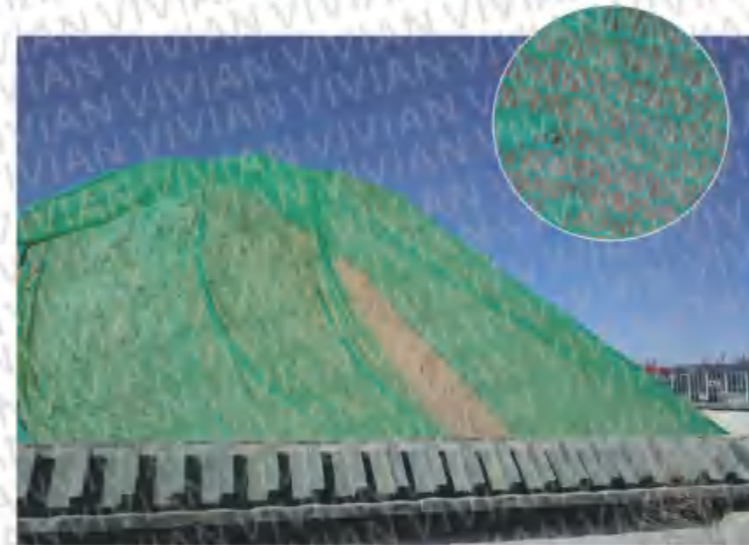

V-356



V-357

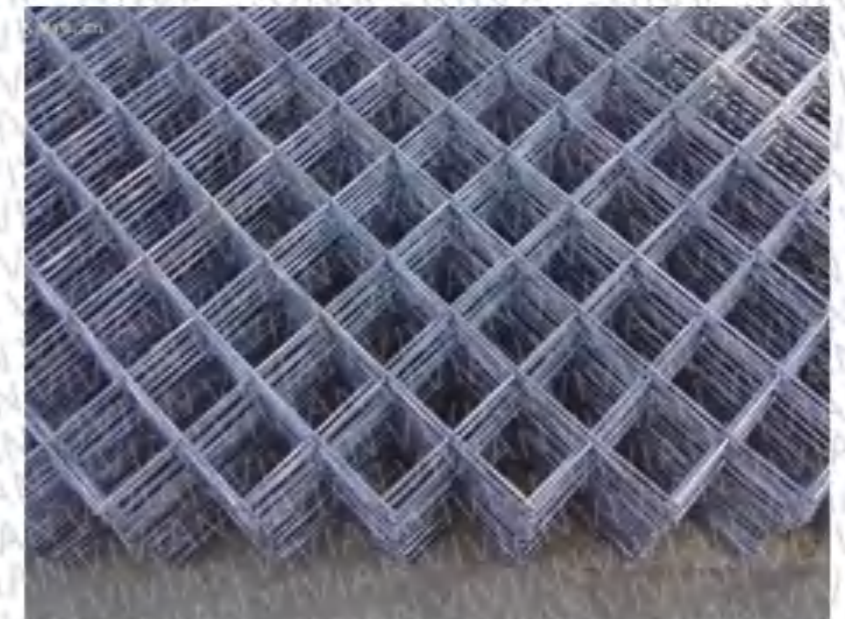

V-358



V-359

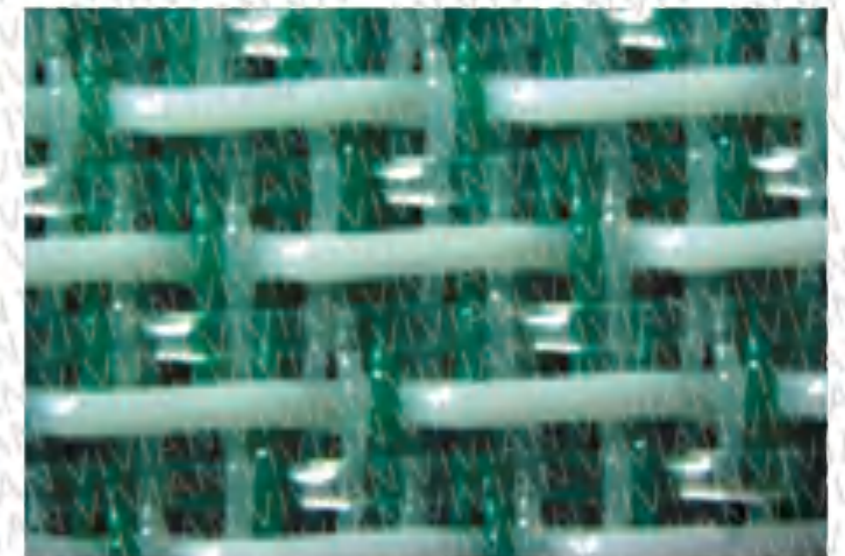

V-361



V-360



V-362

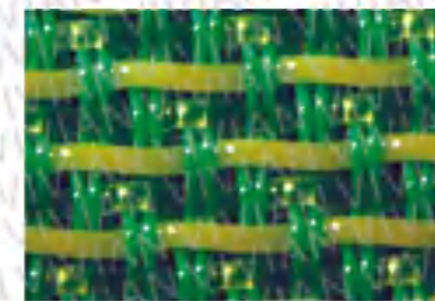

V-363



V-364



V-365



V-366



V-367

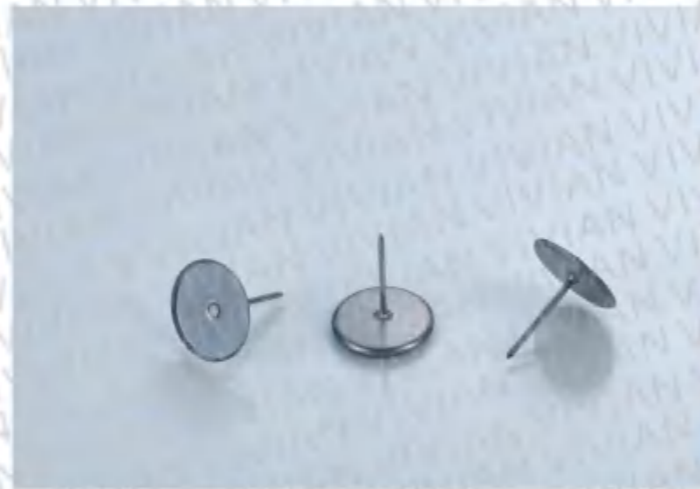

V-368

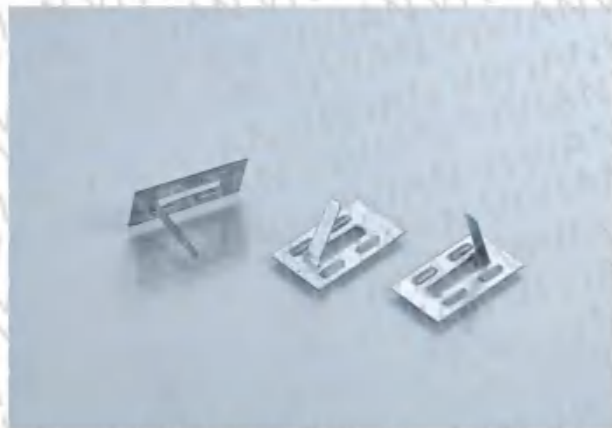

V-369



V-370



V-371



V-372



V-373



V-374



V-375



V-376

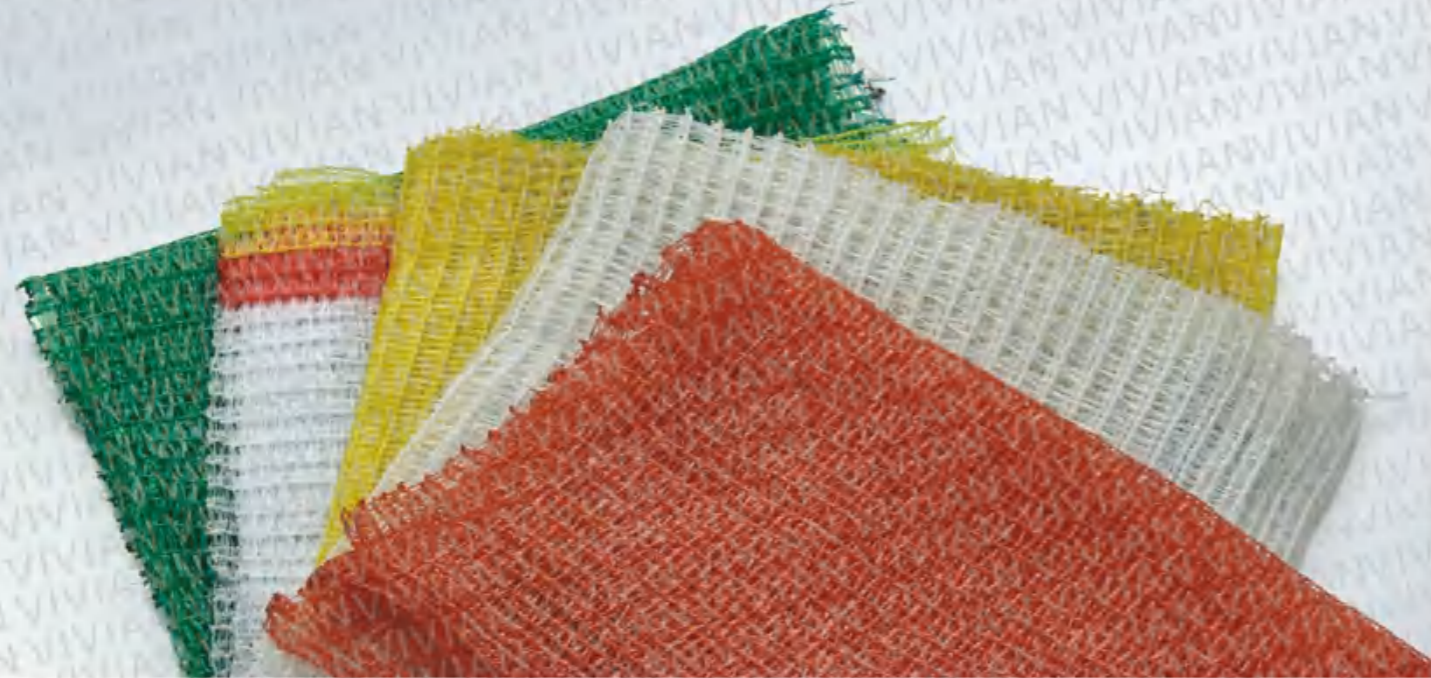

V-377



V-378



V-379



V-380



V-381



V-382

VIVIAN®



V-383

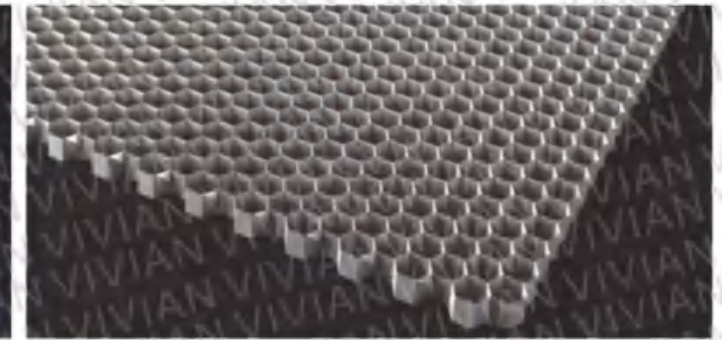

V-384



V-385



V-386



V-387

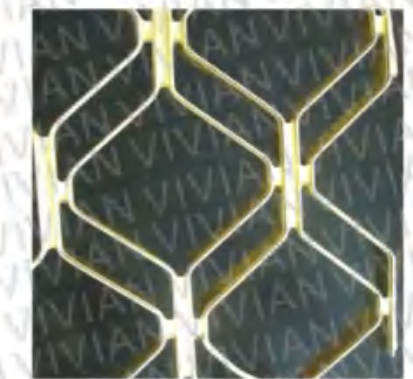

V-388

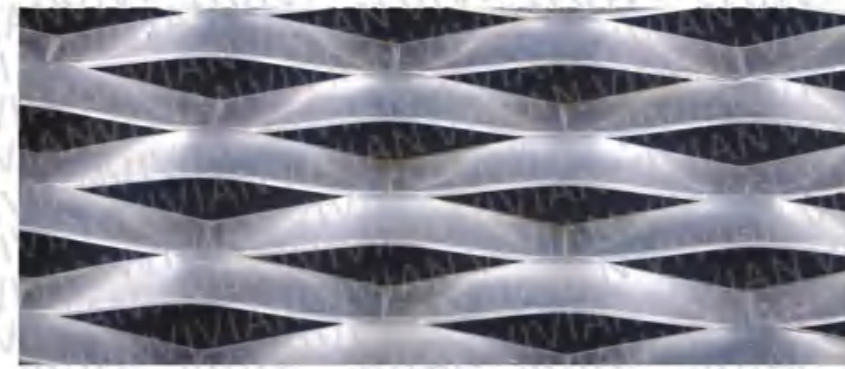

V-389



V-390



V-391



V-392



V-393



V-394



V-395



V-396

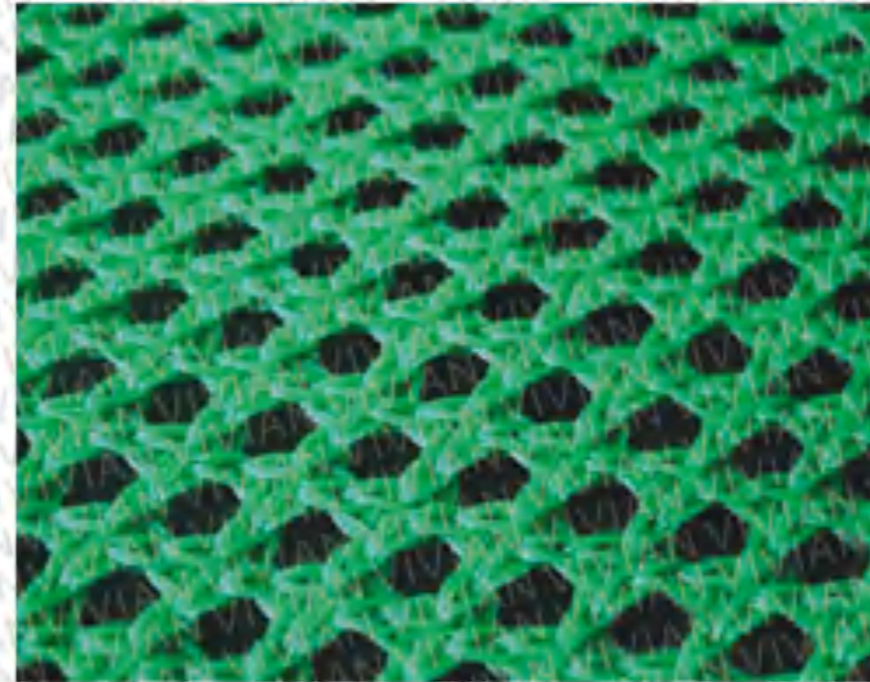

V-397

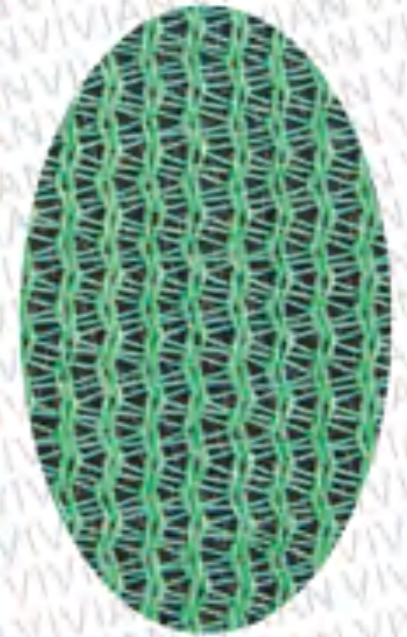

V-398



V-399



V-400

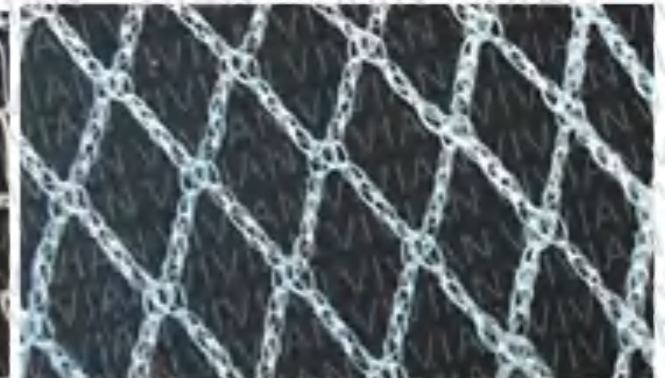

V-401



V-402



V-403

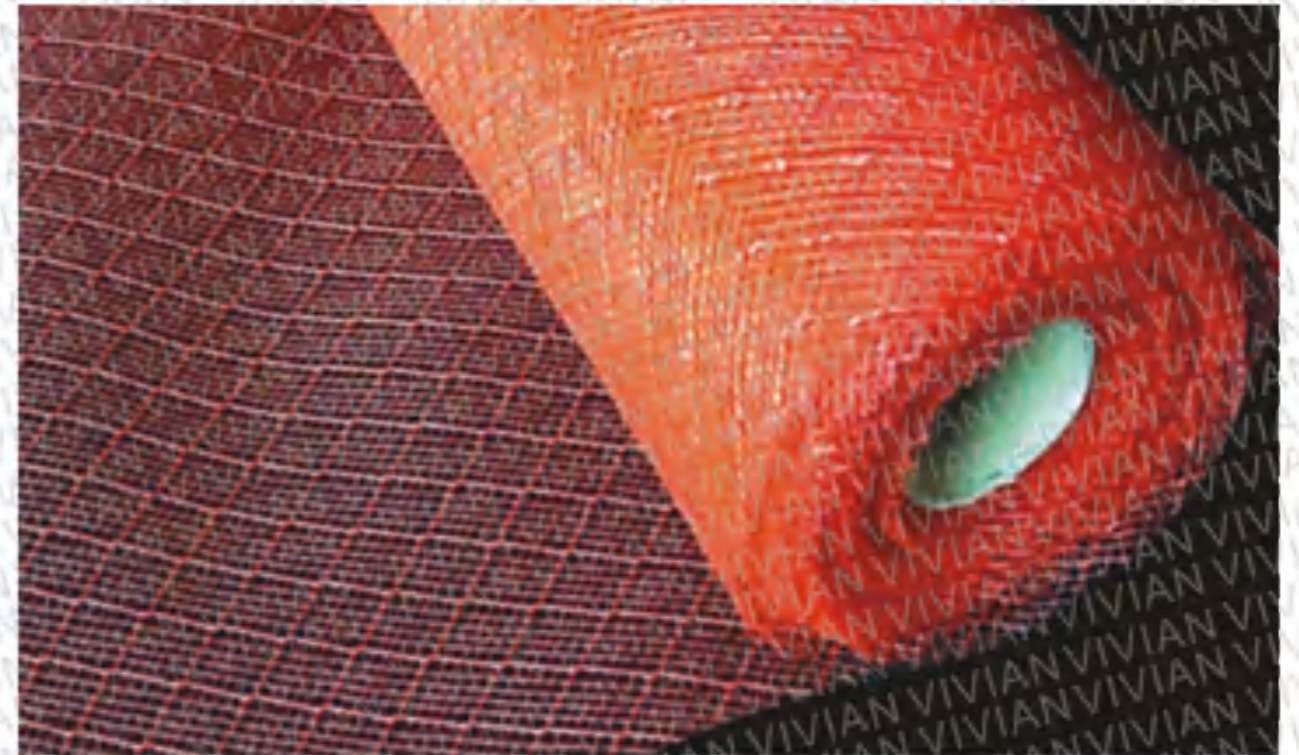

V-409



V-404



V-405



V-410



V-411

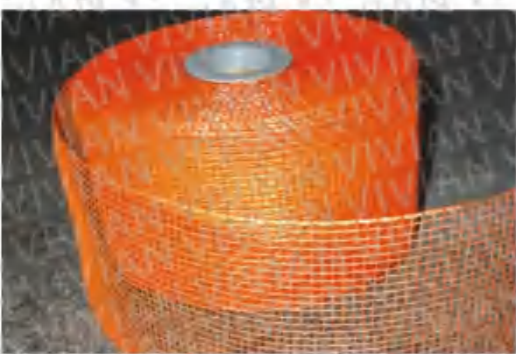

V-406

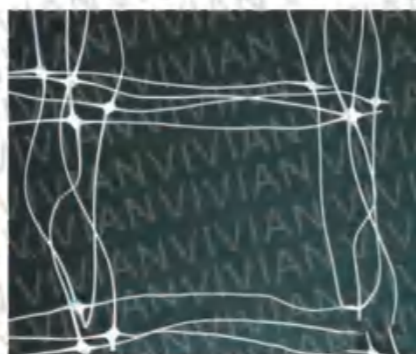

V-407



V-408



V-412

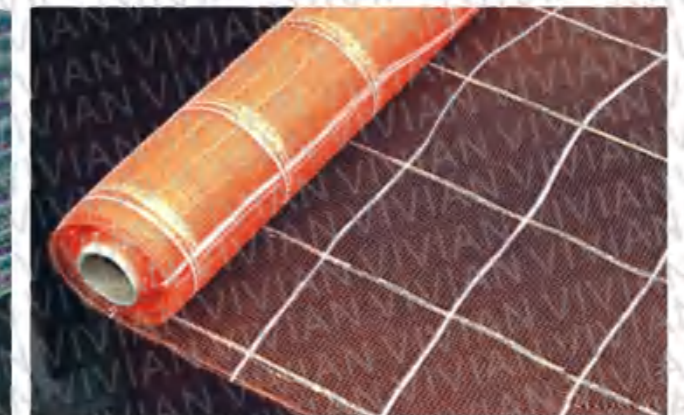

V-413

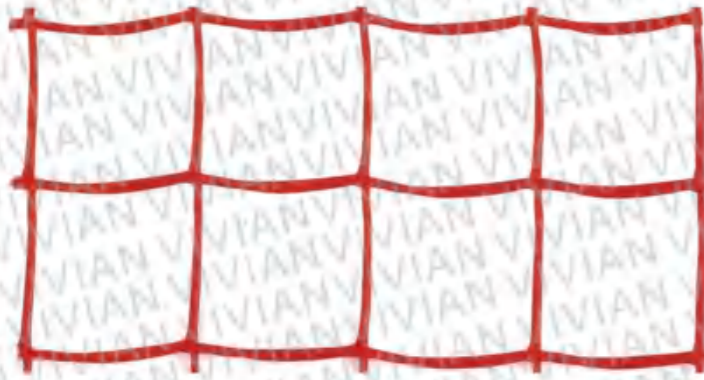

V-414



V-416

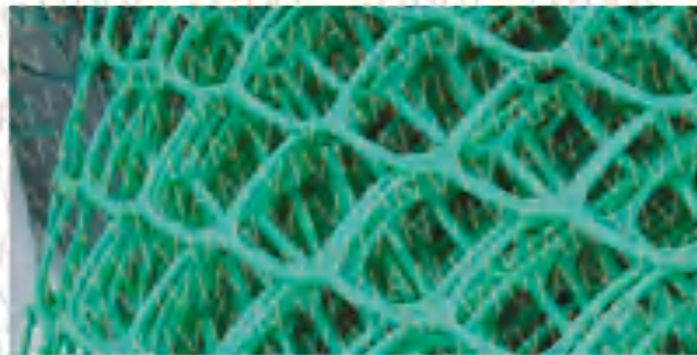

V-415



V-418



V-417

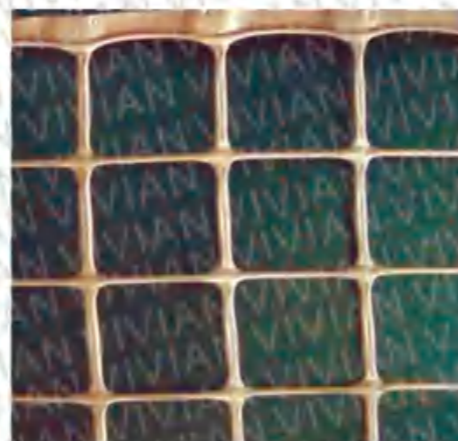

V-419

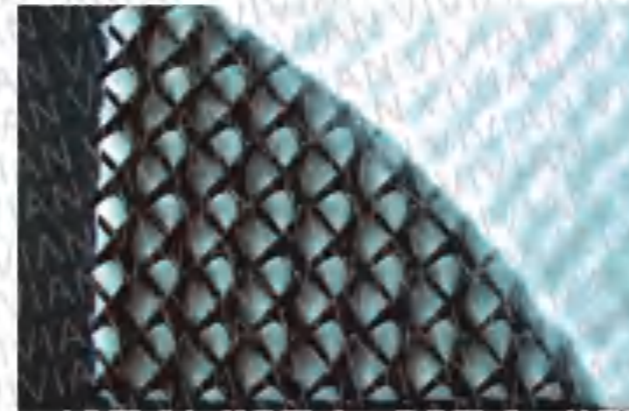

V-420



V-421

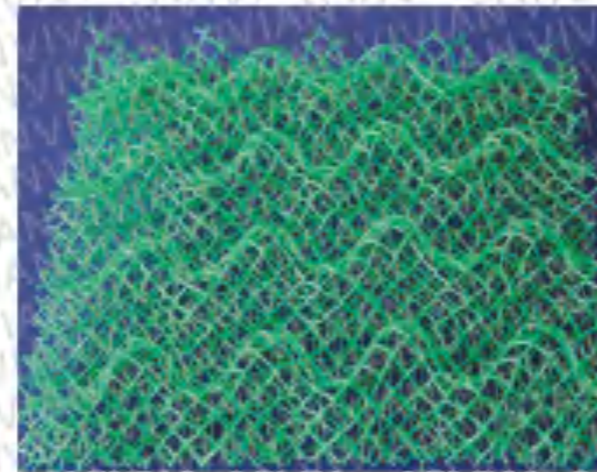

V-422



V-423



V-424

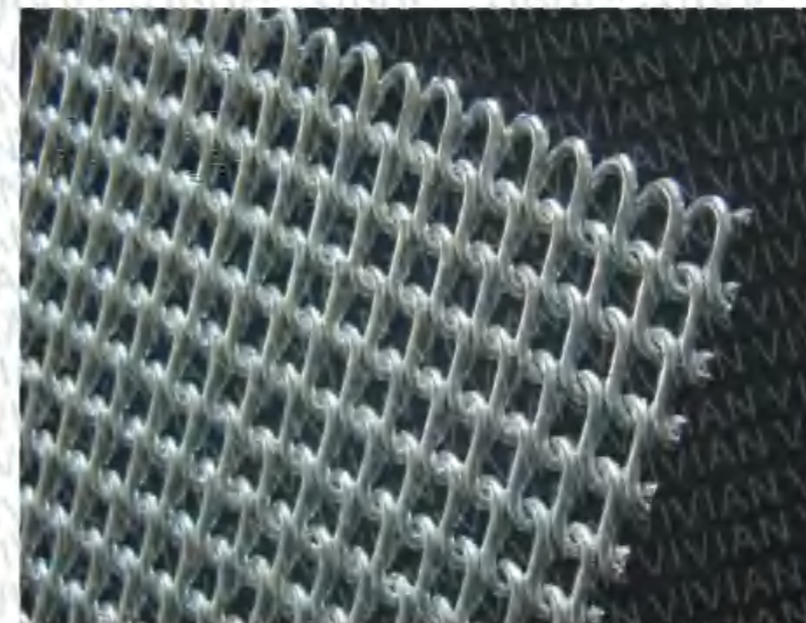

V-426

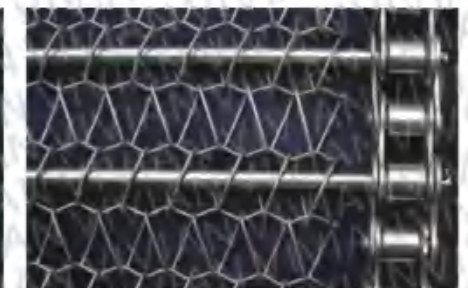

V-425



V-427



V-428



V-429

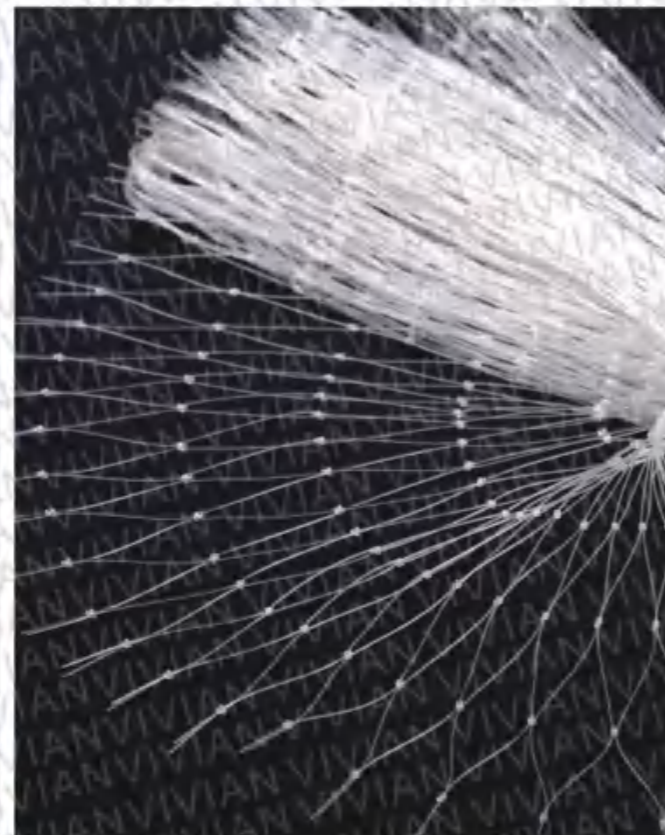

V-430

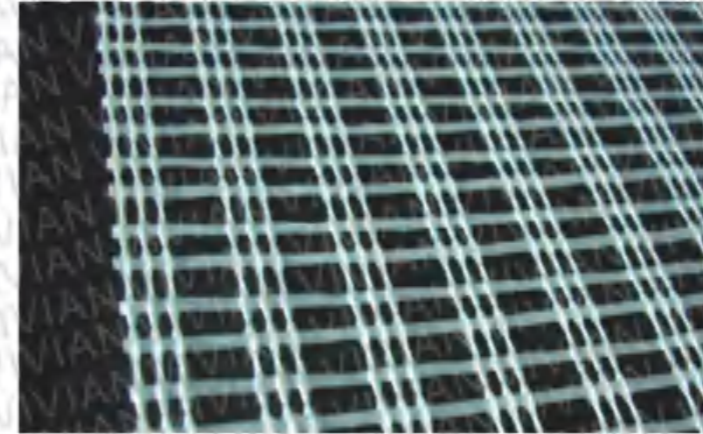

V-431

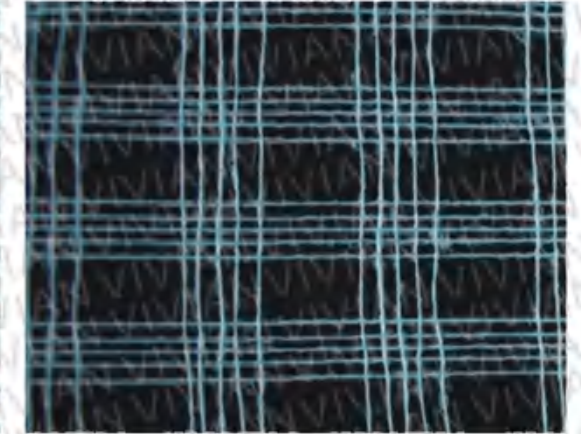

V-432

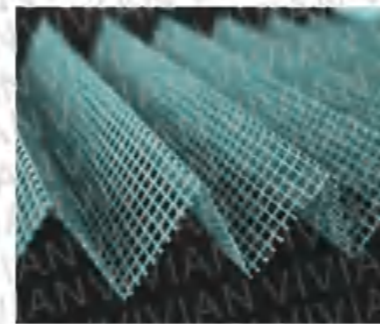

V-433

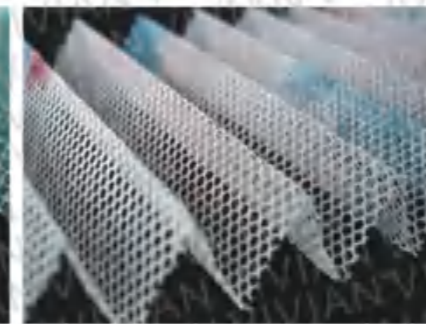

V-434



V-435



V-436



V-437

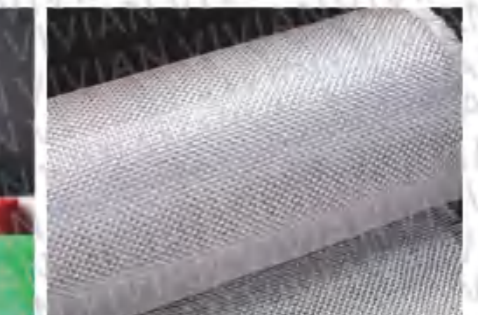

V-438



V-439



V-440



V-441

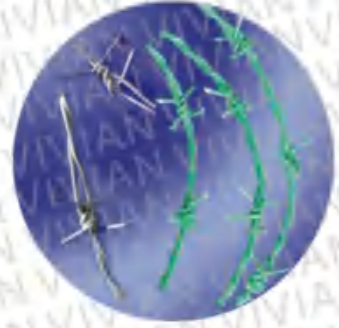

V-442



V-443



V-444



V-445



V-446



V-447



V-448



V-449



V-450

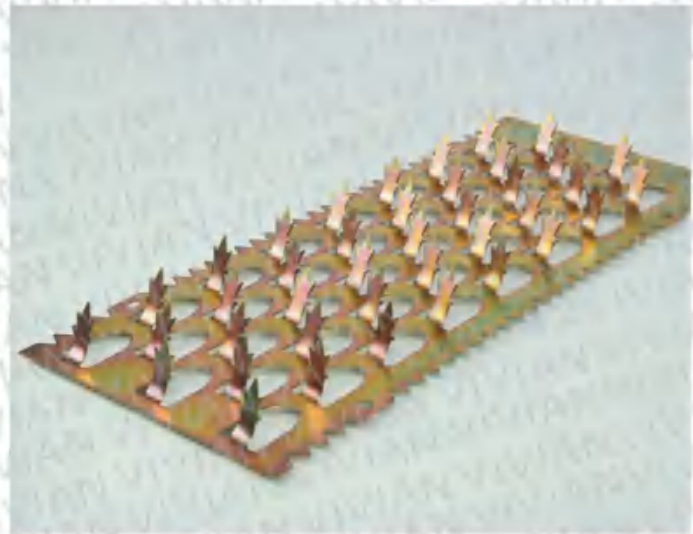

V-451



V-452



V-453



V-454



V-455



V-456

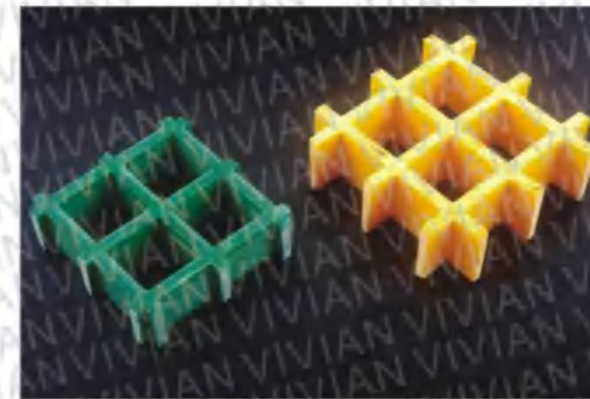

V-457



V-458



V-459

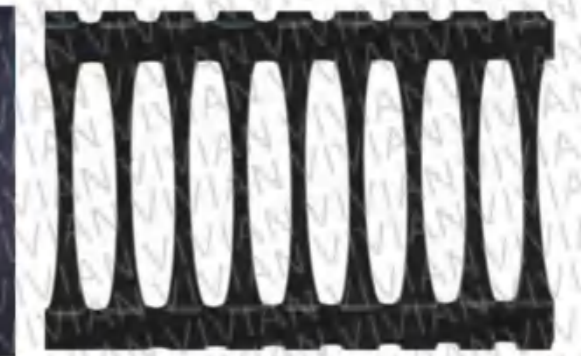

V-460



V-461



V-462



V-463



V-466



V-464

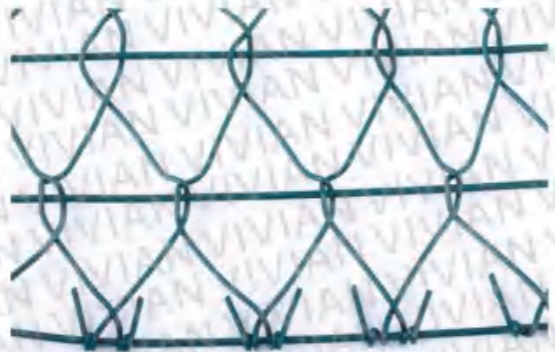

V-465



V-467



V-468



V-469



V-470



V-471



V-472

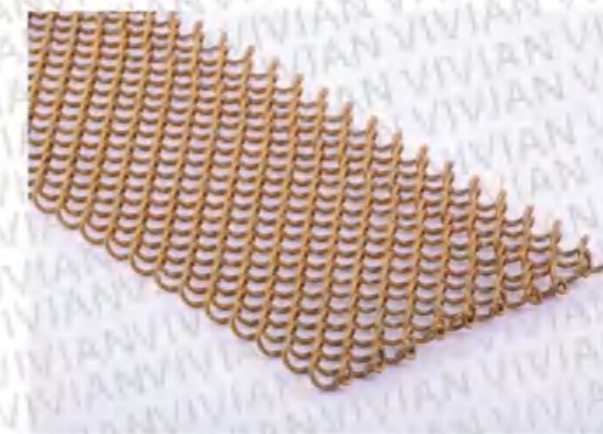

V-473

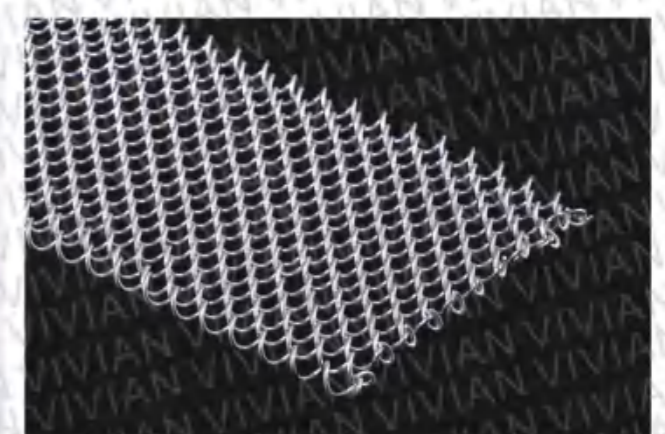

V-474



V-475



V-476

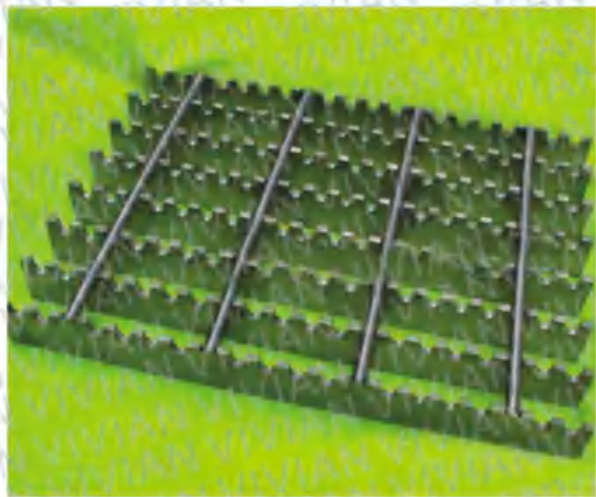

V-477



V-478

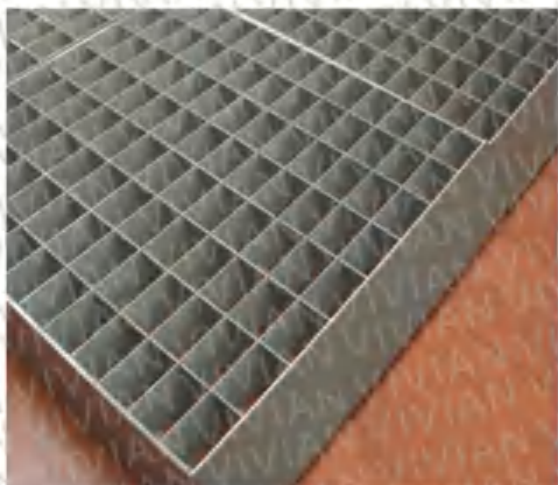

V-479

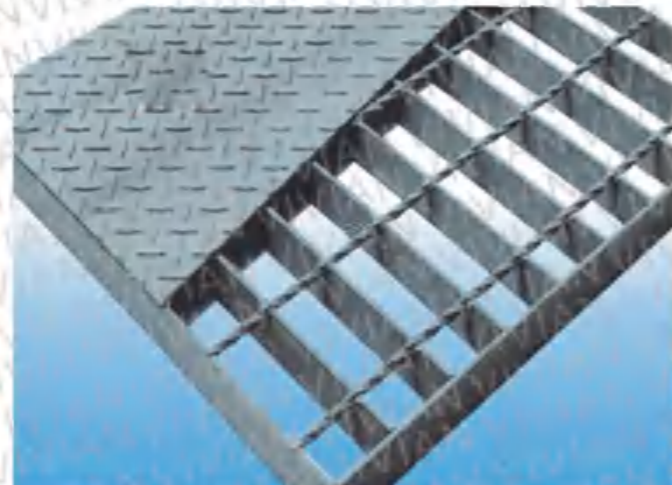

V-480

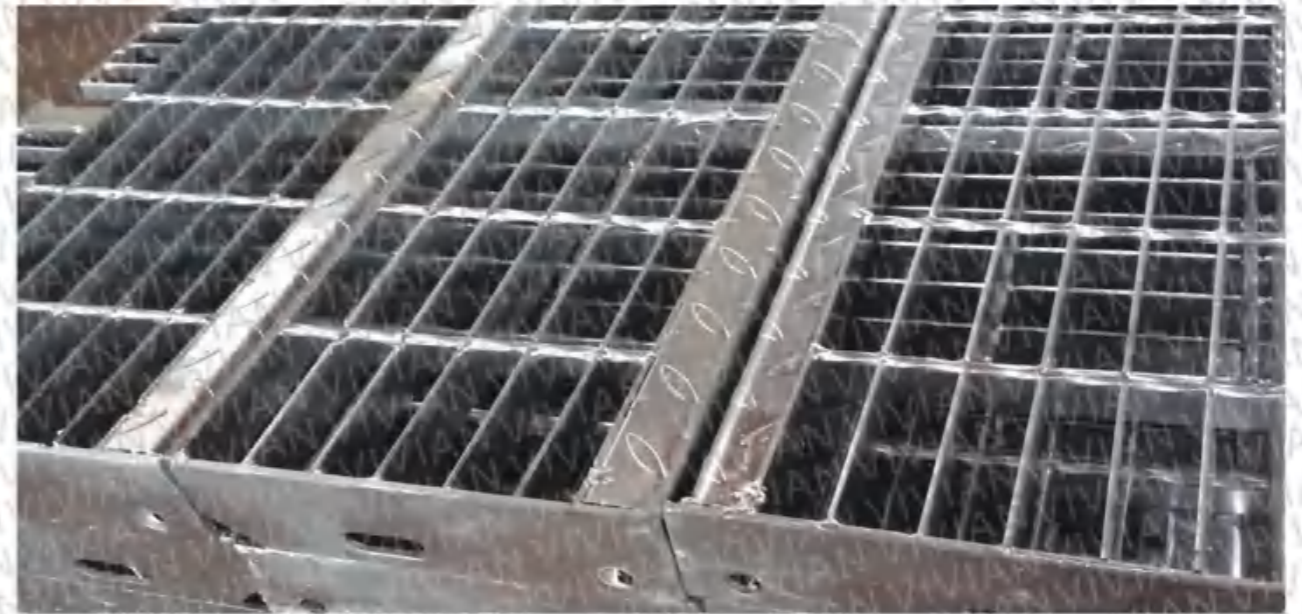

V-481

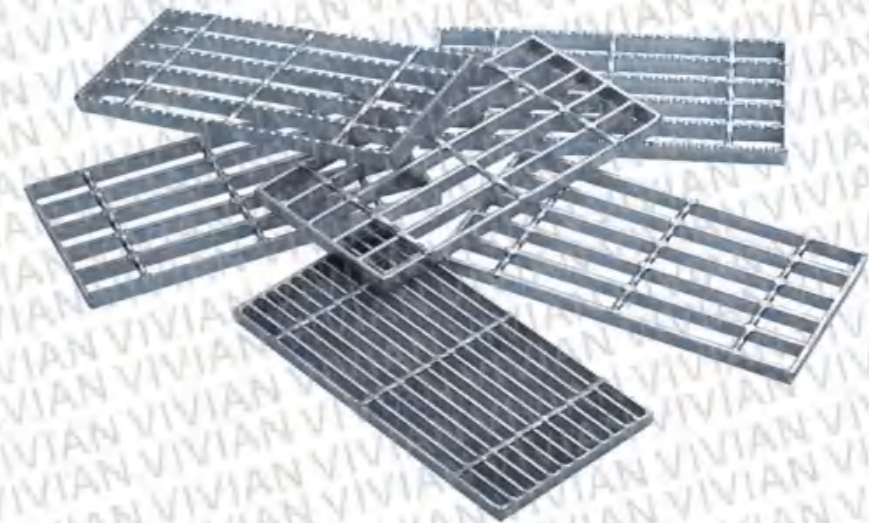

V-482



V-483



V-484

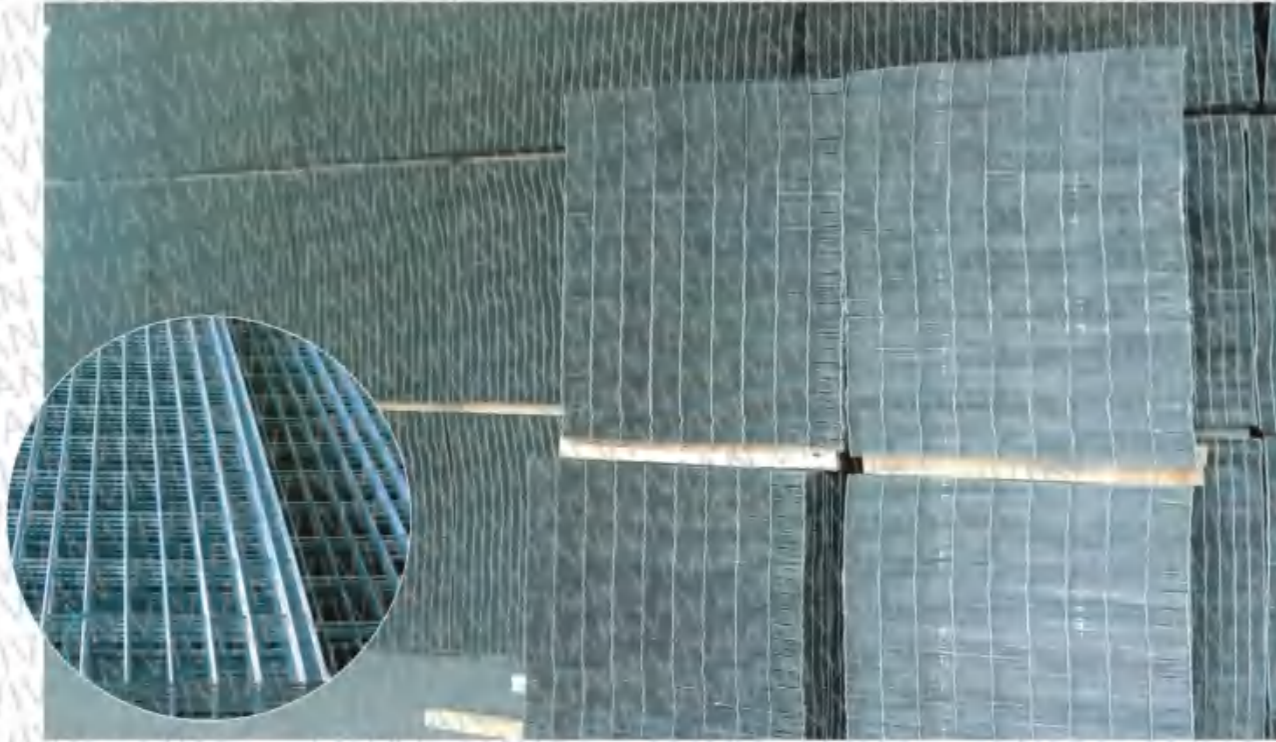

V-485



V-486



V-487



V-488



V-489

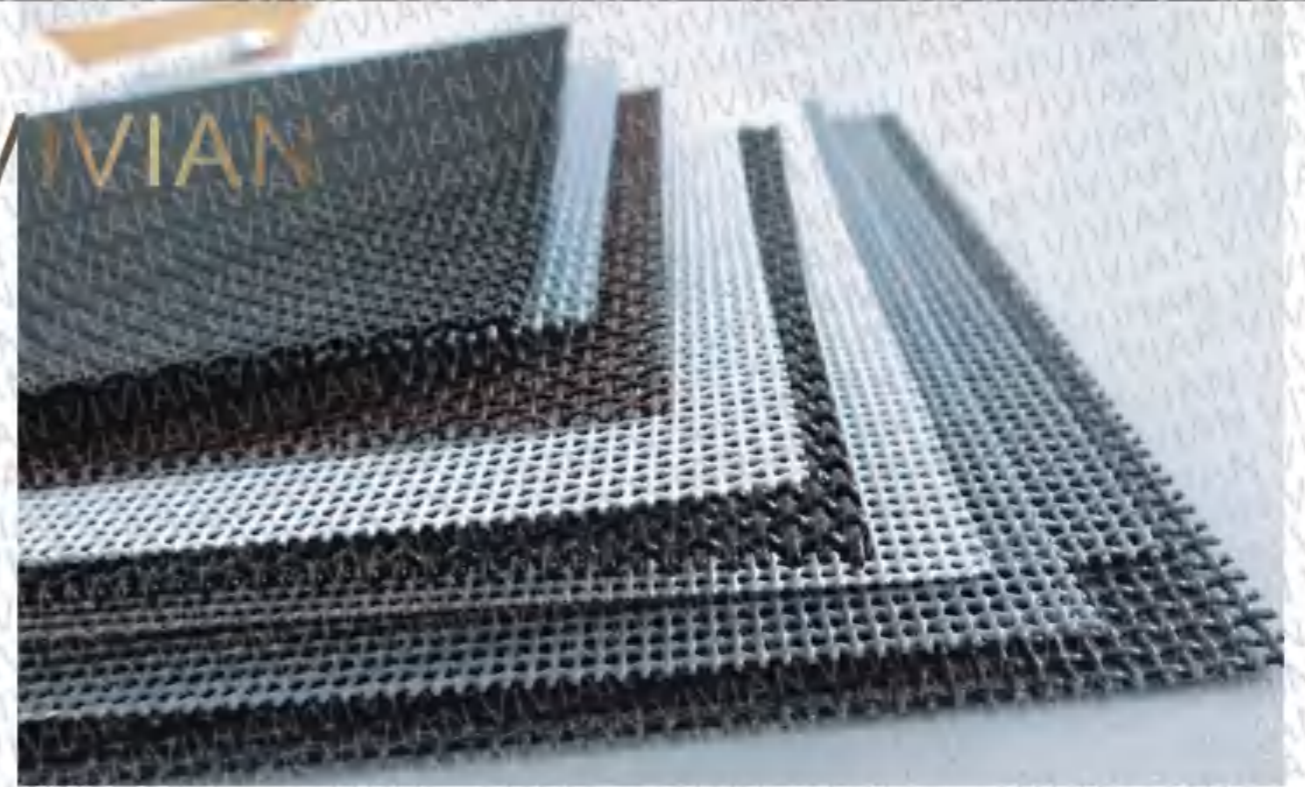

V-490



V-491



V-492

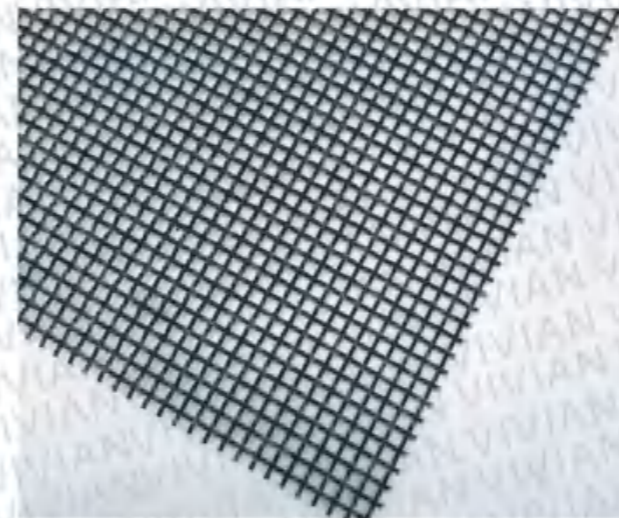

V-493



V-494



V-495



V-496



V-497



V-498



V-499



V-500



V-501



V-502



V-503



V-504



V-505



V-506



V-507



V-508



V-509



V-510



V-511



V-512



V-513



V-514



V-515



V-516



V-517



V-518



V-519



V-520



V-521

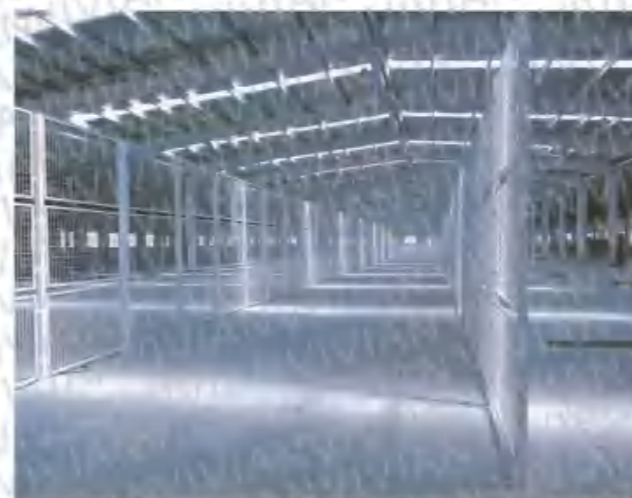

V-522



V-523

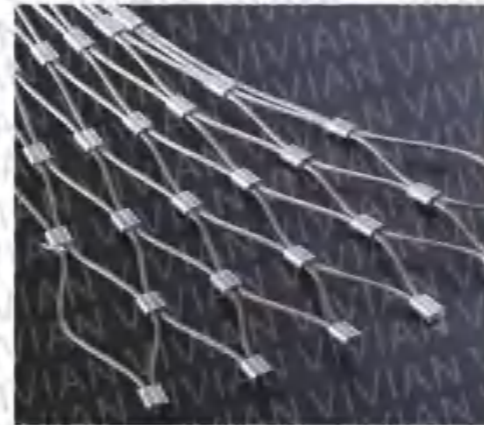

V-527



V-528



V-524



V-529

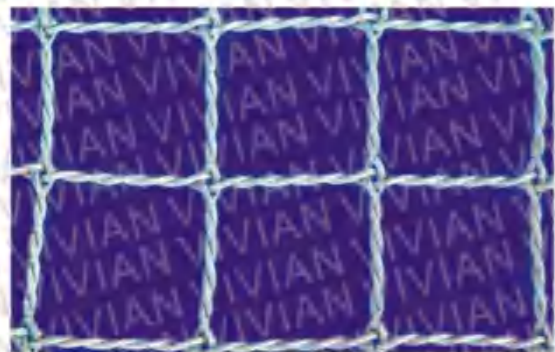

V-525



V-526



V-530

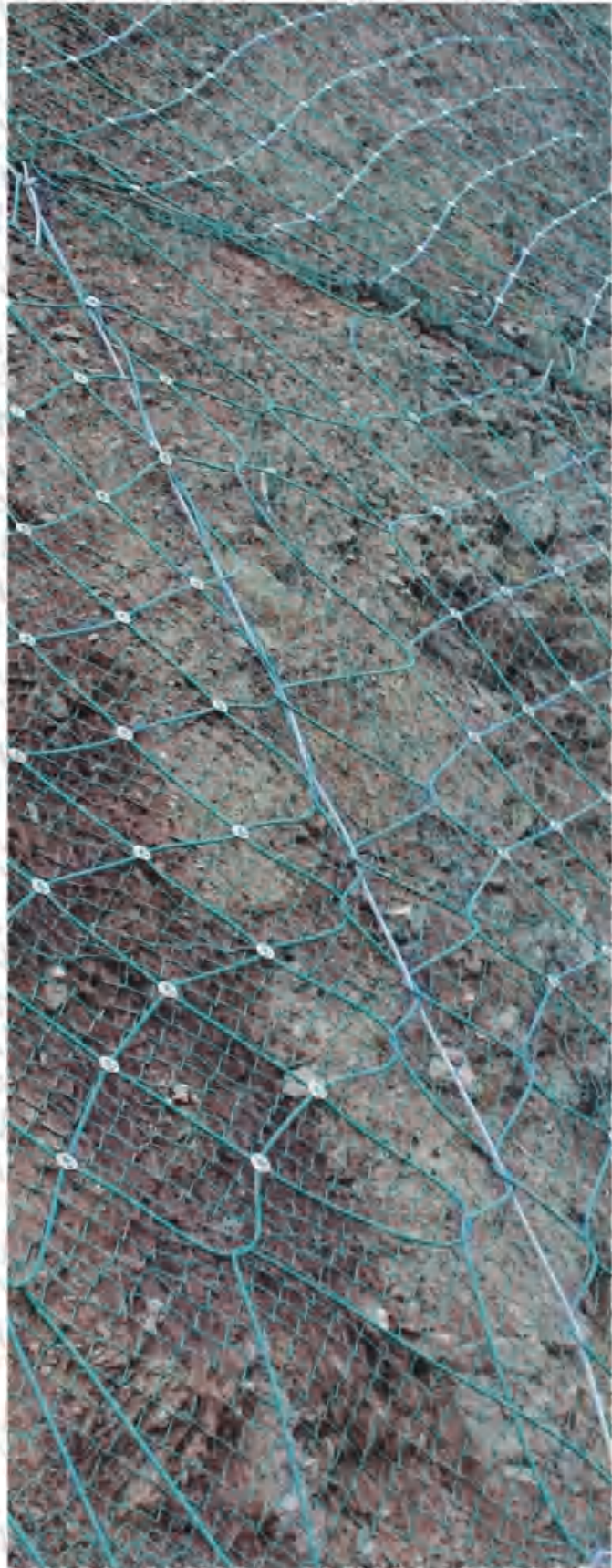

V-531



V-532



V-533



V-534



V-535



V-536



V-537



V-538



V-539



V-540



V-541

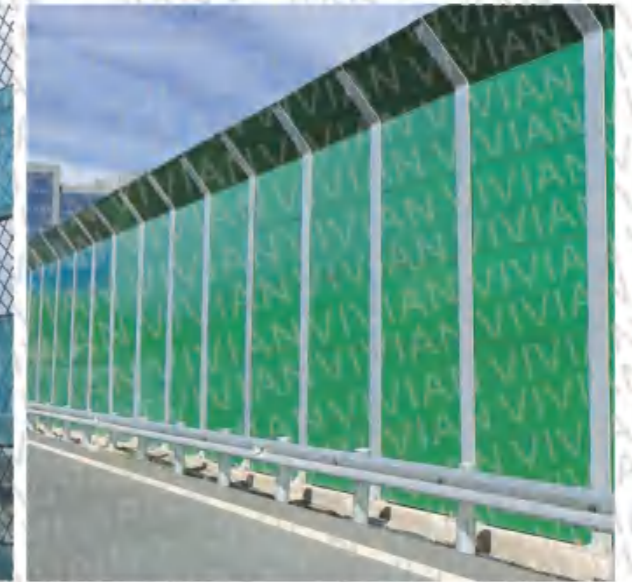

V-542

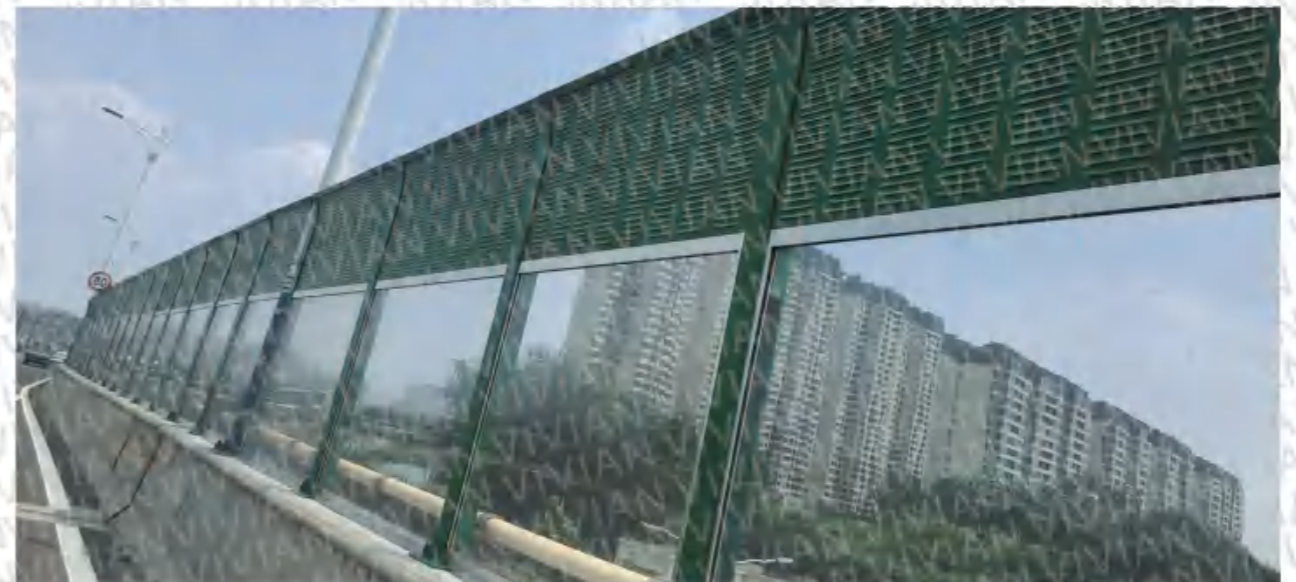

V-543



V-544



V-545



V-546



V-547



V-548



V-549

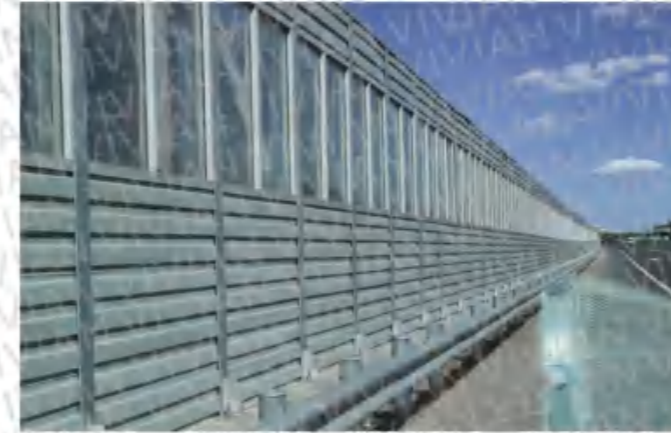

V-550



V-551



V-552

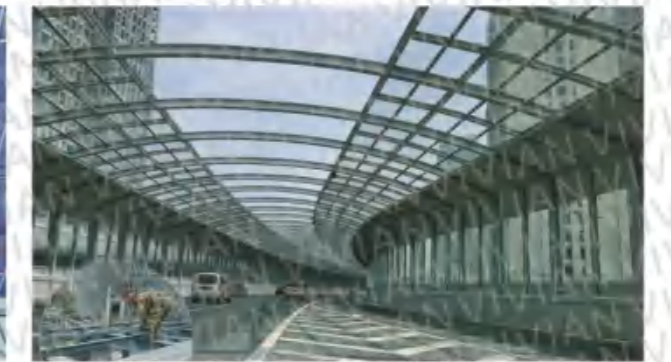

V-553

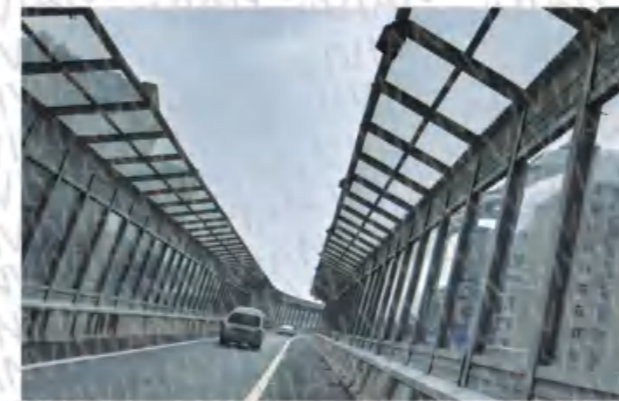

V-554



V-555



V-556



V-557

VIVIAN®



V-558

VIVIAN®



V-559

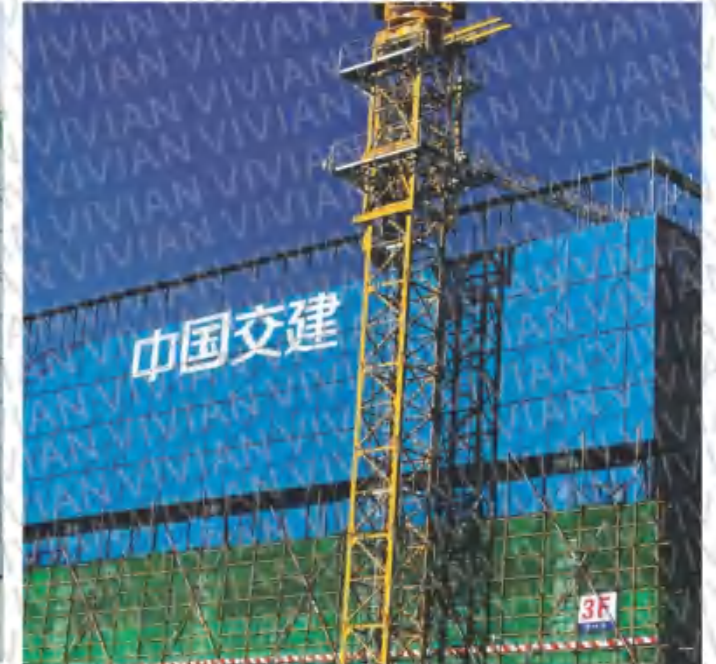

V-560

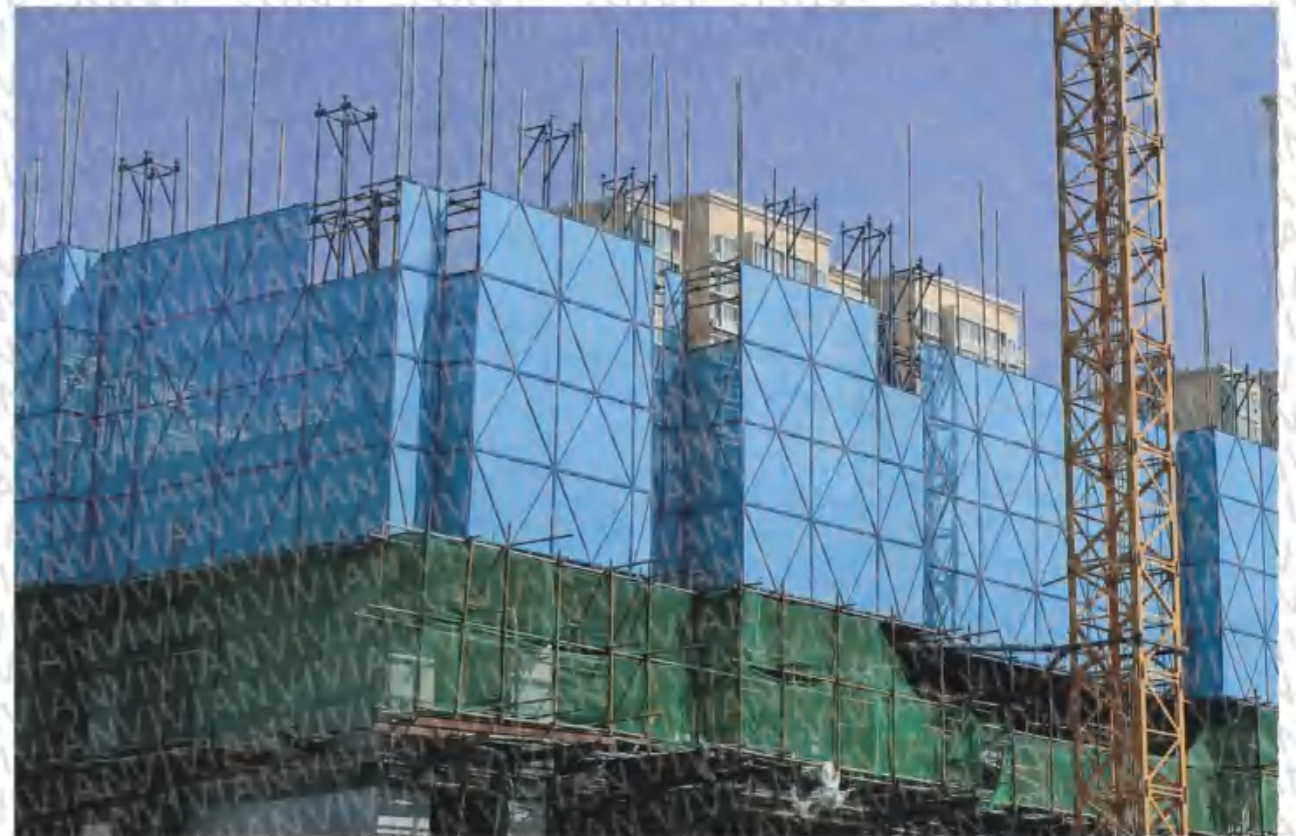

V-561

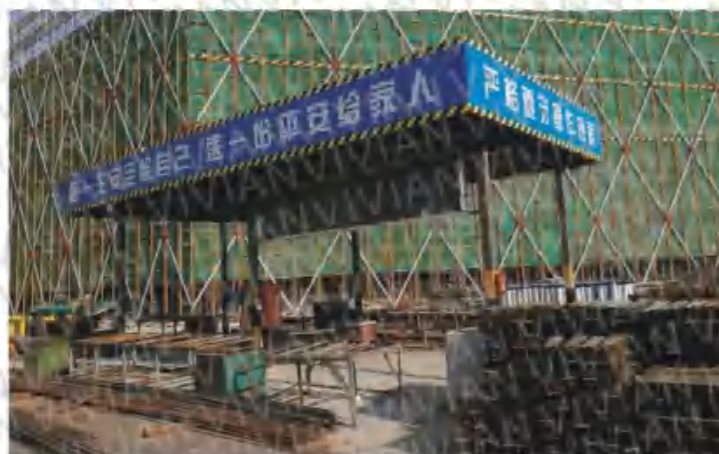

V-562

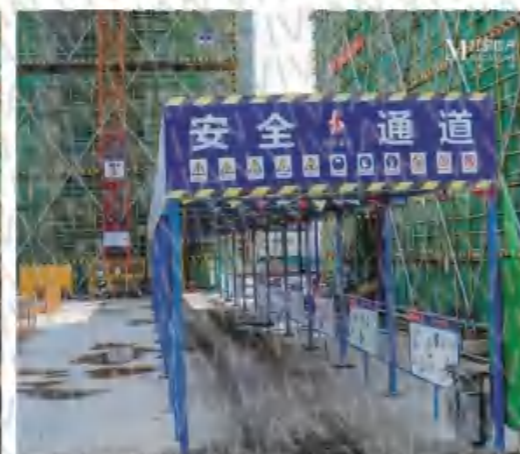

V-563



V-564



V-565



V-566



V-567



V-568



V-569



V-570



V-571



V-572



V-573



V-574



V-575



V-576



V-577



V-578



V-579



V-580



V-581



V-582



V-583



V-584



V-585



V-586

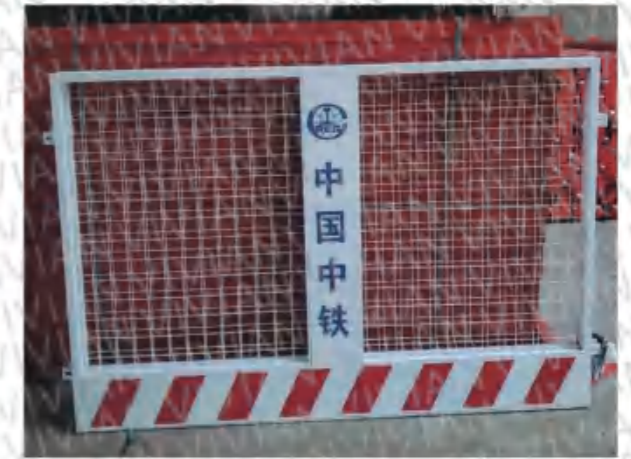

V-587



V-588



V-589



V-590



V-591



V-592



V-593



V-594



V-595



V-596



V-597



V-598



V-599

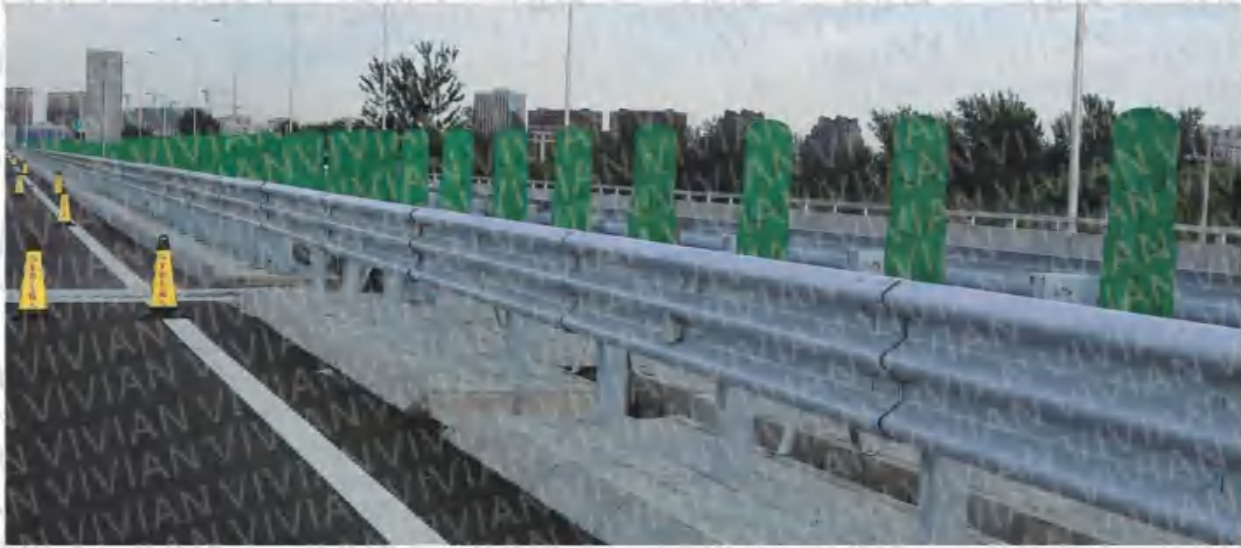

V-600



V-601



V-602



V-603



V-604



V-605



V-606



V-607



V-608



V-609



V-610



V-611



V-612



V-613



V-614



V-615



V-616

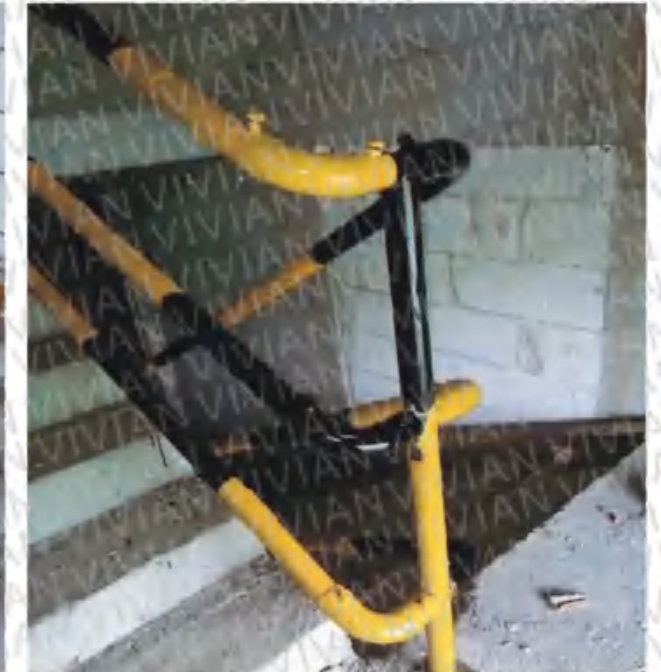

V-617



V-618



V-619



V-620



V-621



V-622



V-623

